BuzziSpace

2020 - 2021

NO BOUNDARIES



www.buzzi.space

CONTENT

004

004 - 007

008 - 011

012 - 021

022 - 025

027

028 - 157

158 - 227

228 - 271

272 - 319

320 - 327

328 - 391

394

397

STORIES

About BuzzSpace

Local Manufacturing

Meet our Designers

Silence is Not a Luxury

PRODUCT CATEGORIES

Acoustic Solutions

Acoustic Furniture

Furniture

Lighting

Outdoor

Materials

INDEX

CONTACT

A modern office lounge area with large windows, orange armchairs, and a table with stools. The space is bright and airy, with natural light streaming in from the windows. The furniture is contemporary and functional, designed for comfort and collaboration. The overall aesthetic is clean and professional, reflecting BuzziSpace's commitment to creating happy and healthy workspaces.

BuzziSpace

— We care about happy and healthy spaces

BuzziSpace creates solutions for happy and healthy workspaces around the world since 2007. Driven by an unbounded passion for solving modern workspace design challenges, we continuously reimagine furniture, lighting and acoustic office solutions. Our in-house studio collaborates with talented designers to provide new ways of working and living—comfortably, collaboratively and sustainably.

Improving the world through design is what drives us every day. This is reflected in numerous design awards and partnerships with well-known designers. With showrooms in Antwerp, New York and Chicago, and our own production site in Bladel (NL), we have firmly established ourselves as a global player, creating happy and healthy workspaces.

Our journey

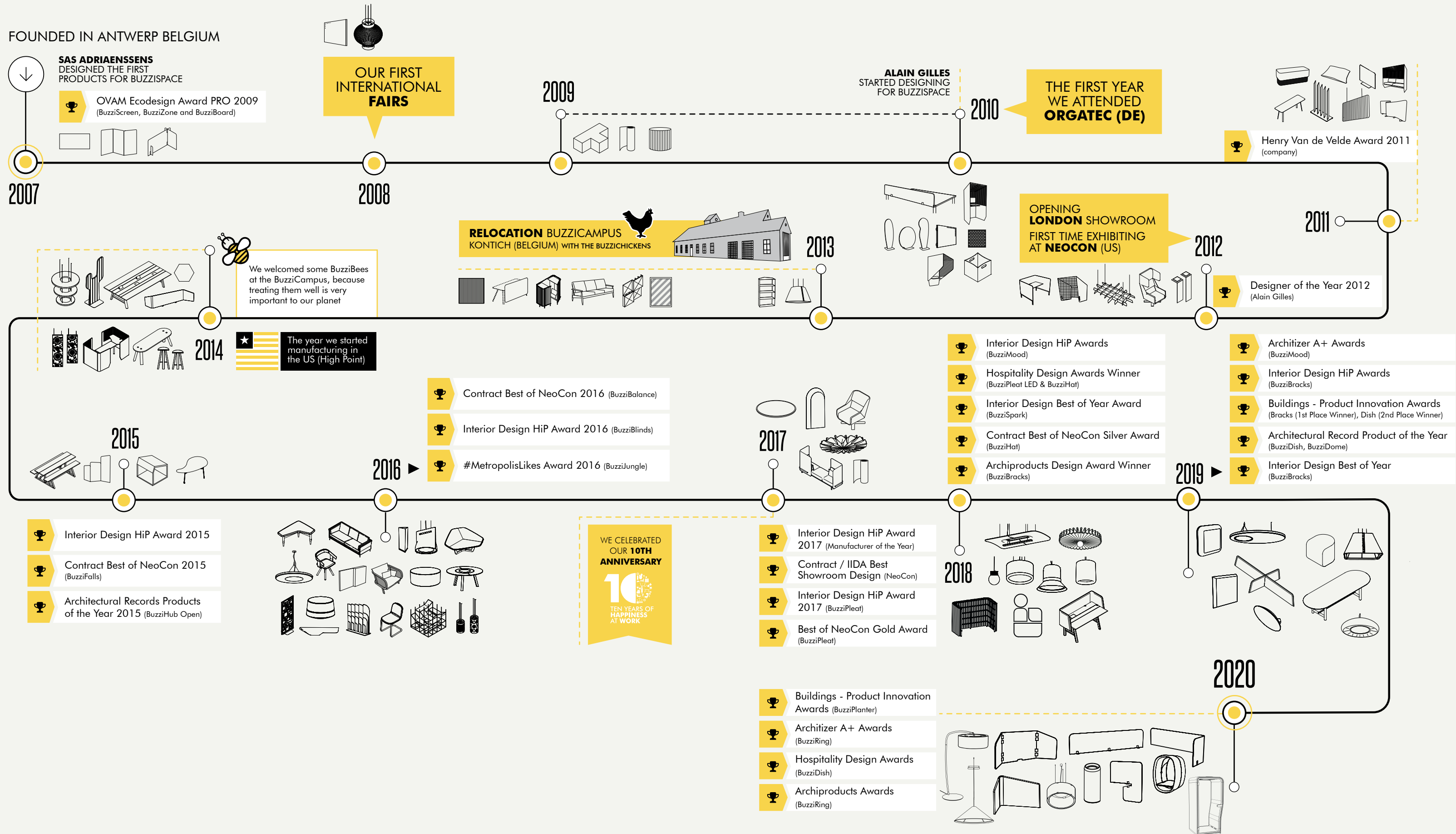

Local Manufacturing

At heart, we're all makers. We're born that way. Each one of us possesses the skills to create things that will amaze and surprise others, even ourselves. It happens daily at our local manufacturing facility in Bladel (NL) fueled by a shared desire to make durable and high-quality furnishings, both facilities bring out that extra sparkle in every BuzziSpace product that sets the brand apart from the competition.



Local Manufacturing in Bladel

Furniture-making is a tradition that goes back many years in Bladel. The unique characteristic is the ability to create quality products of the highest standards. In fact, the rich legacy of manufacturing furniture in both areas is a major reason why BuzziSpace chose Bladel for its manufacturing location.

Just across the border of Belgium in the Netherlands, you will find our manufacturing facility in Bladel. From the outside, it might look like any other production facility, but on the inside, it is anything but. Welcome to a world of imagination and innovation, a world where ideas are turned into reality - the world of BuzziSpace.

The facility in Bladel houses more than 80 employees across several departments, with more than 100 years of combined experience in foam cutting, upholstery and stitching. A handful of its current workforce was brought on from the last company to occupy the space, a manufacturer of caravan cushions, consequently bringing with them a strong level of expertise in upholstery and foam-work, which has been key to creating several BuzziSpace products.

Despite having an extensive skillset, employees do sometimes face challenges. The truth is, the process of making caravan cushions differs greatly from that of making a BuzziSpace product - the work is more rigorous and complex, and requires a much keener eye for detail.



For example, making a product like BuzziCube 3D involves a particularly complex lamination process. Expertise is required to find the right balance between pressure, temperature and glue, to seamlessly fasten fabric to the 3D cut foam. Every time a new fabric is introduced, our production team has to reevaluate the formula from scratch, so the team is constantly innovating to meet new challenges.

At BuzziSpace, craftsmanship is crucial to guarantee high-quality finished products. In several departments, much of the work is still done by hand, requiring special techniques to achieve the desired result. For instance, lacing and upholstery are some of the departments in which the work necessitates a steady hand and eye for detail. Here, the work is both an art and a skill.

Every year, thousands of meters of fabrics and cubic meters of foam are used to produce BuzziSpace solutions. It's inevitable to avoid any waste materials. With sustainability being one of BuzziSpace's founding pillars, both facilities have implemented recycle management of core materials such as foam, cardboard and fabric.

In Bladel, for instance, foam recycling has proven to be a great success in resourcing old materials and eliminating excess waste.

At BuzziSpace, every employee at the manufacturing facility shared a passion for a shared passion for making products that will solve the modern design challenges of today—and beyond.

“ Lacing and upholstery are some of the departments in which the work necessitates a steady hand and eye for detail. Here, the work is both an art and a skill.



Meet our Designers

BuzziSpace has always given opportunities to both upcoming and established designers to develop products and ideas that match the DNA of BuzziSpace. These designs are often ahead of their time and each tells a unique story. They do not only look good but they also meet a particular need.

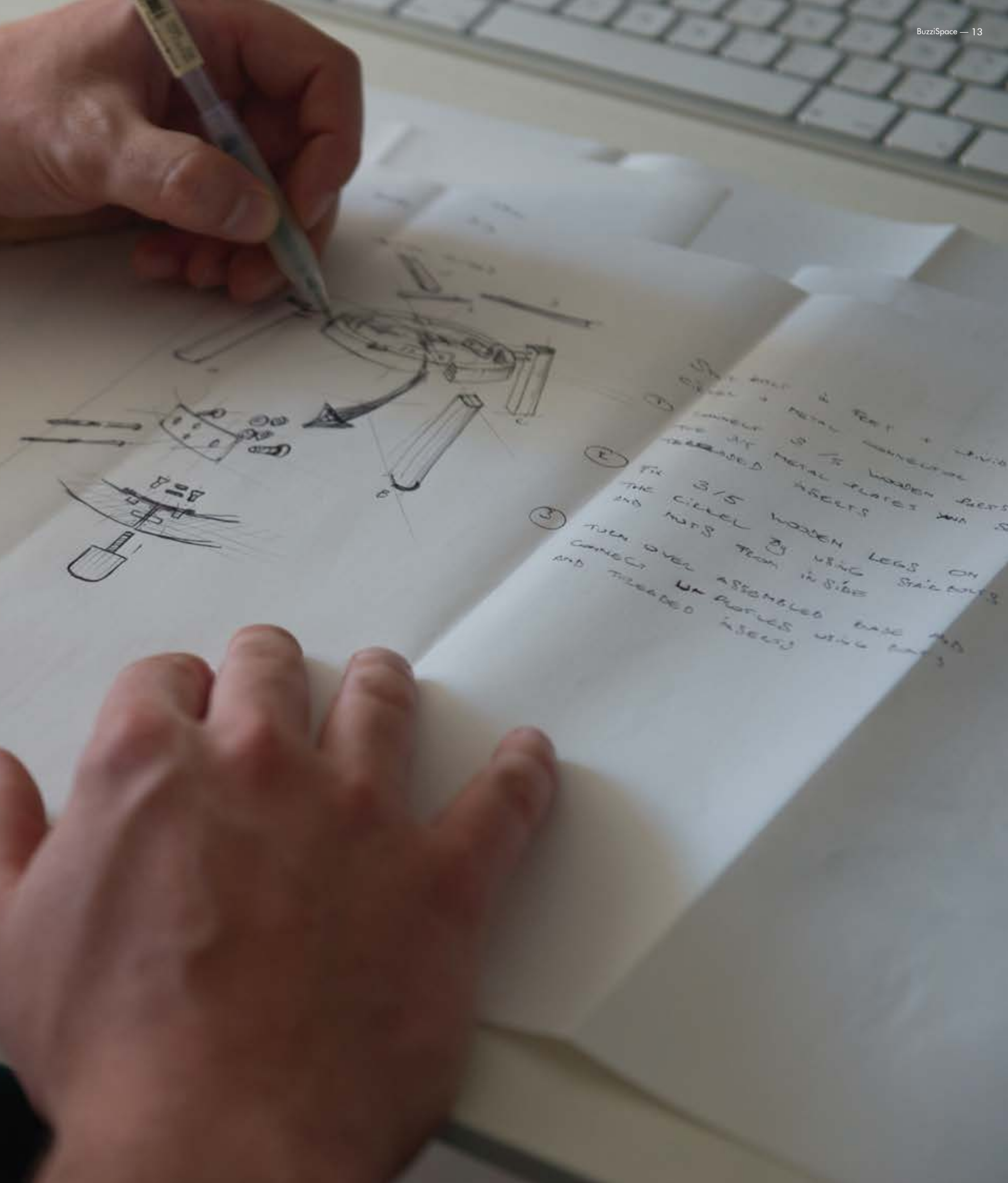

①
②
③
④
⑤
⑥
⑦
⑧
⑨
⑩
⑪
⑫
⑬
⑭
⑮
⑯
⑰
⑱
⑲
⑳
㉑
㉒
㉓
㉔
㉕
㉖
㉗
㉘
㉙
㉚
㉛
㉜
㉝
㉞
㉟
㊱
㊲
㊳
㊴
㊵
㊶
㊷
㊸
㊹
㊺
㊻
㊼
㊽
㊾
㊿



- ### AWARDS
- 🏆 Design Brussels Awards 2007 (Best Belgian Product)
 - 🏆 L'esprit Marie Claire Maison 2008 (Maison & Objet Paris)
 - 🏆 Design at Work 2008 (Interieur Foundation)
 - 🏆 Henry Van de Velde Label 2009 (BuzziBoard)
 - 🏆 OVAM Ecodesign Award PRO 2009 (BuzziScreen, BuzziZone and BuzziBoard)
 - 🏆 Contract Best of NeoCon 2015 (BuzziFalls - Gold Award Winner)
 - 🏆 Interior Design HiP Award 2015 (BuzziFalls - Winner)
 - 🏆 Architizer A+ Award 2016 (BuzziFalls - Popular Choice)

Sas Adriaenssens



I don't design with the 'new way of working' in mind, because I believe that people work and live how they want to. It's my role as a designer to listen to their needs and try to give them a personalized solution.

Sas Adriaenssens obtained a master's degree in graphic design and illustration and after several years in marketing, naturally moved into the world of interior and product design. After many years of experience in companies of all shapes and sizes, she went freelance in order to create her own cocktail of creativity and practical organisation. She prefers to describe herself as a 'creative problem-solver with a compulsive aesthetic sense'.

Sas designed the very first products of BuzziSpace, which were made out of ecofelt, a hundred percent recycled material made of old plastic bottles. They were an instant hit and won several awards. BuzziSpace was catapulted into the spotlight and rapidly expanded its range keeping its original philosophy in mind: ecology, flexibility and acoustics.

BUZZISPACE PRODUCTS

2007 BuzziBoard BuzziScreen BuzziZone	2008 BuzziBack BuzziLight	2009 BuzziSkin	2010 BuzziGrip BuzziTile	2011 BuzziTwist BuzziSeat	2013 BuzziBrickBack BuzziRug	2014 BuzziCactus BuzziFalls	2015 BuzziScreen Mix	2016 BuzziSkin Printed BuzziLight Mono BuzziLight Alhambra BuzziLight Royal BuzziFalls Standing BuzziChandelier
---	--	--------------------------	---------------------------------------	--	---	--	--------------------------------	--

Alain Gilles



Design is in the details.



After studying Political Sciences and Marketing Management, Alain Gilles went on to work in the international financial world for five years, but he decided to follow his passion. Thanks to the moral support of his wife, he went back to study Industrial Design in France. He opened his own studio in 2007 in order to pursue his dreams and develop his personal approach to product design, furniture design, art direction and scenography. In 2012, he was named "Designer of the Year" by the prestigious Interieur Kortrijk Foundation in Belgium.

Alain Gilles started designing for BuzziSpace in 2009 and developed the BuzziHood, an acoustic cocoon you can hang on the wall and a fun reminder of the classic vintage phone booths. Alain's experience with working in a corporate environment for 5 years also helped him understand the needs of open-plan offices, which he incorporated in new product ideas for BuzziSpace. Each of them are groundbreaking products that fit perfectly into the philosophy of BuzziSpace.

AWARDS

- 🏆 Henry Van de Velde Label 2011 (BuzziBooth)
- 🏆 Designer of the Year 2012
- 🏆 Interior Design HiP Awards 2014 (BuzziPicNic - Winner) • (BuzziVille - Honoree)
- 🏆 Contract Best of NeoCon 2014 (BuzziPicNic - Editors' Choice)
- 🏆 Interior Design Best of Year Award 2014 (BuzziVille - Best Furniture)
- 🏆 Interior Innovation Award 2014 (BuzziVille)
- 🏆 Architectural Products 2014 (BuzziVille - Product Innovation Award)
- 🏆 ADEX Silver Award for Design Excellence, 2014 (USA) (BuzziHive)
- 🏆 Good Design Award, 2014 (USA) (BuzziPicNic)
- 🏆 IMM Innovation Award 2014 (Cologne, DE) (BuzziPicNic)
- 🏆 Architizer A+ Award 2015 (BuzziPicNic - Jury Winner)
- 🏆 Interior Innovation Award 2015 (BuzziPicNic)
- 🏆 iF Design Award 2015 (BuzziPicNic)
- 🏆 Azure AZ Award 2015 (BuzziPicNic - Award of Merit)
- 🏆 Architectural Record Products of the Year 2015 (BuzzHub Open - Best in Category)
- 🏆 Interior Design HiP Award 2016 in category 'Accessories' (BuzziBlinds - Winner)
- 🏆 Interior Design Best of Year Award 2016 (BuzziFloat - Best Seating: Contract/Conference)
- 🏆 Wallpaper Design Award 2017 (BuzziBlinds)
- 🏆 Architect's Newspaper 2017 Best of Products Award in category 'Commercial Interior Furniture' (BuzziFloat)
- 🏆 Design Week Awards 2017 in category 'Furniture Design' (BuzziFloat - Honoree)
- 🏆 Contract Best of NeoCon 2017 in category 'Lighting' (BuzziHat - Silver Award Winner)
- 🏆 Hospitality Design Awards 2018 in category 'Lighting' (BuzziHat - Winner)
- 🏆 Interior Design HiP Awards 2018 in category 'Lighting' (BuzziHat - Winner)
- 🏆 Buildings' Product Innovations 2018 in category 'Seating' (BuzziSpark - Honoree)
- 🏆 Interior Design HiP Awards 2018 in category 'High Back Seating' (BuzziSpark - Honoree)
- 🏆 Buildings' Product Innovations 2018 in category 'Lighting' (BuzziZepp LED - Honoree)
- 🏆 Archiproducts Design Awards 2018 in category 'Office' (BuzziBracks - Winner)

BUZZISPACE PRODUCTS

2010 BuzziHood BuzziBooth	2011 BuzziBlinds Classic BuzziHub BuzziHub Table	2012 BuzziGrid BuzziBooth Targa BuzziCockpit BuzziTemp	2013 BuzziHive	2014 BuzziVille BuzziMilk BuzziMilk Table BuzziPicNic BuzziDesk FlipFlop	2016 BuzziBlinds BuzziPicNic Round BuzziFloat	2017 BuzziMirage	2018 BuzziHat BuzziSpark BuzziZepp BuzziZepp LED BuzziBracks	2019 BuzziTable
--	--	---	--------------------------	--	---	----------------------------	--	---------------------------

13&9 Design

“ We encourage interdisciplinarity in every design project. Our different backgrounds give us the flexibility to use unconventional skills in developing new products.

Austrian product design firm 13&9 was founded in 2013 in Graz and is based on the partnership between architect and CEO of INNOCAD Architecture, Martin Lesjak (Contract magazine’s Designer of the Year) and designer Anastasia Su (who also studied medicine). 13&9 is a design studio for international companies and also has its own label that designs, produces and sells their own products. The interdisciplinary team’s successful cooperation with specialist partners has led to achievements in furniture, lighting, floor coverings, fashion, accessories and art objects, as well as exhibition and sound design projects. 13&9 collaborated with BuzziSpace for the first time in 2016 and created the BuzziBalance and BuzziBalance Board. Two pieces that encourage movement and energy—creating a hub of social activity in the office space.



BUZZISPACE PRODUCTS

- 2016 BuzziBalance
- 2017 BuzziPleat
- 2018 BuzziPleat LED

AWARDS

- 🏆 Interior Design HiP Award 2016 in category ‘Well-being’ (BuzziBalance - Honoree)
- 🏆 Contract Best of NeoCon 2016 in category ‘Office Accessories’ (BuzziBalance - Gold Award Winner)
- 🏆 Good Design Award 2016 (BuzziBalance)
- 🏆 Active Office Award 2017 (BuzziBalance)
- 🏆 Architectural Record’s Record Products 2017 in category ‘Best Furnishings’ (BuzziPleat)
- 🏆 Buildings’ Product Innovations 2017 in category ‘Merit Award: Acoustics’ (BuzziPleat)
- 🏆 Contract Best of NeoCon 2017 in category ‘Acoustic Panels & Solutions’ (BuzziPleat - Gold Award Winner)
- 🏆 Interior Design Best of Year Award 2017 in category ‘Acoustic Furnishings’ (BuzziPleat)
- 🏆 Interior Design HiP Awards 2017 in category ‘Accessories’ (BuzziPleat)
- 🏆 Archiproducts Design Selection 2018 (BuzziPleat LED)
- 🏆 Hospitality Design Awards 2018 in category ‘Other’ (BuzziPleat LED - Winner)



Jeffrey Huyghe

With a background in industrial product design, mechanical engineering, and lighting, Belgian designer Jeffrey Huyghe has a broad understanding of different design disciplines. Architectural lighting was his first love and has only grown bigger throughout the years. This, however, hasn’t stopped the young talent from extending his portfolio to include other designs, for instance, acoustic solutions. Lighting or non-lighting, there’s a common theme, a signature, that unites Jeffrey’s portfolio. Everything rotates. Everything is built to move and to surprise!

BUZZISPACE PRODUCTS

- 2019 BuzziDish

“ Everything I create has a spark of magic. Each design holds a moment of surprise while maintaining its original purpose.

Jonas Van Put

Jonas Van Put is a young Belgian interior architect and furniture designer. He creates monumental steel constructions, furniture and art installations that question and improve social interaction. He is intrigued by nature, landscapes and everything that derives from this. The underlying processes of nature as well as artificial circumstances on different scales fascinate him. The launch of the BuzziJungle introduced the design world to young Belgian talent Jonas Van Put. It was Van Put’s first project with an international manufacturer.

BUZZISPACE PRODUCTS

- 2016 BuzziJungle

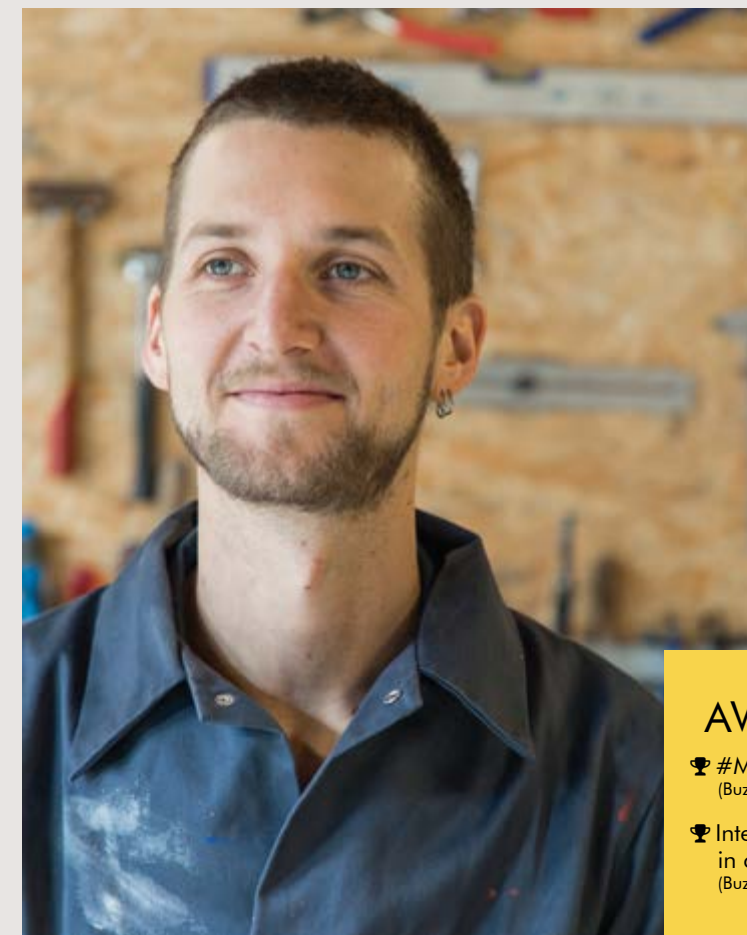

“ In every design, I pay attention to the relationship with its public, and question social interactions among people.

AWARDS

- 🏆 #MetropolisLikes Award 2016 (BuzziJungle)
- 🏆 Interior Design HiP Award 2016 in category ‘Office Furniture’ (BuzziJungle - Honoree)



Chris Hardy

Chris Hardy is an American industrial designer based in Atlanta. Born in 1984, he pursued an education in design, receiving a BFA from the College for Creative Studies in Detroit and a Masters of Design from the School of Design at the Hong Kong Polytechnic University. After returning to the United States in 2009, he began his career as a freelance designer collaborating with companies for both industrial and graphic design. His clients include interior design firms, retail stores, furniture and lighting manufacturers, and design publications. For the expansion of BuzziSpace’s range of acoustical lighting solutions, Chris Hardy created a distinctive new pendant shape, named BuzziBell, that won an Interior Design HiP Award Honoree at NeoCon 2016.

“ I aim to develop pieces that can be connected with on an emotional level. My work is inspired by the challenge of personalization in the modern world and the increasing desire we have to own objects that match our own styles and philosophies.

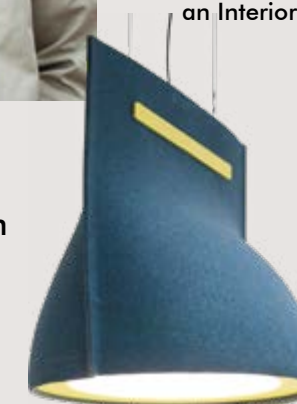

BUZZISPACE PRODUCTS

- 2016 BuzziBell



Gerd Couckhuyt

Belgian designer Gerd Couckhuyt opened his own design studio 'Bhoom' in 2012 and was a late bloomer in the design world. At a very young age, he began his career at Bekaert Engineering as a mechanic and later as an electrician. At the age of 18, his interest for interior design was stimulated by a friend who painted. Later he obtained several degrees in art, interior design, light consultancy and sculpture art. The combination of his technical background and his feeling for creation and art makes him a more complete designer with an eye for the visual and the technical aspects. His inspiration comes from daily visual and emotional impulses. Designing objects and interiors is not an assignment for Gerd, but a distillation and fine-tuning of ideas already present in his mind. He now works for several international brands, such as Modular, Wildspirit, Manutti, etc. With his design 'Elements' for Manutti he won the prestigious Red Dot Award in 2014.

“

All our furniture designs share a certain relationship: there is always a link, a kind of visual logic and a magical interplay of relationships. Call it unity in diversity if you will. Conspicuous details give all our designs a distinct identity and catch everyone's eye.

AWARDS

🏆 Interior Design HiP Awards 2017 in category 'Hospitality: Seating' (BuzziBounce - Honoree)

BUZZISPACE PRODUCTS

2016 BuzziBounce
BuzziPlank

Wiebe Boonstra & Marc van Nederpelt

“

You always remember the man with the scar.

DUM OFFICE is a Dutch design studio founded by designers Wiebe Boonstra and Marc van Nederpelt in the late nineties. The main objective of DUM OFFICE is to provide spaces with distinctive items all with a recognizable DUM signature: edgy, clean, playful, colorful and subtle. BuzziCane fits perfectly in their playful aesthetic signature and in our BuzziSpace DNA. The informal design of the BuzziCane welcomes guests with its friendly feel.



AWARDS

🏆 #MetropolisLikes Best of NeoCon 2017 (BuzziCane)

🏆 Architectural Record's Record Products 2017 in category 'Best Lighting Products' (BuzziCane)

BUZZISPACE PRODUCTS

2016 BuzziCane

Cory Grosser

“

As a designer, empathy is crucial. It's about understanding and transforming how people feel in a space. Of course, functionality is important too, but nothing beats putting a smile on people's faces.

Cory Grosser + Associates ("CG+A") is a multi-disciplinary, boutique design agency that implements beautiful design for the benefit of commerce and culture. Founded in 2002 by American designer, Cory Grosser, CG+A's approach drives creative strategies for brands and engaging narratives for people. The Pasadena-based studio has collaborated with many top American and international brands on projects in the fields of: architectural design, furniture and product design, design strategy and creative direction.



AWARDS

🏆 Interior Design HiP Awards 2018 in category 'Biophilic Acoustics' (BuzziMood - Winner)

BUZZISPACE PRODUCTS

2018 BuzziMood

“

Our biggest challenge is to constantly innovate and search for an innovative and original approach which we can be proud of.

COUVREUR.DEVOS

Bram Couvreur & Björn De Vos are a Belgian design duo who dare to reach beyond the borders of the everyday. COUVREUR.DEVOS is part of Maister, a creative agency, and focuses on interior design and product development. Whether it's a question of lighting, champagne bottles or designing an interior: they make sure form and function are in harmony every single time. In 2012, they designed BuzziWings for BuzziSpace, an inventive partition that ensures optimum acoustics and a subtle lighting of the room thanks to the integrated, indirect light source.



BUZZISPACE PRODUCTS

2012 BuzziWings

Axel Enthoven

Axel Enthoven (1947) a big name in design land. With his design bureau, Yellow Window (formerly known as Enthoven Associates Design Consultants), he not only designs furniture but also buses, trams, trains or even medical equipment. This Antwerp-based design bureau has already made 1,900 products, and is active worldwide in product development, design consultancy and innovation research. The team has won several awards, including various Red Dot Design Awards and IF Design Awards. For his pioneering work in the design sector, Axel Enthoven received the Henry Van de Velde Award in 2004. For BuzziSpace he designed the BuzziMe in 2012. The ideal lounge chair to get away from it all.



The big difference between designing today and in the past is that designing now has become teamwork, while it used to be a one-man business. Today there are so many different elements associated with our profession that are very important like for example marketing.

BUZZISPACE PRODUCTS

2012

BuzziMe

2018

BuzziMe Low

Jean-Pierre Galeyn



We design from the bottom up, creating unique, innovative products appreciated by consumers, concerned by better quality and long-term use.

Jean Pierre Galeyn owns a craft workshop called Tradewinds, where outdoor and garden products are created, assembled and distributed. The art of outdoor living is their main concern, so they reshape widely used and distributed products to restore their authentic purpose and make them lasting, user-friendly and pleasant to the eye. They seek for the perfect blend between authentic craftsmanship and new technology to achieve unique objects.

BUZZISPACE PRODUCTS

2015

BuzziShed



Stal Collectief

Stal Collectief is a collaboration between four young furniture designers who studied in Mechelen (Belgium): Len de Paepe, Bob Segers, Tim Vranken and Jonas Blondeel. This collective, which occurred through common interest and friendship, wants to create timeless and honest pieces of furniture and lighting objects. New ideas are conceived, prototyped and sometimes even developed under one roof. The BuzziShade, which provides light and absorbs sound at the same time, is the culmination of an artistic collaboration between BuzziSpace and the four young Belgian furniture designers of Stal Collectief.

BUZZISPACE PRODUCTS

2013

BuzziShade

Anthony Duffeleer



Designing is the outcome of a process where the role of the designer is seriously relative. The material, the production process and other parameters control the direction and form of our designs.

The Flemish architect Anthony Duffeleer heads the Antwerp-based agency Frap together with architect Freia Rombouts. The duo is specialized in product design and architecture. In addition to this, Duffeleer is the initiator of Xala, a collection of must-haves for house and garden. As a designer he is particularly interested in the quest for the right production method. In 2010, he designed a funky room divider for BuzziSpace, named BuzziPlant.

BUZZISPACE PRODUCTS

2010

BuzziPlant



Silence is Not a Luxury

From the very beginning, acoustics have been a driving force when developing or considering new products. A well-balanced room with a perfect acoustical level is a key factor to the performance and well-being of workers all over the world and therefore our logical main concern. For BuzziSpace, acoustics is more than just a generic word. It's our way of caring for workers and contributing to a pleasant working environment by balancing any given space with the recommended reverberation time and enhancing the speech intelligibility.



UNDERSTANDING ACOUSTICS

Sound consists of pressure waves running through the air. It can be described as energy, created by vibrations, transmitted through the air or any other medium. The inner ear converts those vibrations into electric signals, which are sent to our brain, where they will be processed and perceived as the actual sound coming in. Consequently, sounds are perceived differently depending on the frequency, intensity (decibel), and reverberation time in a room.

Frequency

The wavelength determines the sound frequency. It is measured as the number of repetitive vibrations per cycle per second and is expressed in Hertz. The audible range of sound is between 20 to 20 000 Hz. The higher the frequency, the higher the tone.

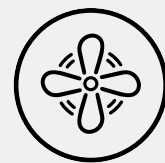
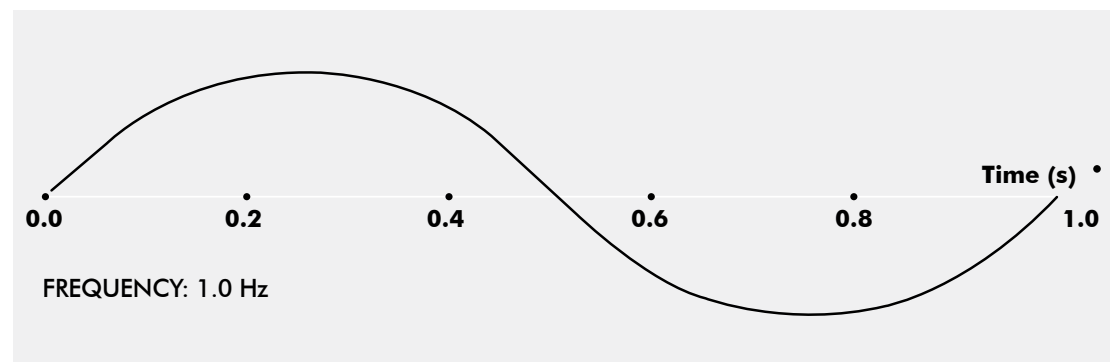

Low tone

Long wave - Low frequency (50 - 250 Hz)

E.G. heating systems, ventilation, elevators, copy machines, server rooms

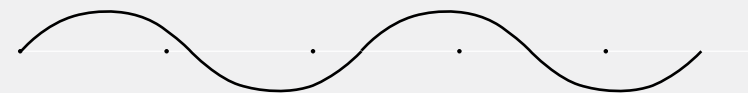

Mid tone

Mid length wave - Speech frequency (250 - 2500 Hz)

E.G. speech, vowels, consonants

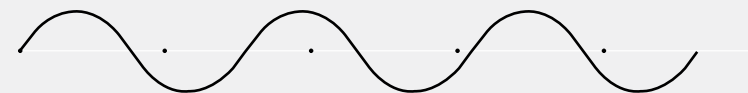

High tone

Short wave - High frequency (2500 - 12000 Hz)

E.G. ringtones, typing sounds, clicking sounds, kids

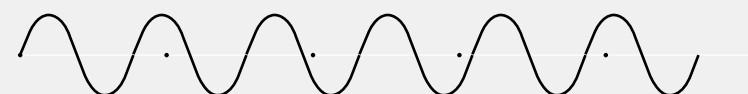

Acoustic Principles

To create a better acoustical environment and reduce reverberation time in a room, BuzziSpace products are developed to perform on one or more of the following acoustic principles.

Absorption

Sound waves are absorbed by any 'acoustically soft' material they encounter.

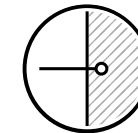

Sound is energy and in order to stop this energy from propagating, absorptive panels will be used to convert this energy into heat through friction. The absorption coefficient of a product will determine the level and quality of absorption. Absorption applies to fixed wall or ceiling elements.

Diffusion

Sound energy is spread evenly in a given space.

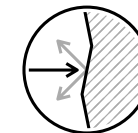

Wavelengths which cannot be absorbed through acoustic treatment will scatter evenly back into the room, ensuring a better spread while maintaining a live, vivid sound. This property can be obtained by alternating different depths of absorptive material and 3D shapes.

Attenuation

Reducing the sound transfer within a room.

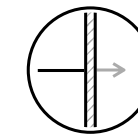

In order to reduce the sound transfer between different spaces, vertical elements will be applied to cut down sound energy. Those can come in different shapes such as sound blocks, vertical ceiling panels, room dividers and desk screens. Attenuation or sound dampening has a positive impact on speech intelligibility and clarity.

Reverberation time

Reverberation time is the time needed for an original sound source to decay 60 dB and is expressed in seconds. In order to generate excellent speech intelligibility and clarity, the reverberation time should be adjusted and balanced by means of absorptive material in function of the specific acoustical issues in a given space. The recommended reverberation time will always have to be adapted to the room volume and the type of activity.

RECOMMENDED REVERBERATION TIME:

- Office: 0.75s
- Meeting room: 0.60s
- Cafeteria: 1.00s
- Gymnasium: 1.50s
- Auditorium: 1.50s to 2.00s

For detailed acoustic reports, check the product pages on our website: www.buzzi.space



INDEX PRODUCT CATEGORIES

ACOUSTIC SOLUTIONS

BuzziBack	32
BuzziBlinds Classic	34
BuzziBlinds	37
BuzziBlox	41
BuzziBoard	47
BuzziBrickBack	49
Architectural	50
BuzziCactus	52
BuzziDesk	55
BuzziDesk Cross	59
BuzziDesk FlipFlop	60
BuzziDesk Split	63
BuzziDish	64
BuzziDonut	66
BuzziFalls	71
BuzziFalls Standing	75
BuzziFree	79
BuzziFrio	81
BuzziFrontDesk	82
BuzziGrid	85
BuzziGrip	86
BuzziKey Soft	89
BuzziLand	91
BuzziLoose	92
BuzziMood	94
BuzziPlant	97
BuzziPlanter	98
BuzziPleat	102
BuzziScreen	106
BuzziScreen Mix	108
BuzziShield Desk	111
BuzziShield Free	114
BuzziShield Hook	116
BuzziSkin	120
BuzziSkin Cuts	123
BuzziSkin Printed	124
BuzziTab Soft	126
BuzziTile Flat	128
BuzziTile 3D	130
BuzziTotem	135
BuzziTripl Desk	140
BuzziTripl Desk Split	142
BuzziTripl Home	144
BuzziTripl Wrap Desk	146
BuzziTwist	149
BuzziWings	150
BuzziWrap Desk	152
BuzziWrap FrontDesk	154
BuzziZepp	156

ACOUSTIC FURNITURE

BuzziBalance	162
BuzziBracks	167
BuzziBooth	173
BuzziCube Flat	176
BuzziCube 3D	178
BuzziDee	180
BuzziHive	185
BuzziHood	187
BuzziHub	189
BuzziHug	190
BuzziMe	193
BuzziNest	197
BuzziPouf	205
BuzziPuzzle	207
BuzziRing	208
BuzziSpark	210
BuzziSpot	217
BuzziTemp	219
BuzziVille	220

FURNITURE

BuzziBounce	230
BuzziBox	233
BuzziBox Travel	235
BuzziCane	236
BuzziFloat	239
BuzziHub Table	243
BuzziJungle	245
BuzziMilk	246
BuzziMilk Table	251
BuzziMirage	253
BuzziNordic ST100	254
BuzziNordic ST400	257
BuzziPicNic	258
BuzziPicNic Round	264
BuzziPlank	267
BuzziSuzzi	269
BuzziTable	270

LIGHTING

BuzziBell	274
BuzziChandelier	276
BuzziCone	278
BuzziDome	280
BuzziHat	284
BuzziJet	289
BuzziJet Standing	292
BuzziLight Mono	294
BuzziMoon	297
BuzziPleat Light	300
BuzziProp	304
BuzziShade	306
BuzziShade Square	310
BuzziShade Standing	312
BuzziSol	314
BuzziTrom	316
BuzziZepp Light	318

OUTDOOR

BuzziBreeze	323
BuzziNordic ST900	324
BuzziShed	327

MATERIALS

Upholstery	330
Curtains	368
Solid Materials	380

ACOUSTIC SOLUTIONS



BuzziBack — 32



BuzziBlinds Classic — 34



BuzziBlinds — 37



BuzziBlox — 41



BuzziBoard — 47

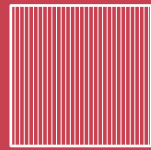

BuzziBrickBack — 49



BuzziBrickBack Architectural — 50



BuzziCactus — 52

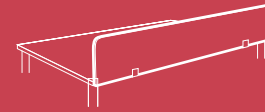

BuzziDesk — 55

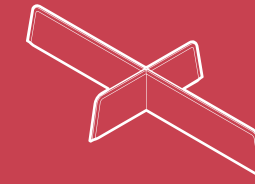

BuzziDesk Cross — 59



BuzziDesk FlipFlop — 60



BuzziDesk Split — 63



BuzziDish — 64

ACOUSTIC SOLUTIONS

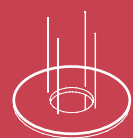

BuzziDonut — 66



BuzziFalls — 71



BuzziFalls Standing — 75



BuzziFree — 79



BuzziFrio — 81

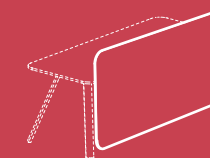

BuzziFrontDesk — 82

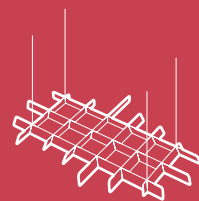

BuzziGrid — 85



BuzziGrip — 86

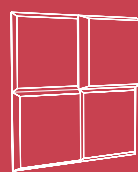

BuzziKey Soft — 89



BuzziLand — 91



BuzziLoose — 92

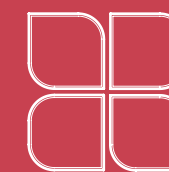

BuzziMood — 94



BuzziPlant — 97



BuzziPlanter — 98

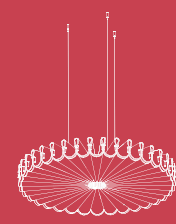

BuzziPleat — 102

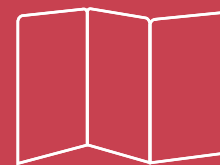

BuzziScreen — 106



BuzziScreen Mix — 108



BuzziShield Desk — 111

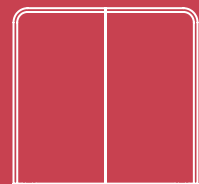

BuzziShield Free — 114

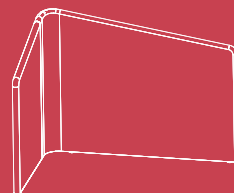

BuzziShield Hook — 116



BuzziSkin — 120



BuzziSkin Cuts — 123



BuzziSkin Printed — 124



BuzziTab Soft — 126



BuzziTile Flat — 128

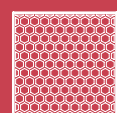

BuzziTile 3D — 130



BuzziTotem — 135



BuzziTripl Desk — 140



BuzziTripl Desk Split — 142

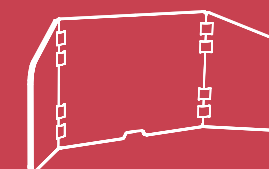

BuzziTripl Home — 144



BuzziTripl Wrap Desk — 146

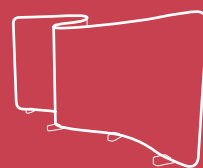

BuzziTwist — 149

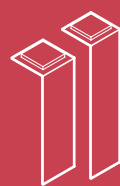

BuzziWings — 150

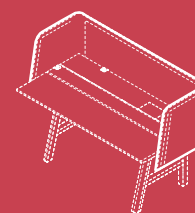

BuzziWrap Desk — 152



BuzziWrap FrontDesk — 154

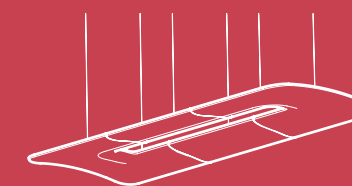

BuzziZepp — 156

BuzziBack

— by Sas Adriaenssens

Wall panel with adhesive tape or magnetic tape on backside

Spice up the back of your cabinets or your walls with the BuzziBack. Fully customizable, this acoustical treatment is available in different colors and tailored sizes. The sound-absorbing screen also acts as a pin board.



Dimensions

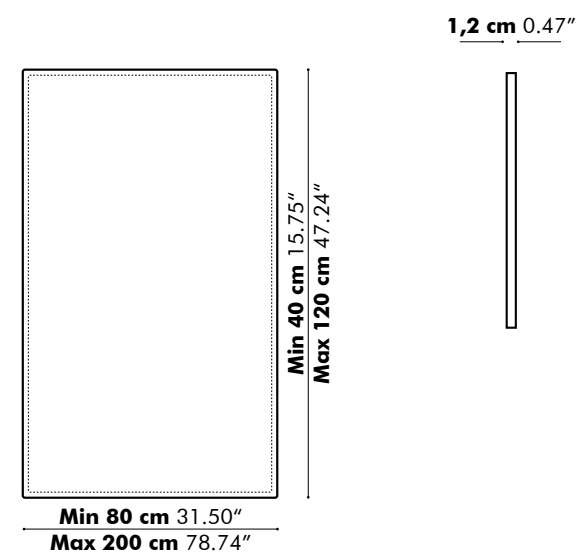

Finishes

2 layers of BuzziFelt stitched together
Extra layer in fabric collections CAT A, B, C, D, E, F possible
(check our application overview p. 330)



Mounting

Adhesive tape or magnetic tape on backside
Mounting on vertical surfaces only
Not recommended for ceiling applications

Acoustics

Acoustic Principles

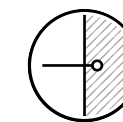

Absorption

Acoustic Performance



Mid Tones High Tones

How to order

Size (W x H)
BuzziFelt color
Mounting option



BuzziBlinds Classic

— By Alain Gilles

Room divider

These rotating acoustical blinds take their inspiration from modernist architecture—more specifically from the exterior sunshades that can be found on modernist buildings designed by Oscar Niemeyer. The free-standing room divider is made up of a series of five rotating acoustic blinds. With a simple twist, the blinds can be opened or closed to varying degrees to create privacy or open-up space. This gives individuals the opportunity to determine the level of privacy they may want or need at any given moment to concentrate on a specific task.



Volkswagen Financial IT offices - Berlin
Photography: Andrea Janssen



Dimensions

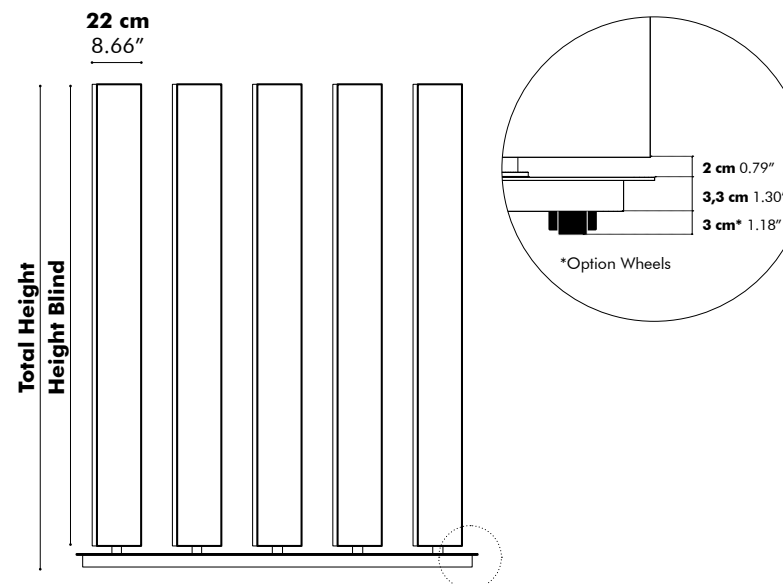

	Height Blind	Total Height
S	115 cm 45.28"	120,3 cm 47.36"
M	150 cm 59.06"	155,3 cm 61.14"
L	185 cm 72.83"	190,3 cm 74.92"

Baseplates

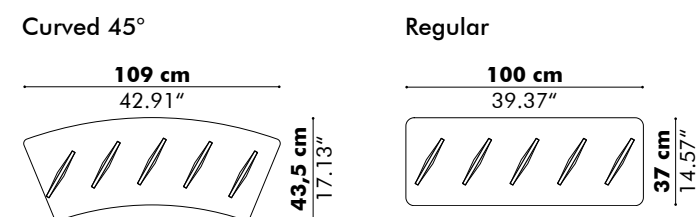

Finishes

Cover in BuzziFelt
Available in BuzziFelt Printed
Extra layer in fabric collections CAT A, B, C, D, E, F possible (check our application overview p. 330)
Baseplate in black (RAL 9005) or white (RAL 9010)

Options

Bicolor
Wheels (height + 3 cm | 1.18")

Acoustics

Acoustic Principles

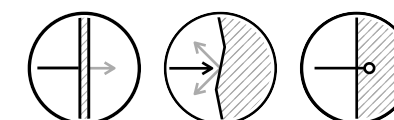

Attenuation Diffusion Absorption

Acoustic Performance

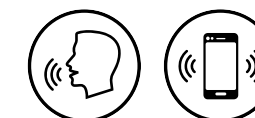

Mid Tones High Tones

How to order

Size
Model & color Baseplate
Fabric (CAT > collection > color)
Option



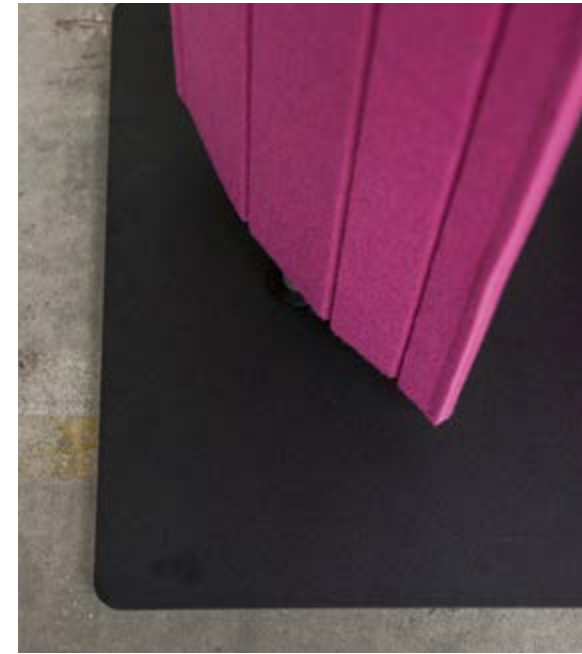

BuzziBlinds

— By Alain Gilles

Acoustical performance and privacy with a twist

New additions to the BuzziBlinds Classic. The new generation of BuzziBlinds offers 4 different shapes of the fins covered with plain BuzziFelt. The innovative v-cut technique strengthens the architectural and minimal look. The rhythm and tonalities created by the orientation of the v-cut add a dynamic of depth to any space.

Dimensions

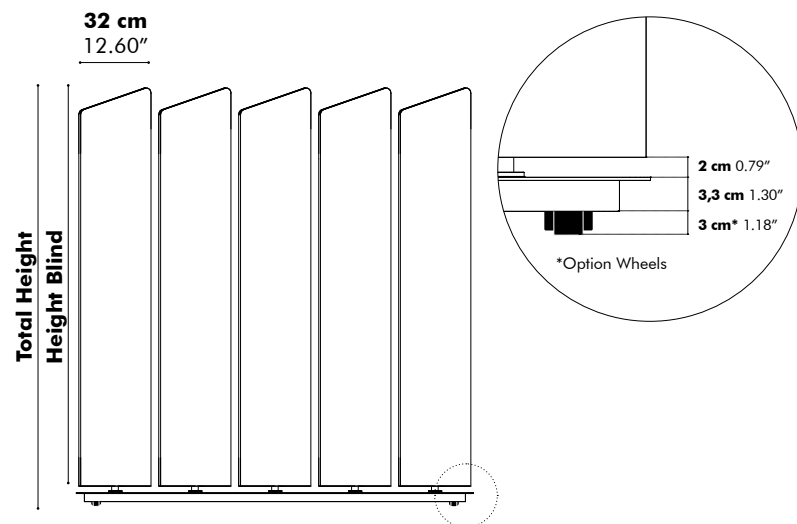

	Height Blind	Total Height
M	150 cm 59.06"	155,3 cm 61.14"
L	185 cm 72.83"	190,3 cm 74.92"

Baseplate

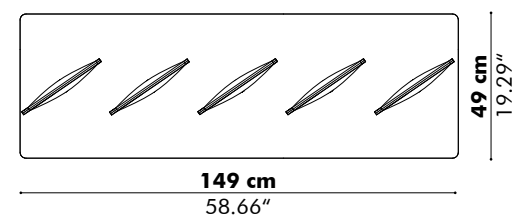

Models & Patterns

Blinds

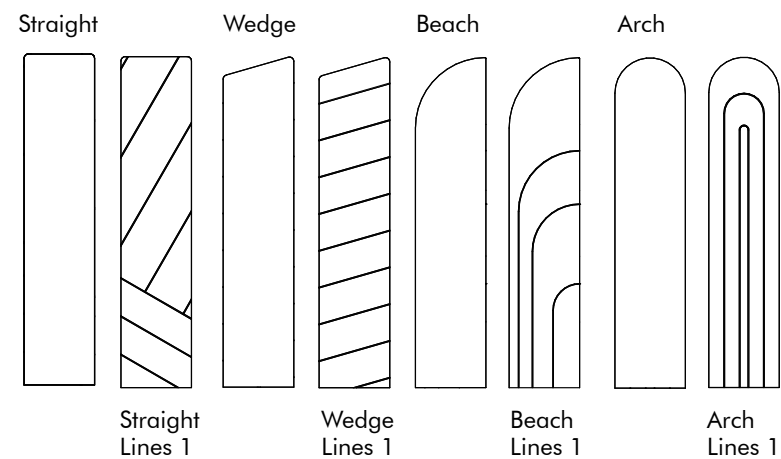

Finishes

Cover in BuzziFelt
 Available in BuzziFelt Printed
 Extra layer in fabric collections CAT A, B, C, D, E, F possible for Blinds without v-cut lines. (check our application overview p. 330)
 Baseplate in black (RAL 9005) or white (RAL 9010)

Options

Bicolor
 Wheels

Acoustics

Acoustic Principles

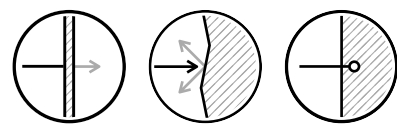

Attenuation Diffusion Absorption

Acoustic Performance

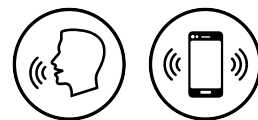

Mid Tones High Tones

How to order

Model & Pattern
 Size
 Color baseplate
 Fabric (CAT > collection > color)
 Option



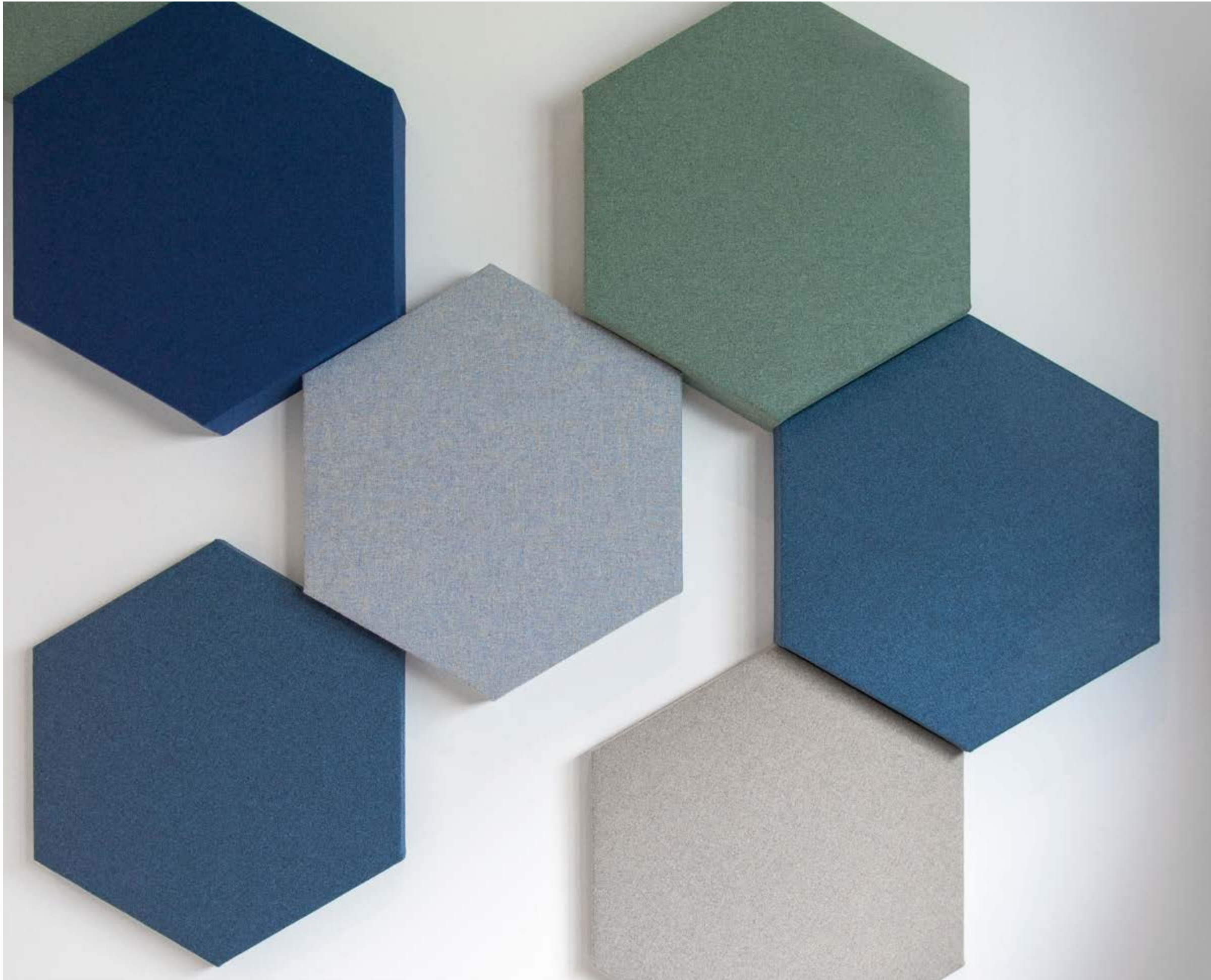

BuzziBlox

— By BuzziSpace Studio

Wall mounted or ceiling pendant acoustic panel

BuzziBlox is a group of acoustic panels with different depths, developed to tune a room in the speech spectrum range and especially in the low and mid frequencies.

By using alternating depths, the absorption of the different wavelengths into the thick layers of foam will be improved and make sure that the waves don't reflect into the room again. This diffusion effect will give the room a more pleasant sound experience. When placed against a wall, the Blox rather has the appearance of a piece of art while fully maintaining its initial purpose: to control and monitor the sound in any given room.

Models

Square

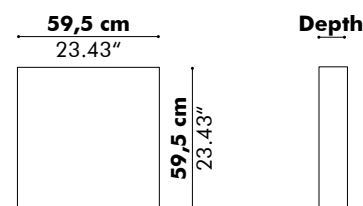

Depth Square	
SQ-4	4 cm 1.57"
SQ-8	8 cm 3.15"
SQ-12	12 cm 4.72"

Hexa

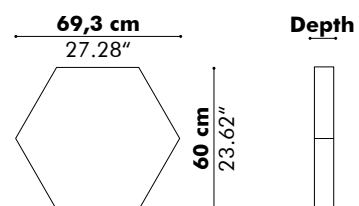

Depth Hexa	
Hexa-4	4 cm 1.57"
Hexa-8	8 cm 3.15"
Hexa-12	12 cm 4.72"

Square Wedge

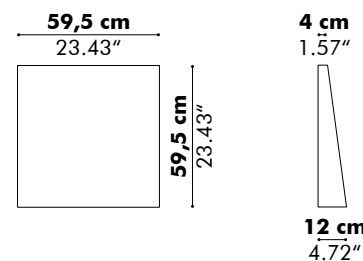

Hexa Wedge

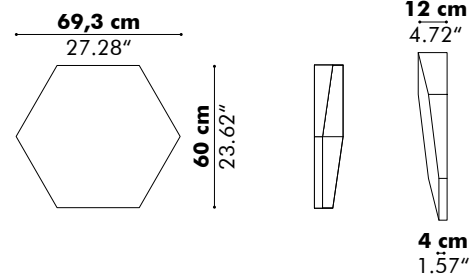

Rectangular

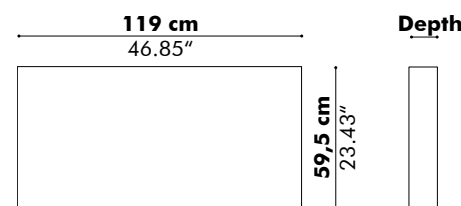

Depth Rectangular	
R-4	4 cm 1.57"
R-8	8 cm 3.15"
R-12	12 cm 4.72"

Penta

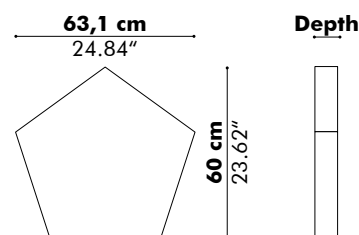

Depth Penta	
Penta-4	4 cm 1.57"
Penta-8	8 cm 3.15"
Penta-12	12 cm 4.72"

Rectangular WOLS

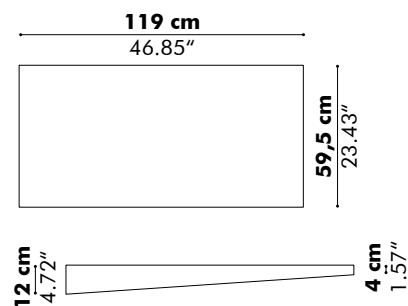

Penta Wedge

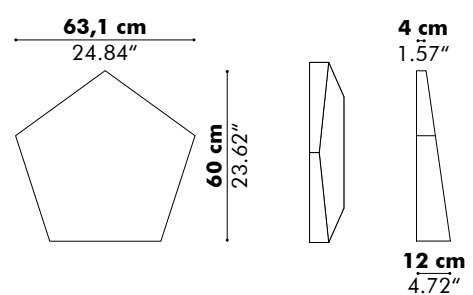

Rectangular WOSS

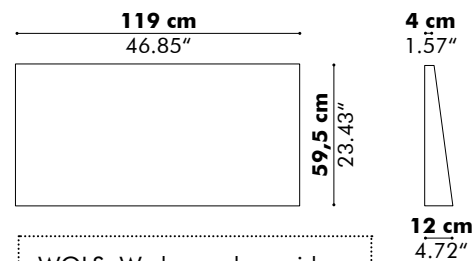

WOLS: Wedge on long side
WOSS: Wedge on short side

Rectangular XL*

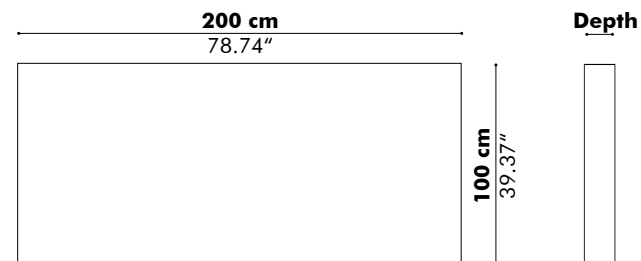

* Rectangular XL only wall mounted

Finishes

Upholstery in fabric collections CAT A, B, C, D, E, F (check our application overview p. 330)

Mounting

Fixing system: horizontal and vertical use possible

- Wall Mounted
Fixing System Wall
incl. wooden brackets (excl. screws for ceiling)
- Ceiling Suspended
Fixing System Screw with 4 cables of 2 m - 78.74" or 5 m - 196.85" (black or alu)
- Ceiling Suspended
Fixing System Magnet with 4 cables of 2 m - 78.74" or 5 m - 196.85" (black or alu)

Acoustics

Acoustic Principles

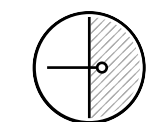

Absorption

Acoustic Performance



Low Tones Mid Tones High Tones

How to order

Model
Fabric (CAT > collection > color)
Mounting option





BuzziBoard

— by Sas Adriaenssens

Acoustic panel with power magnets in BuzziFelt

The BuzziBoard is a magnetic and sound-absorbing memo board that can be attached to metal surfaces or to both sides of a glass wall with no need for hooks or screws. You can use it to pin things up, to absorb sound or to darken your windows; in any case this multipurpose object invites you to use your imagination in the workplace or at home.

Dimensions

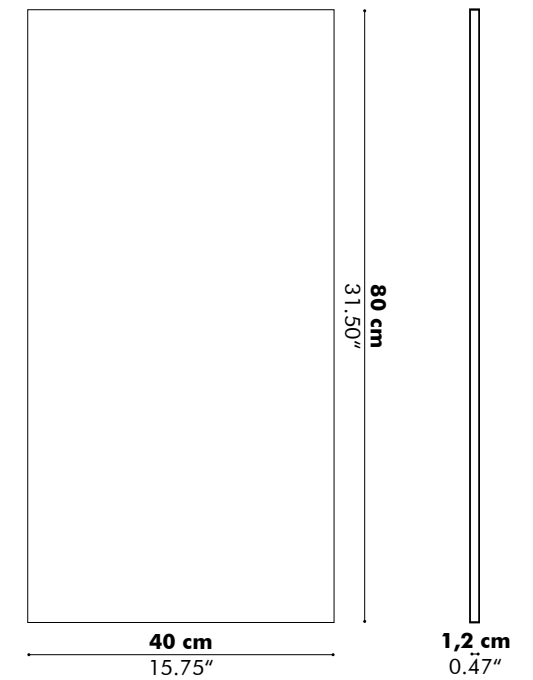

Finishes

2 layers of BuzziFelt with 6 power magnets

Mounting

On a metal wall

On a regular wall: use the metal strip

2 BuzziBoards with glass wall in between: gauge of glass max. 10 mm - 0.39"

Clear glass only, without osmose cleaning technique

Not recommended for ceiling applications

Acoustics

Acoustic Principles

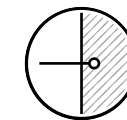

Absorption

Acoustic Performance



Mid Tones



High Tones

How to order

BuzziFelt color



Sigmax – Enschede
Photography: Toon Grobet



BuzziBrickBack

— by Sas Adriaenssens

Self-adhesive wall panel in sliced BuzziFelt

BrickBack is a unique looking sound-absorbing and self-adhesive panel. Made of sliced BuzziFelt in the size and color-mix you prefer. You can pin all kinds of things to it. It's functional and attractive in any office, home or hospitality environment.

Dimensions

Vertical stripes*

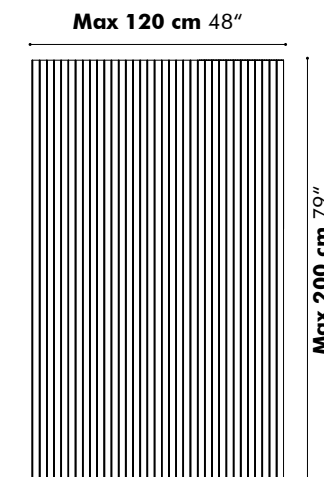

Horizontal stripes

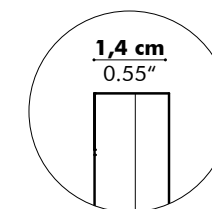
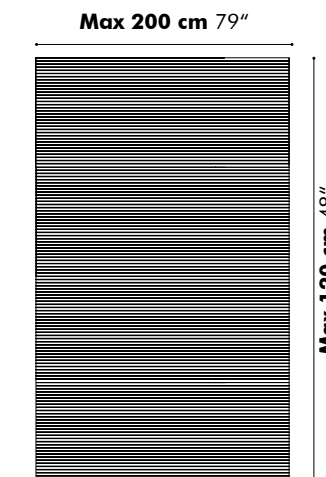

*For US production of vertical stripes max height 48", max width 79"

Finishes

Sliced BuzziFelt in unicolor, bicolor or multicolor
When installing several panels next to each other the stripes will not be in a continuous line
The seam will be visible (this is for all versions)
Variation in color & density may occur

Mounting

Self-adhesive backlayer
Not recommended for ceiling applications

Acoustics

Acoustic Principles

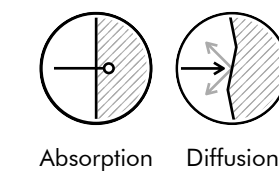

Absorption Diffusion

Acoustic Performance

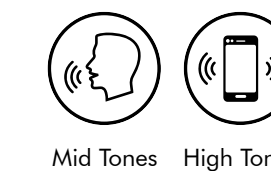

Mid Tones High Tones

How to order

Size (W x H)
Sliced BuzziFelt combination
Horizontal or vertical stripes

BuzziBrickBack Architectural

— by Sas Adriaenssens

A work of art

This architectural, sound-absorbing wall brings blank walls back to life. Made of multiple layers of sound-absorbing BuzziFelt in monochrome colors, this easy-to-install solution reduces high-frequency tones, while creating visual interest with its tactile, linear pattern. The versatile surface can also serve as a bulletin board to pin up memos, notes, photos and inspiration.

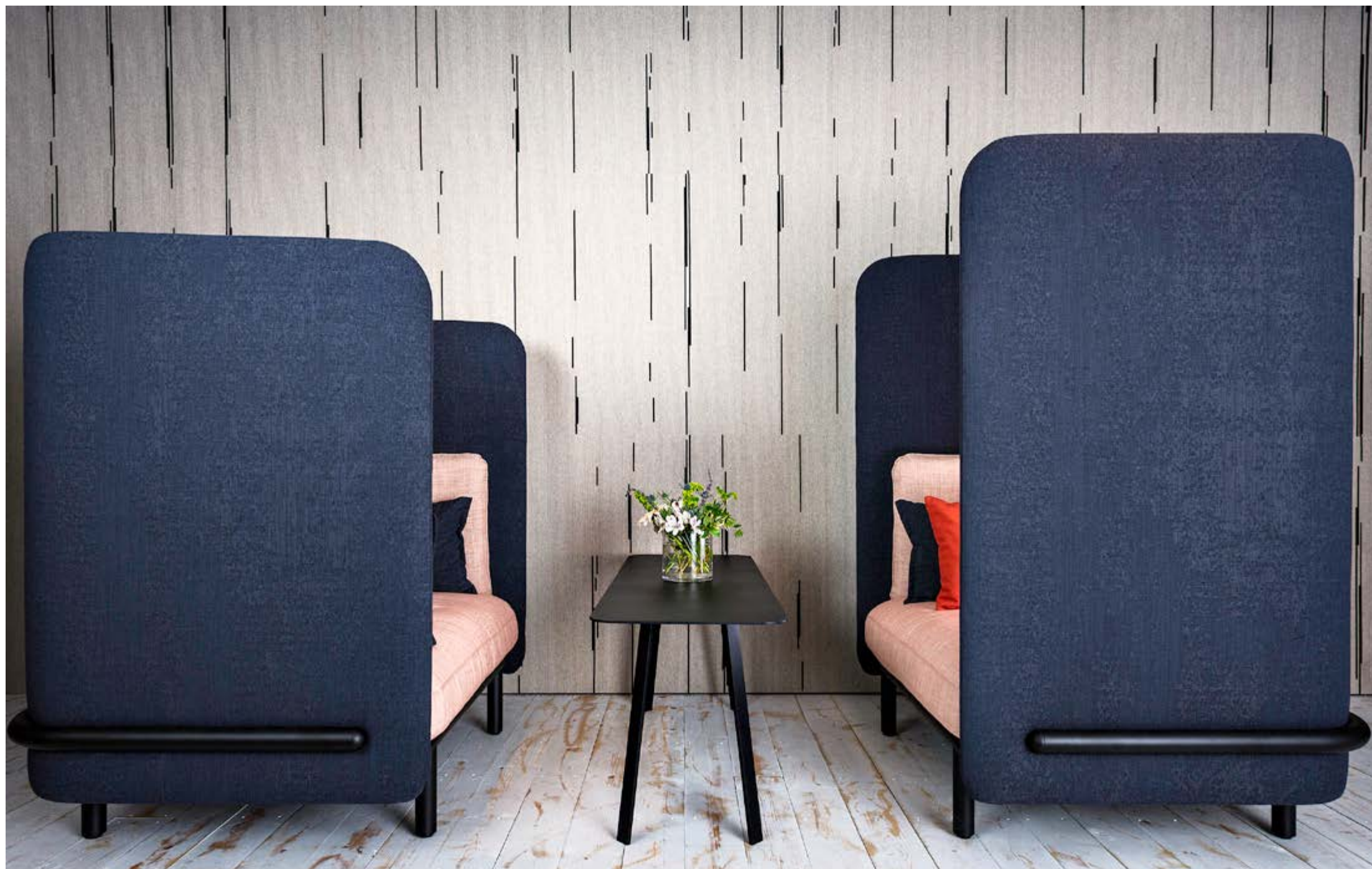

Dimensions

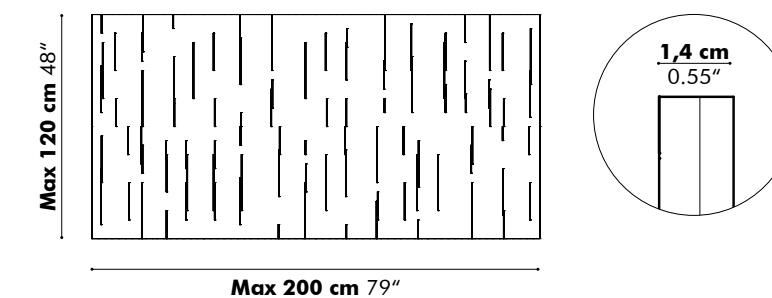

Panels can be mounted horizontally or vertically.

Finishes

Sliced BuzziFelt in Anthracite and OffWhite

When installing several panels next to each other the stripes will not be in a continuous line

The seam will be visible

Variation in density may occur

Mounting

Self-adhesive back layer

Not recommended for ceiling/floor applications

Acoustics

Acoustic Principles

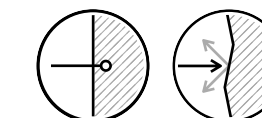

Absorption Diffusion

Acoustic Performance

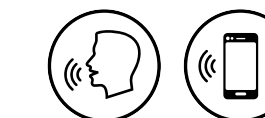

Mid Tones High Tones

How to order

Size (W x H)

Sliced Felt combination

Horizontal or vertical stripes

BuzziCactus

— by Sas Adriaenssens

Free-standing sound-absorbing screen

Do you need privacy, quiet or protection? The BuzziCactus is a charming room divider that combines no less than three factors: sound absorption, design and a surface you can stick pins onto. Thanks to its striking shape and color you can make a statement at home or at the office. Put your BuzziCactus in direct sunlight – it deserves to be seen!



Aviva Digital Garage - Toronto
Photography: Steve Tsai

Models

Taco

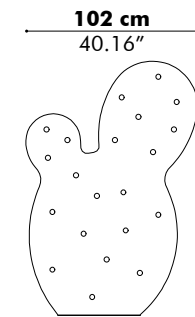

Gringo

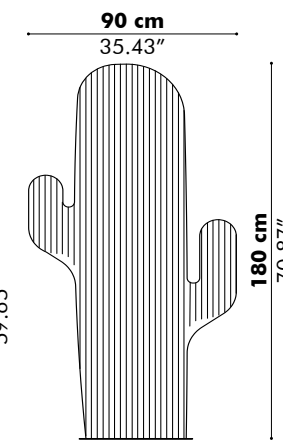

TexMex

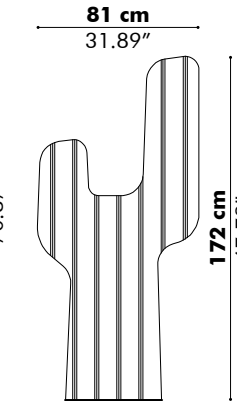

Baseplate

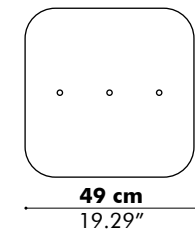

Finishes

Upholstery in fabric collections CAT A, B, C, D, E (check our application overview p. 330)
Baseplate in black (RAL 9005) or alu color (RAL 9006)

Acoustics

Acoustic Principles

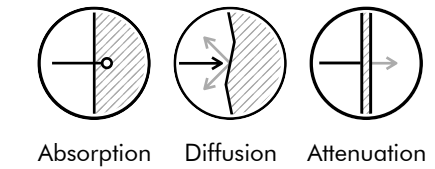

Absorption Diffusion Attenuation

Acoustic Performance



Low Tones Mid Tones High Tones

How to order

Model
Fabric (CAT > collection > color)
Color baseplate





BuzziDesk

— by BuzziSpace Studio

Desk divider screen with metal profile

Not only does the BuzziDesk safeguard your privacy at work; it keeps out your colleagues' irritating telephone or computer sounds as well. This workspace divider also hides your cable clutter and computer screen in an orderly fashion. It is easy to install in any office, and with its tactile appearance and colorful tint it will make every working day feel like a party!



Dimensions

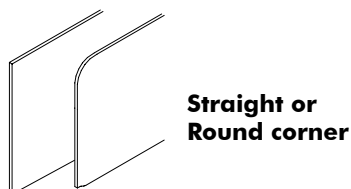
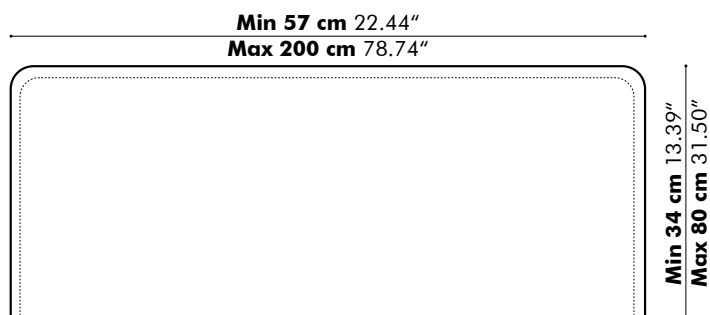

Finishes

Cover in BuzziFelt
 Extra layer in fabric collections CAT A, B, C, D, E, F possible
 (check our application overview p. 330)
 BuzziFix in black (RAL 9005), white (RAL 9010) or alu color (RAL 9006)

Options

Bicolor

Acoustics

Acoustic Principles

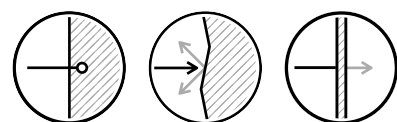

Absorption Diffusion Attenuation

Acoustic Performance



Mid Tones High Tones

How to order

Size (W x H)
 Fabric (CAT > collection > color)
 Straight or Round corner
 BuzziFix
 Options

BuzziFix

Bold

L

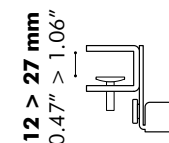

L-Plus

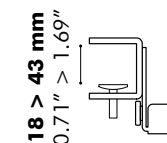

XL

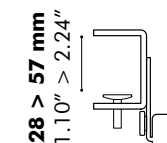

Twin**

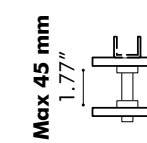

Magnet*

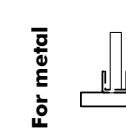

Part A

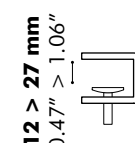

Part D

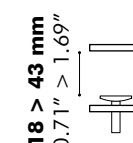

Part B

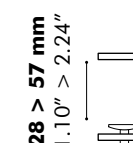

Part C

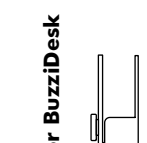

* Magnet only to be used for BuzziDesk:
 H ≤ 40 cm - 15.75" and W ≤ 160 cm - 62.99"
 ** Screws included

Thin

F L

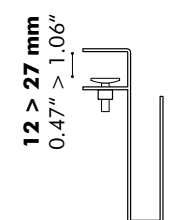

F L-plus

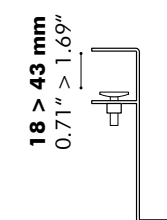

F XL

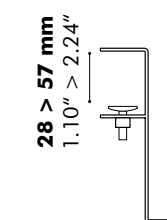

U

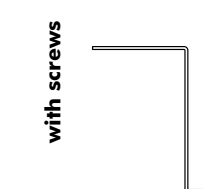

Y L

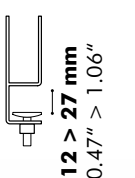

Y L-plus

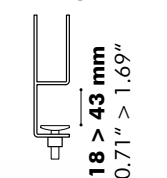

Y XL

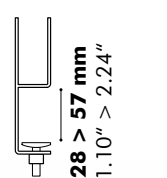

Twin Light**

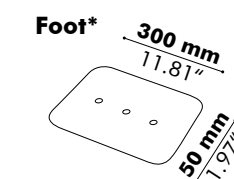
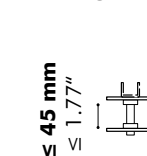

* Foot only to be used with BuzziDesk:
 H ≤ 40 cm - 15.75" and W ≤ 160 cm - 62.99"
 ** Screws included





BuzziDesk Cross

— by BuzziSpace Studio

Divide by four

Desk sharing encourages collaboration and perhaps that is why it's becoming increasingly common in many workspaces. Meeting tables are turned into workstations housing several employees who each requires personal space and privacy from time to time. To accommodate such requests, BuzziDesk Cross is the ideal solution as it transforms a meeting table into four individual workstations.

Dimensions

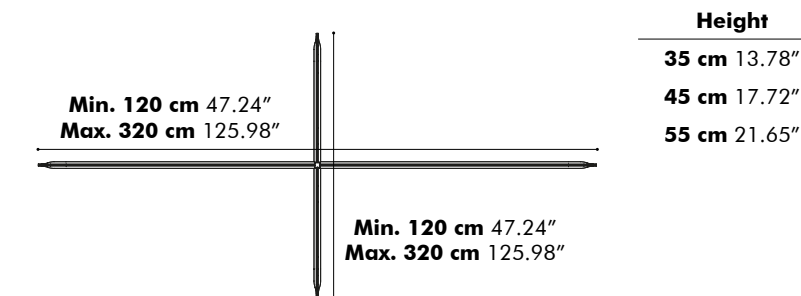

Finishes

Cover in BuzziFelt
Extra layer in fabric collections CAT A, B, C, D, E, F possible (check our application overview p. 330)

Options

Sliders for BuzziPicNic WorkBench
Multifabric: Panels A & B in varying materials belonging to the same CAT (CAT A-F). No bicolor option available, only one fabric & color per panel.

Acoustics

Acoustic Principles

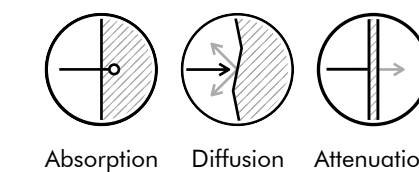

Absorption Diffusion Attenuation

Acoustic Performance



Mid Tones High Tones

How to order

Height panels
Total width panel A
Total width panel B
Fabric (CAT > collection > color)
Options

BuzziDesk FlipFlop

— by Alain Gilles

Free-standing desk divider screen

These movable and foldable acoustic screens have been designed in order to instantly define a quieter and more personal space on any desktop. They can be conveniently stored against a wall in a flat manner since their side flaps are fully movable. They can be used in a more or less closed manner depending on how protected one wants to be, but can also be set in a zig-zag manner on a table top. They were originally designed to be used on the multifunctional BuzziPicNic table (with two small extra sliders that fit perfectly in its central opening), but they can be used on any tabletop to define a specific area when needed.

Dimensions

Height		Side		Length midpart	
35 cm	13.78"	37.5 cm	14.76"	80 cm	31.50"
50 cm	19.69"	50 cm	19.69"	100 cm	39.37"
				120 cm	47.24"
				140 cm	55.12"
				160 cm	62.99"
				180 cm	70.87"
				200 cm	78.74"

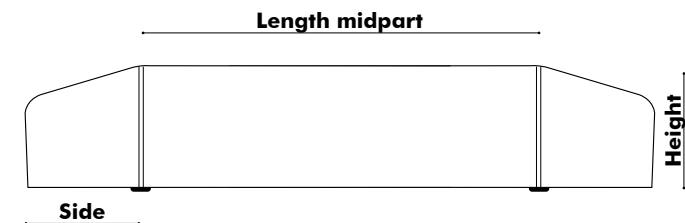

Finishes

Upholstery in fabric collections CAT A, B, C, D, E, F (check our application overview p. 330)

Options

Sliders for BuzziPicNic WorkBench (2 pieces)
Fix Wall (2 pieces or 3 pieces) in white (RAL 9010), black (RAL 9005) or alu color (RAL 9006)

Acoustics

Acoustic Principles

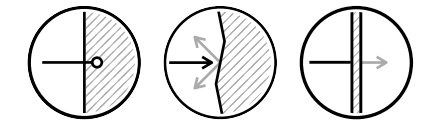

Absorption Diffusion Attenuation

Acoustic Performance

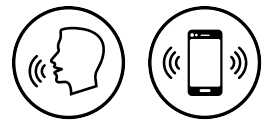

Mid Tones High Tones

How to order

Size (height, side, length midpart)
Fabric (CAT > collection > color)
Options



Varonis - New York
Photography: Liam Frederick

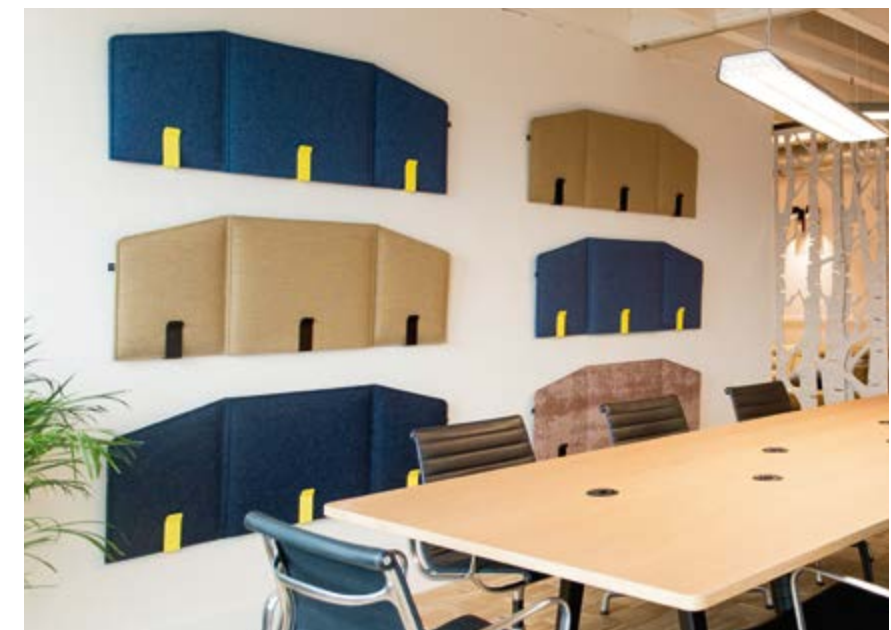

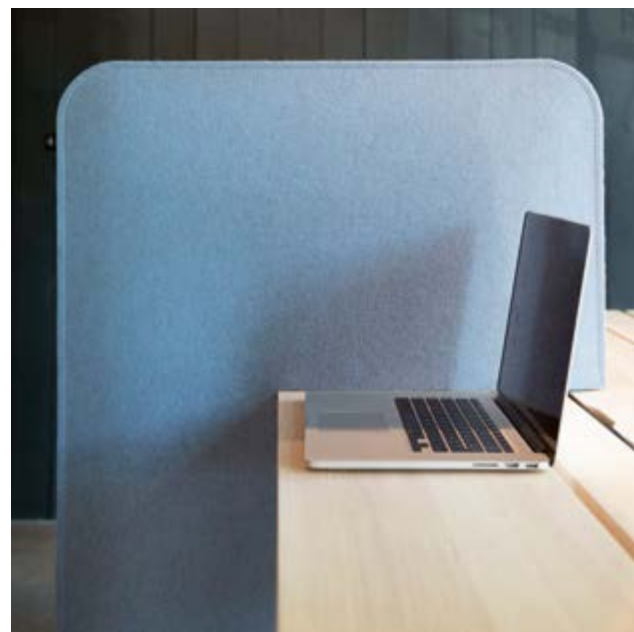

BuzziDesk Split

— by BuzziSpace Studio

Desk divider screen for more privacy

Are you sitting at one big table next to different colleagues? With the BuzziDesk Split you can gain more privacy by creating a personal and quiet workspace. Just slide the sound-absorbing BuzziDesk Split over the table and say goodbye to irritating sounds or elbow fights!

Dimensions

A	B	C
45 cm 17.72"	45 cm 17.72"	25 cm 9.84"
65 cm 25.59"	65 cm 25.59"	45 cm 17.72"
85 cm 33.46"		65 cm 25.59"

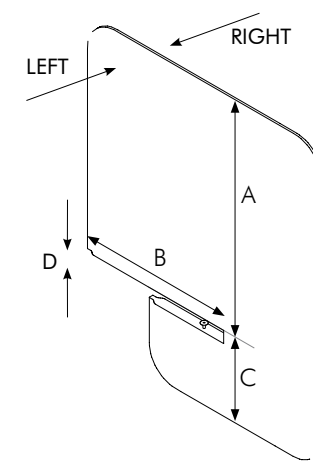

D	L	L Plus	XL
12>27 mm 0.47">1.06"	22>43 mm 0.87">1.69"	45>57 mm 1.77">2.24"	

Finishes

Cover in BuzziFelt

Mounting

Desk mounted
Worktop Fix (L, L Plus, XL)

Options

Bicolor (different color left / right)

Acoustics

Acoustic Principles

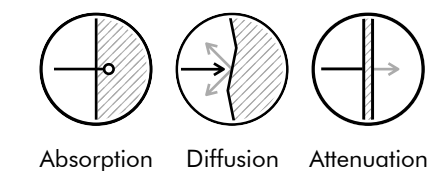

Absorption Diffusion Attenuation

Acoustic Performance

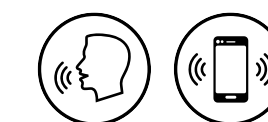

Mid Tones High Tones

How to order

Size (A, B, C)
BuzziFelt color
Straight or Round corner
Size fix

BuzziDish

— by Jeffrey Huyghe

A playful high-performance acoustic solution with rotating capabilities

Playful exterior, complex interior. BuzziDish marries design and function with the recognizable shape, reminiscent of a satellite dish. Featuring a fabric-upholstered body paired with a perforated structure and acoustic foam core interior, BuzziDish's parabolic, concave design efficiently mitigates noise by absorbing undesired sound waves. With a rotating connector, attached to the back of the outside curvature, BuzziDish offers additional functionality and flexibility. Combine an array of panels and turn the body in different directions for added acoustic impact and visual interest—create something never seen before!

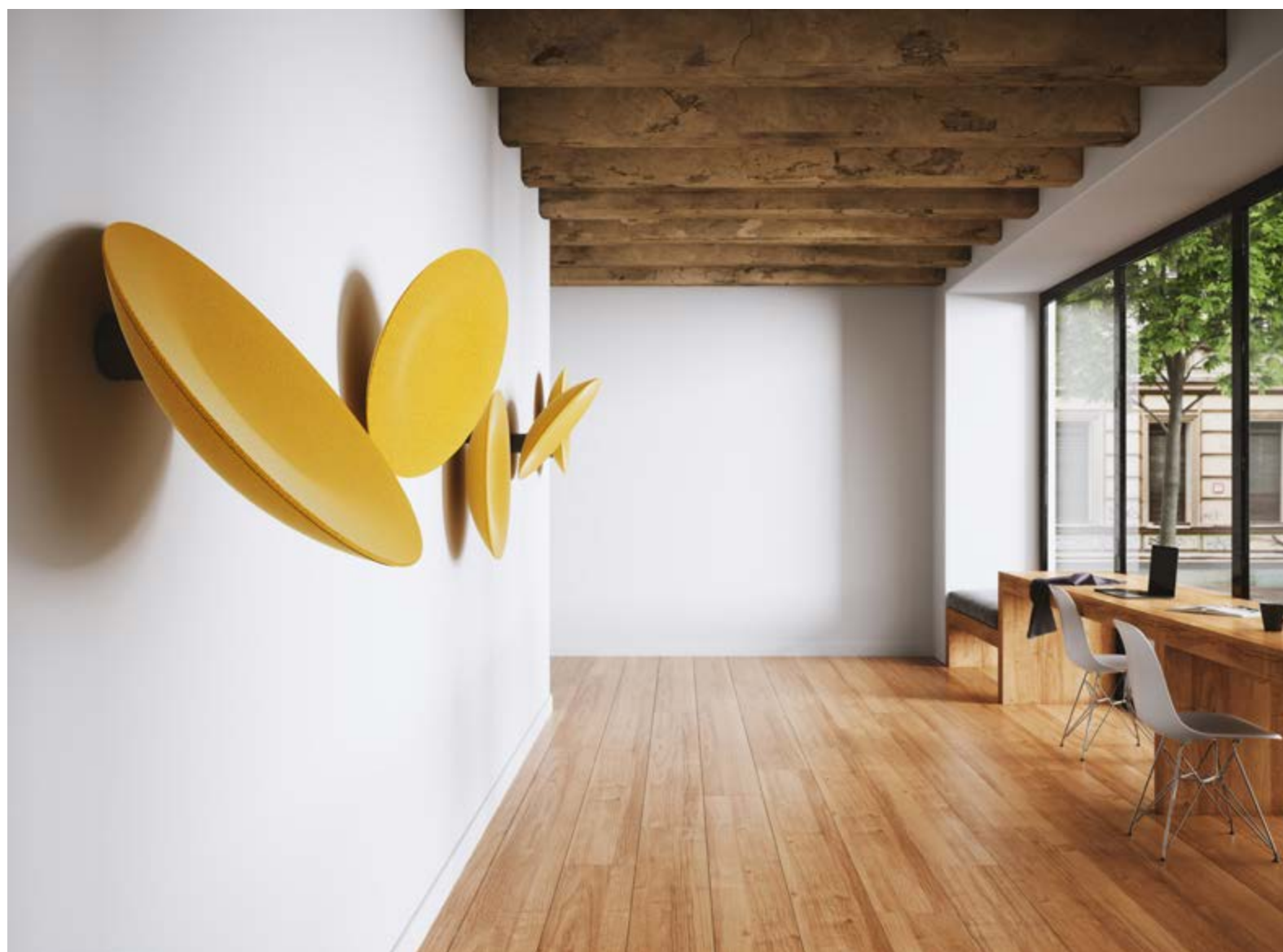

Dimensions

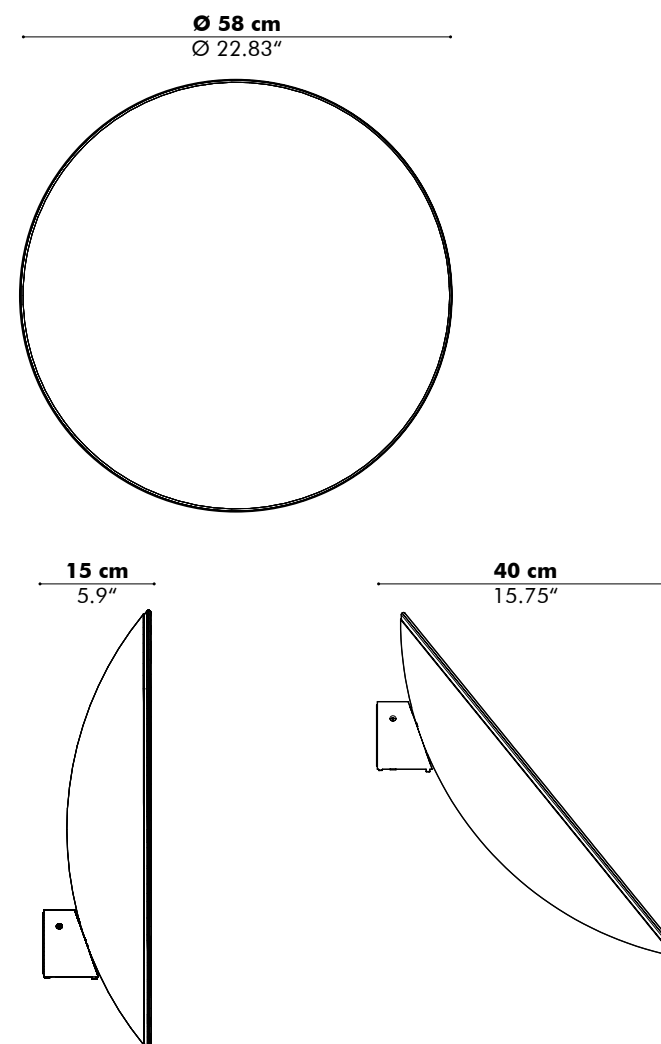

Finishes

Wall / Ceiling connection part in Black (RAL 9005)
Upholstery in fabric CAT A, B, C, D, E
(Check our application overview p. 330)

Mounting

Fixing System Wall / Ceiling included
BuzziDish is rotatable in two directions and can be locked with two set screws.

Options

Bicolor

Acoustics

Acoustic Principles

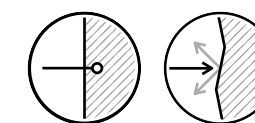

Absorption Diffusion

Acoustic Performance

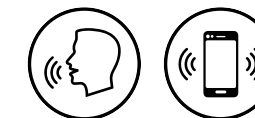

Mid Tones High Tones

How to order

Fabric (CAT > collection > color)
Option



BuzziDonut

— by BuzziSpace Studio

Sound-absorbing panel with central hole

A round, sound-absorbing panel with a distinctive central hole that gives it its tasty name. The sleek round form, standardly upholstered or finished off with a 3D print, is available in all the colors of the BuzziSpace spectrum. The BuzziDonut improves the acoustic qualities of a space.



Dimensions

S
 ø 80 cm ø 31.50" **M**
 ø 100 cm ø 39.37" **L**
 ø 120 cm ø 47.24"

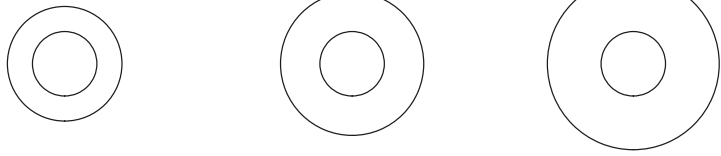

Patterns

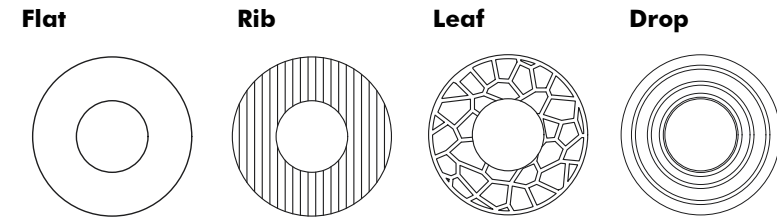

Finishes

Upholstery in fabric collections CAT A, B, C, D, E, F
 (check our application overview p. 330)

Mounting



Wall Mounted
 Fixing System Wall
 incl. 2 x 2 wooden brackets (excl. screws for ceiling)

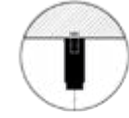

Ceiling Suspended
 Fixing System Screw with 4 cables of 2 m - 78.74" or
 5 m - 196.85" (black or alu)



Ceiling Suspended
 Fixing System Magnet with 4 cables of 2 m - 78.74" or
 5 m - 196.85" (black or alu)

Options

Upholstered back

Acoustics

Acoustic Principles

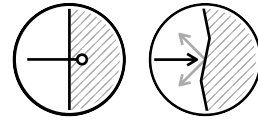

Absorption Diffusion

Acoustic Performance

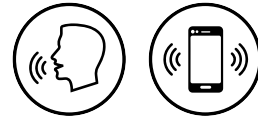

Mid Tones High Tones

How to order

Size
 Pattern
 Fabric (CAT > collection > color)
 Mounting option
 Options





BuzziFalls

— by Sas Adriaenssens

An artful room divider in BuzziFelt

Partition a space and create a layer of privacy with BuzziFalls, a collection of floating, decorative panels, which offer artistic style with acoustic benefits. Designed to tackle the challenges unique to open-floor plan environments, BuzziFalls is an elegant art piece and room-dividing solution in one. Made of dual layer BuzziFelt, these sound-absorbing panels are precision cut with bold patterns, available in a range of organic, geometric and cityscape motifs.

The BuzziFalls Rail enables BuzziFalls to be slid with ease — creating movable room dividers that shift from private to public space. Running on a single three-meter track, panels slide from left to right. To create the effect of sliding doors, install two layers of parallel tracks for the rails. BuzziFalls can be attached directly to the surface of the track rail or suspended and exists in a black or white color.

Dimensions

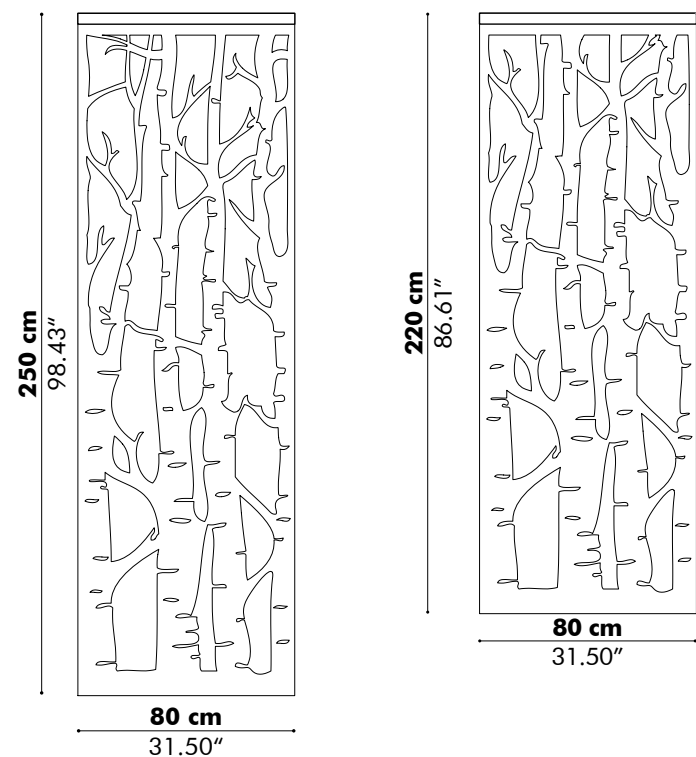

Patterns

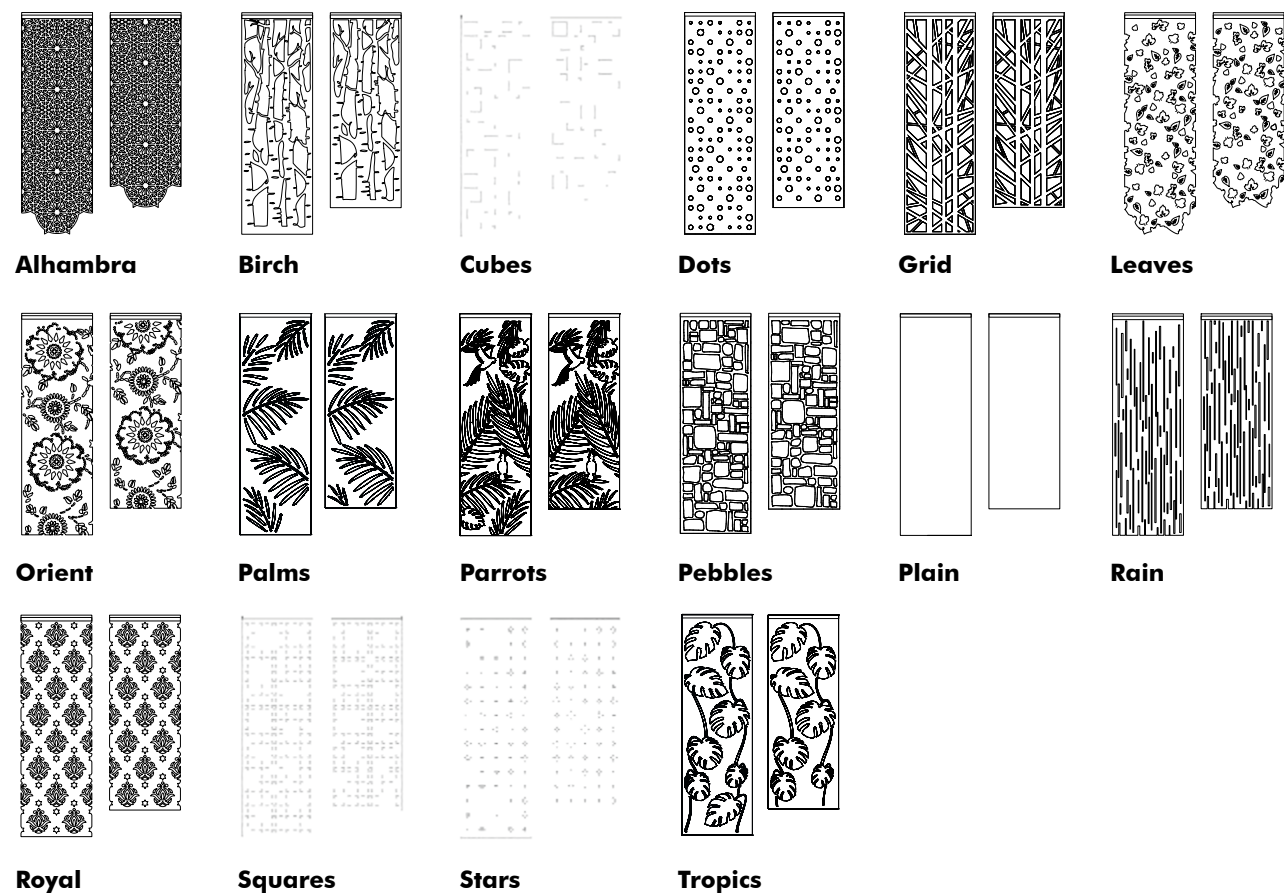

Finishes

2 layers of BuzziFelt and metal profile in black (RAL 9005) or white (RAL 9010)
Available in BuzziFelt Printed

Mounting

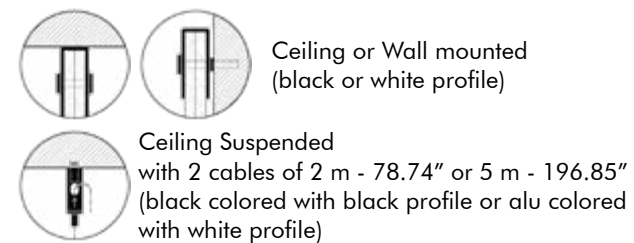

Options

Bicolor
Rail System: 320 cm - 125.98"
(for 1-3 Falls)
Extra rail for extension
in black or white

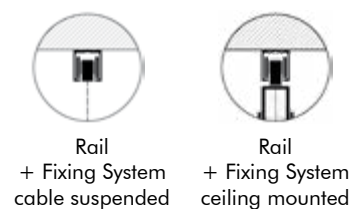

Acoustics

Acoustic Principles

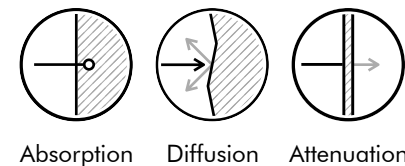

Acoustic Performance



How to order

Size
Pattern
BuzziFelt* color
Mounting option
Color profile
Options

*Not available in Ecobrown 58.





BuzziFalls Standing

— by Sas Adriaenssens

A playful folding screen in BuzziFelt

BuzziFalls, our playful room divider that was launched in 2014, is also available in a free-standing folding screen. Our 'Trio' version consists of 3 panels and is ideal to divide your office or room any way you want. It also exists in a single model which you can expand by adding multiple +1 panels. Personalize it by choosing a striking BuzziFelt color and one of our different patterns.

Models

Single

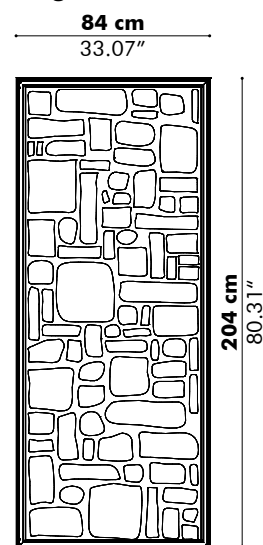

2 baseplates are always included

Trio

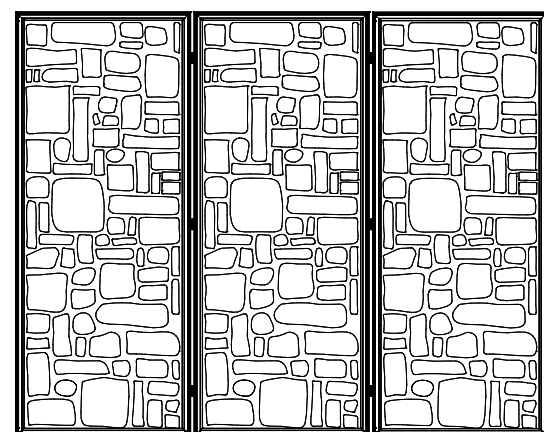

6 adjustable feet and hinges are always included, baseplate optional

+1

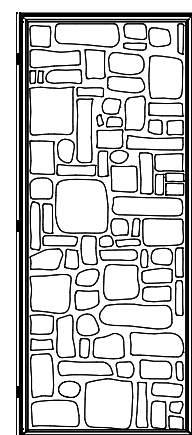

2 adjustable feet and hinges are always included

Patterns

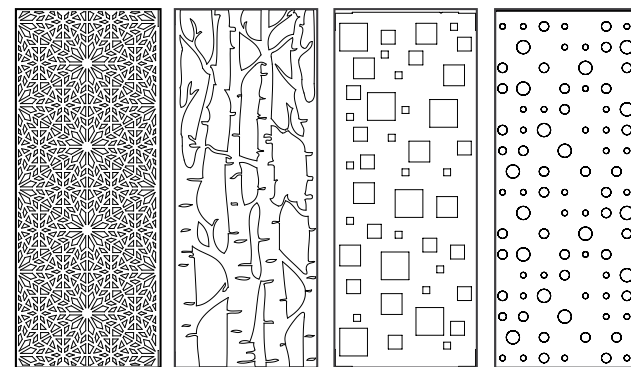

Alhambra **Birch** **Cubes** **Dots**



Grid **Leaves** **Orient** **Palms**

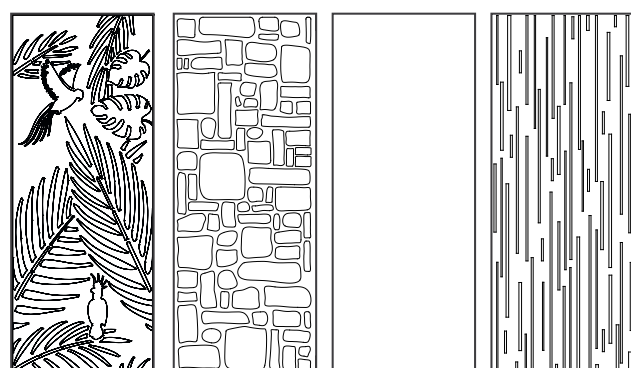

Parrots **Pebbles** **Plain** **Rain**

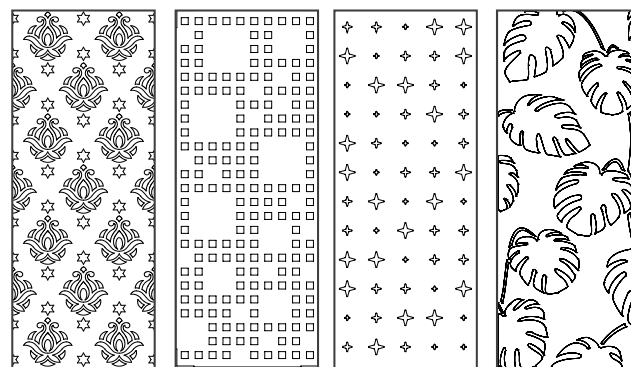

Royal **Squares** **Stars** **Tropics**

Finishes

Coated alu frame in black (RAL 9005)
Falls in BuzziFelt
Available in BuzziFelt Printed

Options

Baseplate (2 pieces included with BuzziFalls Standing Single)
Bicolor

Acoustics

Acoustic Principles

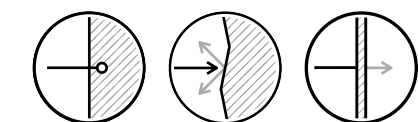

Absorption Diffusion Attenuation

Acoustic Performance



High Tones

How to order

Model
Pattern
BuzziFelt* color
Options

*Not available in Ecobrown 58.





BuzziFree

— by BuzziSpace Studio

Free-standing screen

The BuzziFree can stand on its own, dividing a room into two parts while improving visual and sound comfort. This mobile room divider is simple by design. The product is made of BuzziFelt.

Dimensions

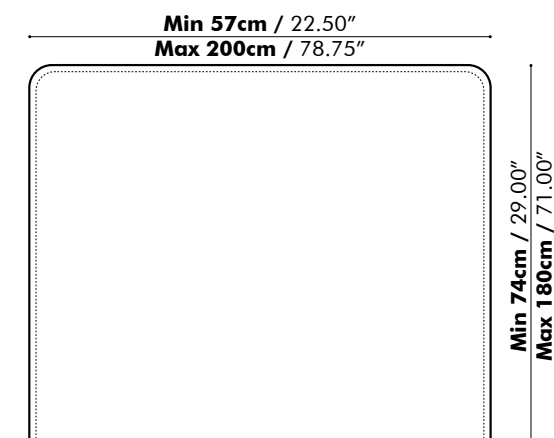

Baseplates

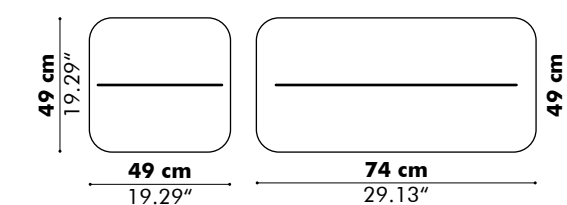

Finishes

Cover in BuzziFelt

Extra layer in fabric collections CAT A, B, C, D, E, F possible
(check our application overview p. 330)

Baseplate in alu color (RAL 9006) or black (RAL 9005)

Options

Bicolor

Acoustics

Acoustic Principles

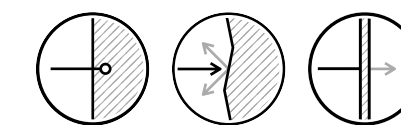

Absorption Diffusion Attenuation

Acoustic Performance

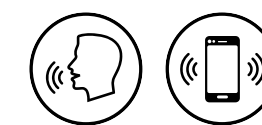

Mid Tones High Tones

How to order

Size (H x W)

Fabric (CAT > collection > color)

Color baseplate



BuzziFrio

— by BuzziSpace Studio

Set of three acoustic panels

Fresh mountain air would work wonders on office workers, but sadly bringing all that air into the city to ventilate workspaces would be quite a challenge. BuzziSpace has the next best thing. The shape of the BuzziFrio Machu and BuzziFrio Pichu room dividers recalls the rocky mountains of Peru, thus visually transforming an office space into a wide-open landscape. The playful shapes bring a touch of humor to the office, a defining trait of BuzziSpace.

As BuzziFrio consists of three panels set closely together, it has a large surface area that enables it to effectively regulate sound in a space. BuzziFrio is available in the standard BuzziSpace fabrics and can also be covered with fabrics from selected Kvadrat collections.

Models

	Width	Height
S	120 cm 47.24"	120 cm 47.24"
M	120 cm 47.24"	150 cm 59.06"
L	120 cm 47.24"	180 cm 70.87"

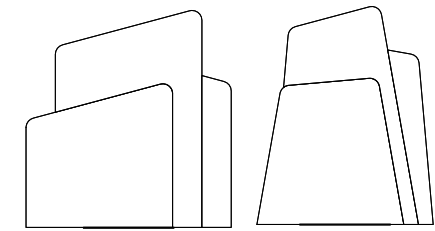

Machu

Pichu

Baseplate

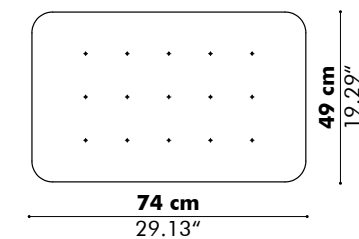

Finishes

Cover in BuzziFelt

Extra layer in fabric collections CAT A, B, C, D, E, F possible (check our application overview p. 330)

Multicolor: All panels (S, M & L) in one material, panels can be ordered in different colors, only one color per panel

Multifabric: Panels (S, M & L) in varying materials, only one material & color per panel

Baseplate in alu color (RAL 9006) or black (RAL 9005)

Acoustics

Acoustic Principles

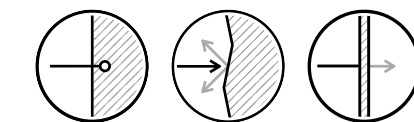

Absorption Diffusion Attenuation

Acoustic Performance



Low Tones Mid Tones High Tones

How to order

Model

Multicolor or multifabric

Fabric per panel (CAT > collection > color)

Color baseplate

BuzziFrontDesk

— by BuzziSpace Studio

Front panel for worktop

This workspace divider safeguards your privacy at work or at home. Hide away your cable clutter and computer screen in an orderly fashion. Easy to install on any workstation.



Dimensions

Height above desk	Total height	Width
25 cm 9.84"	90 cm 35.43"	100 cm 39.37"
35 cm 13.78"	100 cm 39.37"	120 cm 47.24"
45 cm 17.72"	110 cm 43.30"	140 cm 55.12"
		160 cm 62.99"
		180 cm 70.87"

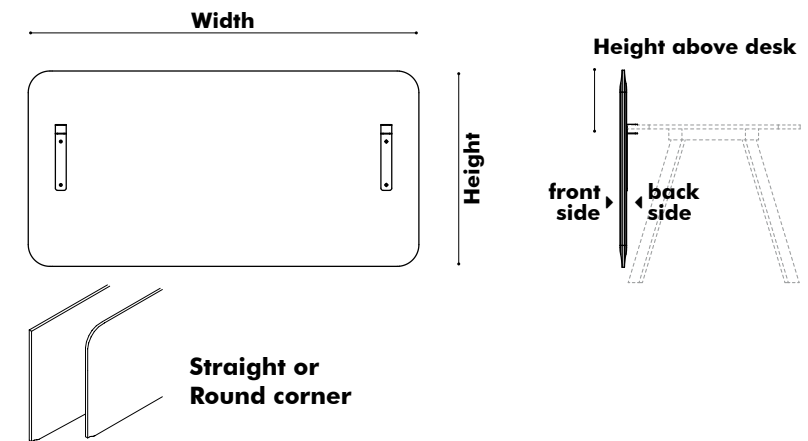

Finishes

Cover in BuzziFelt
Extra layer in fabric collections CAT A, B, C, D, E, F possible
(check our application overview p. 330)

Mounting

Desk mounted
Fix - L - worktop thickness 12 mm - 0.47" > 27 mm - 1.06"
Fix - L Plus - worktop thickness 18 mm - 0.71" > 43 mm - 1.69"
Fix - XL - worktop thickness 28 mm - 1.10" > 57 mm - 2.24"
Fix - XXL - worktop thickness 72 mm - 2.83" > 98 mm - 3.86"
Fix in black (RAL 9005), alu color (RAL 9006) or white (RAL 9010)

Options

Bicolor

Acoustics

Acoustic Principles

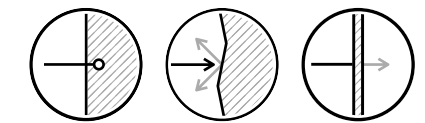

Absorption Diffusion Attenuation

Acoustic Performance

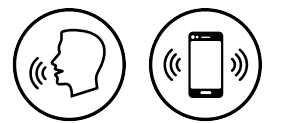

Mid Tones High Tones

How to order

Size (H x W)
Straight or Round corner
Fabric (CAT > collection > color)
Size fix
Color fix
Options





Realsys – London Offices
Photography: Ani Sarpe

BuzziGrid

— by Alain Gilles

Ceiling element in BuzziFelt

The BuzziGrid is a sound buffer that limits echo in a room. It takes its inspiration from the structures that have been widely used in the 60s and 70s to partially hide ceilings in public spaces. In this case the grid has been turned into a functional sound-absorbing product that can be used in meeting rooms, lobbies, or other public spaces to define areas.

Dimensions

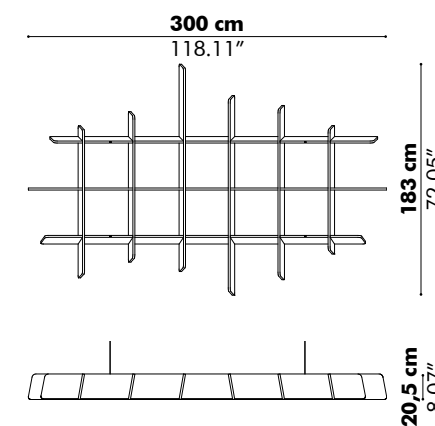

Finishes

2 layers of BuzziFelt on white PVC

Mounting

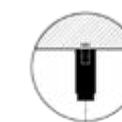

Ceiling Suspended
Fixing System Screw
with 4 cables of 2 m - 78.74" or 5 m - 196.85"
(alu colored)

Options

Bicolor (every panel has one side in a different color)

Acoustics

Acoustic Principles

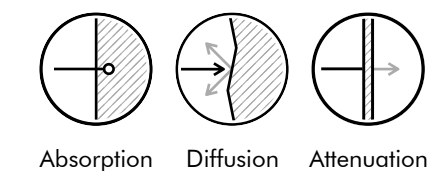

Absorption Diffusion Attenuation

Acoustic Performance

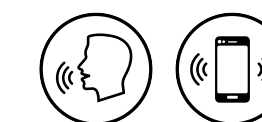

Mid Tones High Tones

How to order

BuzziFelt color
Options
Mounting option



Realsys – London Offices
Photography: Ani Sarpe

BuzziGrip

— by Sas Adriaenssens

Acoustic panel with suction cups in BuzziFelt

All the advantages of the BuzziBoard combined with suction cups on the back, allowing for easy attachment to cupboards or windows. Wherever you put it, you keep your life organized with a cool look and a hint of rebellion.



Dimensions

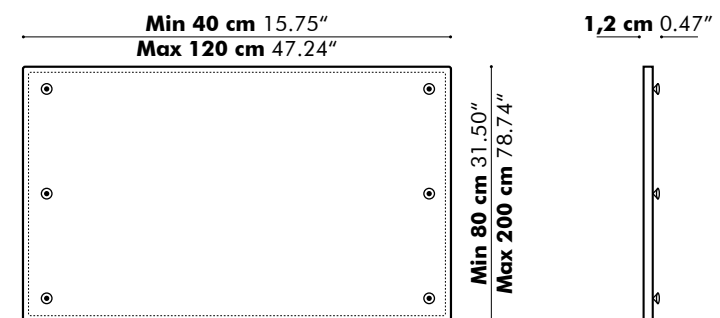

Finishes

2 layers of BuzziFelt stitched together

Mounting

Panel attached to a surface with suction cups
For vertical use only
Not recommended for ceiling applications

Acoustics

Acoustic Principles

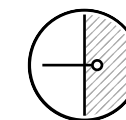

Absorption

Acoustic Performance



High Tones

How to order

Size (W x H)
BuzziFelt color





BuzziKey Soft

— by BuzziSpace Studio

A playful acoustic panel attuned to modern spaces
 BuzziKey Soft offers exceptional sound-absorption capabilities ensuring an acoustically well-balanced space that is never out of tune! The soft exterior and chamfered edges create an intriguing blend of contrasts that help break the hard surfaces and lines of a space. BuzziKey Soft lightens and softens walls all while upholding a sense of familiarity with the classic acoustic panel. It's back to basics, yet attuned to modern spaces and interiors alike. Play with perspectives and add depth of field with different models, available in various sizes and depths, and choose your favorite color combinations for a distinctive look.

Models

Square

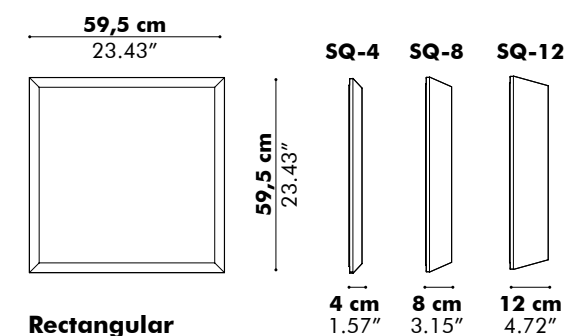

Rectangular

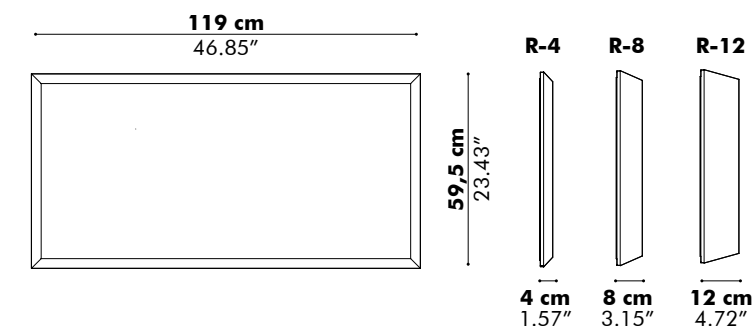

Finishes

Upholstery in CAT A, B, C, D, E, F (check our application overview p. 330)

Acoustics

Acoustic Principles

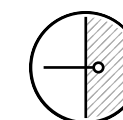

Absorption

Acoustic Performance



Low Tones



Mid Tones



High Tones

Mounting

BuzziKey Soft Fixing System included.
 (horizontal or vertical mounting)

How to order

Model
 Fabric (CAT > collection > color)





BuzziLand

— by BuzziSpace Studio

Sound-absorbing panel

Large office spaces or residential lofts often echo, which can be distracting or impact productivity. BuzziSpace has developed the BuzziLand, a sound-absorbing panel that can be fixed to the ceiling or walls to dampen sound waves while still offering a chic design.

Models

- S** 80 cm x 120 cm 31.50" x 47.24"
- M** 80 cm x 160 cm 31.50" x 62.99"
- L** 100 cm x 180 cm 39.37" x 70.87"
- XL** 120 cm x 200 cm 47.24" x 78.74"

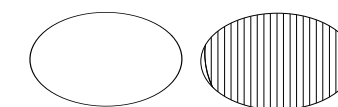

- S** Ø 80 cm Ø 31.50"
- M** Ø 100 cm Ø 39.37"
- L** Ø 120 cm Ø 47.24"

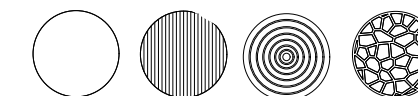

180 cm x 105 cm 70.87" x 41.34"





*Only Ceiling Suspended

Finishes

Upholstery in fabric collections CAT A, B, C, D, E (check our application overview p. 330)

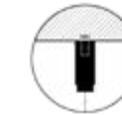
Mounting

-  Wall Mounted
Fixing System Wall
incl. 2 x 2 wooden brackets (excl. screws for ceiling)
-  Ceiling Suspended
Fixing System Screw with 4 cables of 2 m - 78.74" or 5 m - 196.85" (black or alu)
-  Ceiling Suspended
Fixing System Magnet with 4 cables of 2 m - 78.74" or 5 m - 196.85" (black or alu)

Acoustics

Acoustic Principles

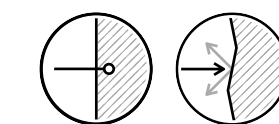

Absorption Diffusion

Acoustic Performance

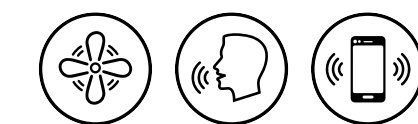

Low Tones Mid Tones High Tones

How to order

- Model
- Size
- Pattern
- Fabric (CAT > collection > color)
- Mounting option

BuzziLoose

— by BuzziSpace Studio

Sound-attenuating suspended panel

The BuzziLoose is a sound attenuating panel that can be fixed to the ceiling to reduce the sound transfer in a room while still offering a chic design. Ideal for reducing the echo in a large office space or residential loft.



Dimensions

	Width	Height
XS	80 cm 31.50"	60 cm 23.62"
S	120 cm 47.24"	80 cm 31.50"
M	160 cm 62.99"	80 cm 31.50"
L	180 cm 70.87"	100 cm 39.37"
XL	200 cm 78.74"	120 cm 47.24"

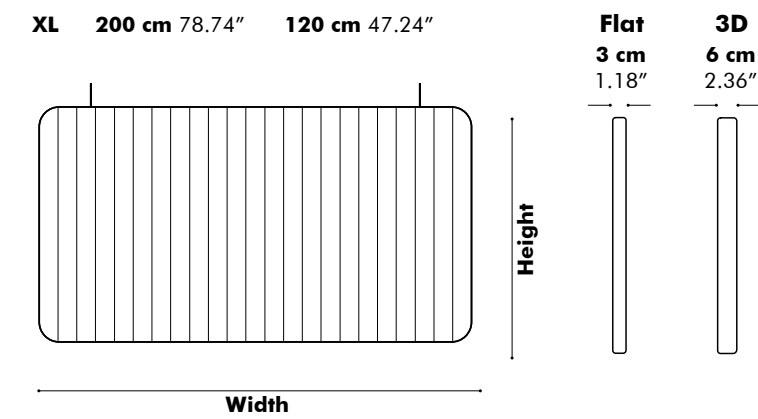

Patterns

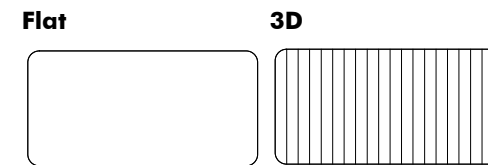

Finishes

Cover in BuzziFelt
Extra layer in fabric collections CAT A, B, C, D, E, F possible (check our application overview p. 330)

Mounting

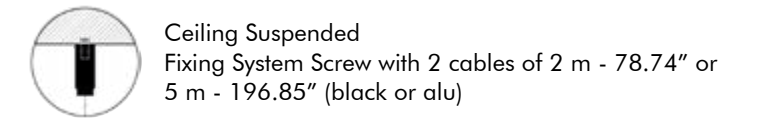

Options

Bicolor

Acoustics

Acoustic Principles

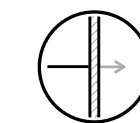

Attenuation

Acoustic Performance



Low Tones Mid Tones High Tones

How to order

- Size
- Pattern
- Fabric (CAT > collection > color)
- Mounting option
- Options

BuzziMood

— by Cory Grosser + Associates

Lift up your mood

Let your imagination run wild and create your own graphic wall art. BuzziMood is an acoustical wall solution that offers the possibility to combine materials found in nature with upholstered pads in a range of different fabrics and geometrical shapes. This blend mitigates noise and serves as a natural air humidity indicator too when mixed with moss panels. Choose between two moss colors, a light and dark green, to create varying degrees of contrast against the metal frames. As the name suggests, this acoustic solution will undoubtedly lift up your mood in any setting.



Models

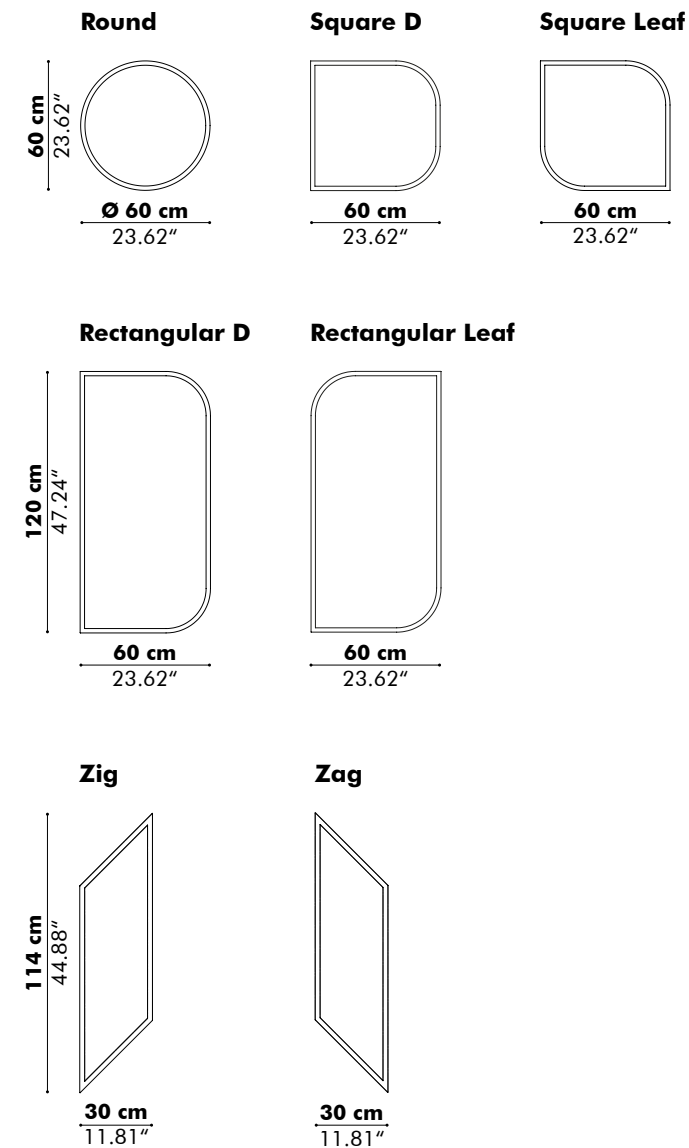

Panels

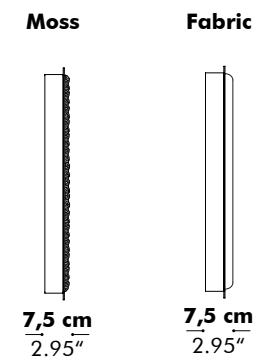

Finishes

Metal frame in black (RAL 9005) or fluo yellow (RAL 1016)
 Panel in moss (light green or dark green) or upholstered in fabric
 collections CAT A, B, C, D, E, F
 (check our application overview p. 330)

Acoustics

Acoustic Principles

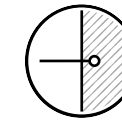

Absorption

Acoustic Performance



Mid Tones



High Tones

How to order

Model
 Color frame
 Panel (moss or fabric)
 Color panel: color moss / fabric (CAT > collections > color)



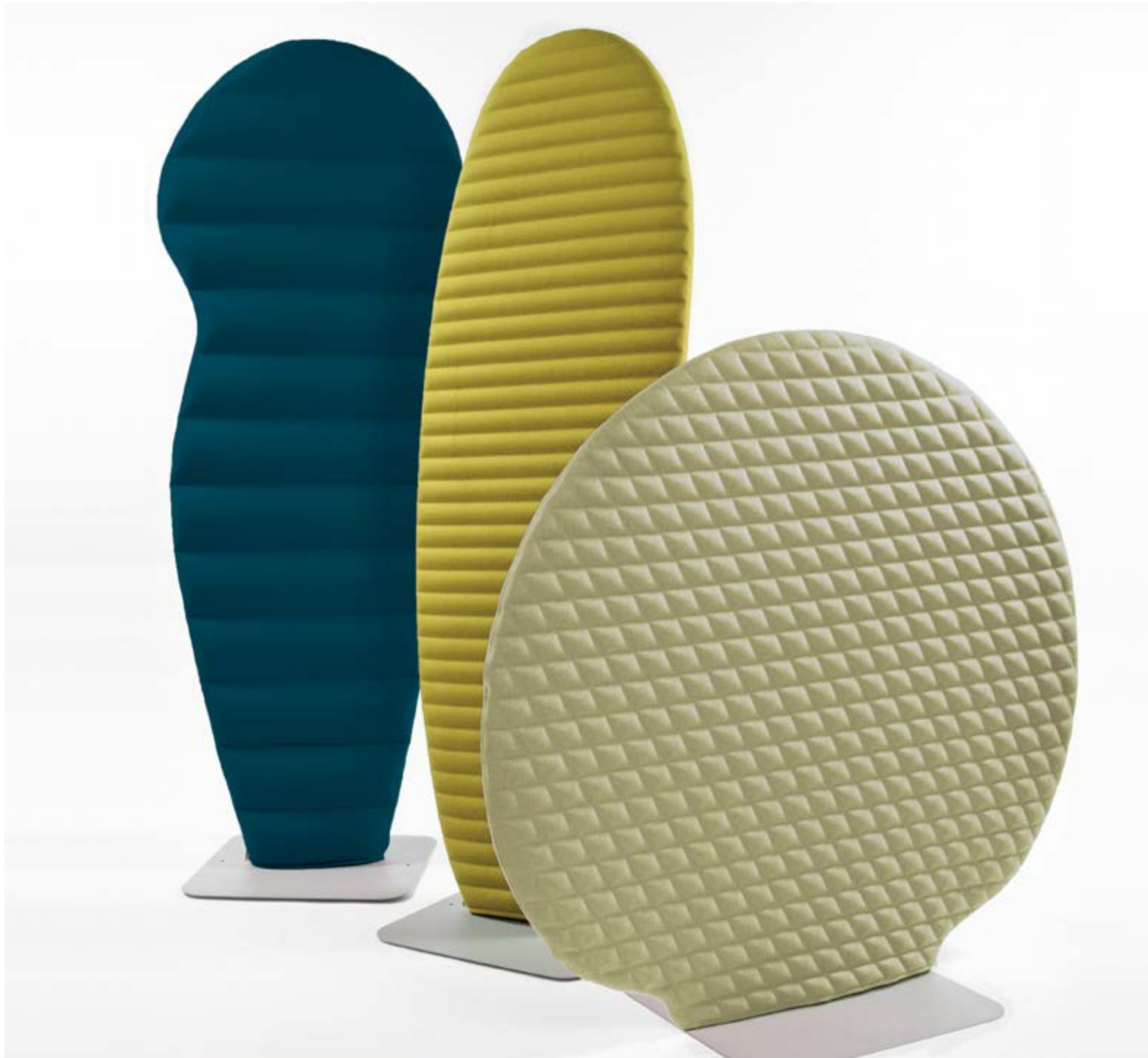

BuzziPlant

— by Anthony Duffeleer

Free-standing sound-absorbing screen

The BuzziPlant by designer Anthony Duffeleer is a fun-loving, decorative room divider that balances sound. Thanks to the striking shape and color of the three available plants, you can make a statement at home or at the office.

Models

Surf

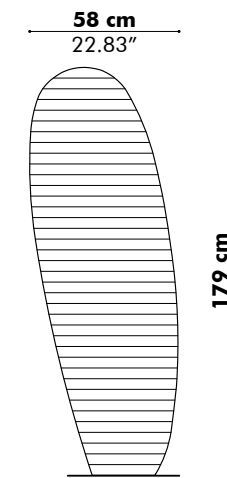

Doldi

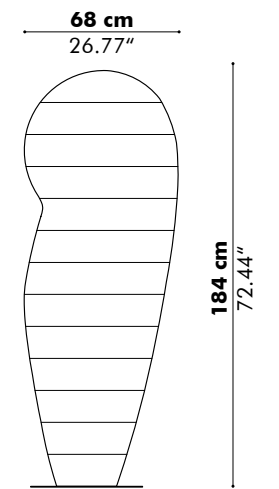

Mobi

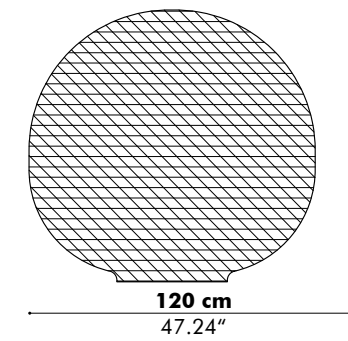

Baseplate

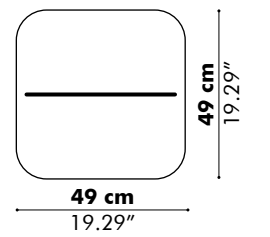

Finishes

Upholstery in fabric collections CAT A, B, C, D, E (check our application overview p. 330)
Baseplate in alu color (RAL 9006) or black (RAL 9005)

Acoustics

Acoustic Principles

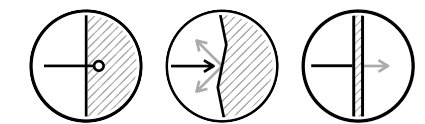

Absorption Diffusion Attenuation

Acoustic Performance



Low Tones Mid Tones High Tones

How to order

Model
Fabric (CAT > collection > color)
Color baseplate

BuzziPlanter

— by BuzziSpace Studio

A biophilic office divider

BuzziPlanter is an upholstered colorful pot made from high-density foam. Arriving in six different size variations, BuzziPlanter helps to divide open spaces into luscious green microenvironments, creating calm and peaceful areas to work, gather, and relax. However, BuzziPlanter's superpower is absorbing excessive noise in open spaces, creating healthier environments for people to thrive.



Models

BuzziPlanter 45

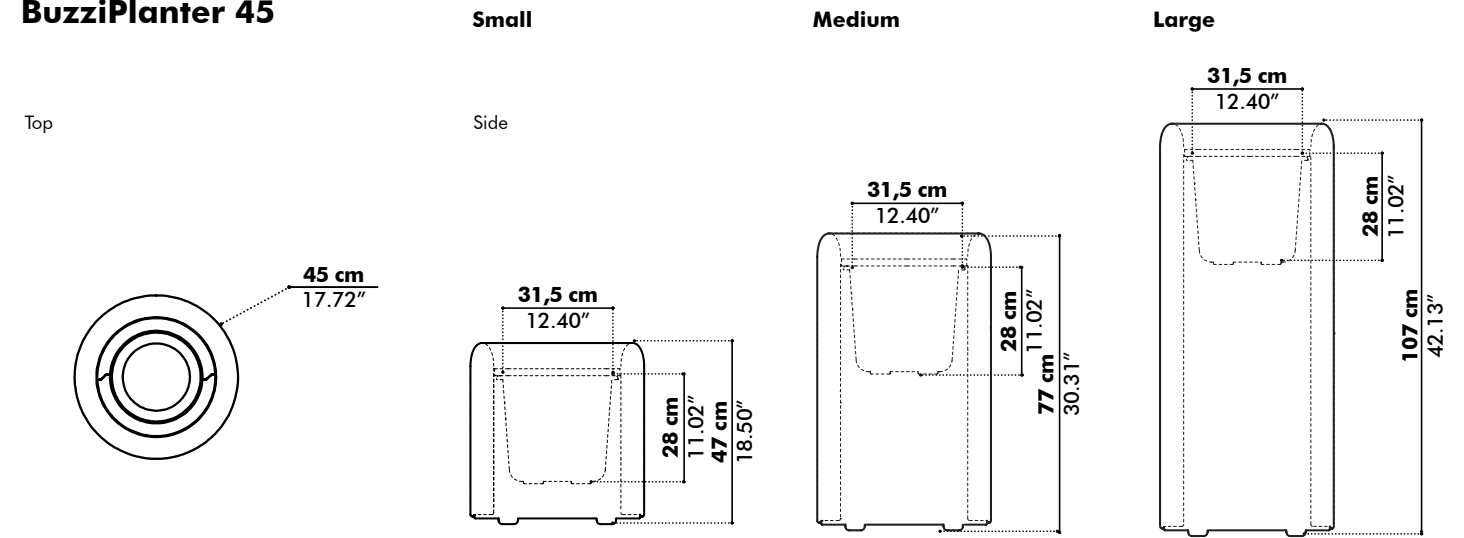

BuzziPlanter 45 Long

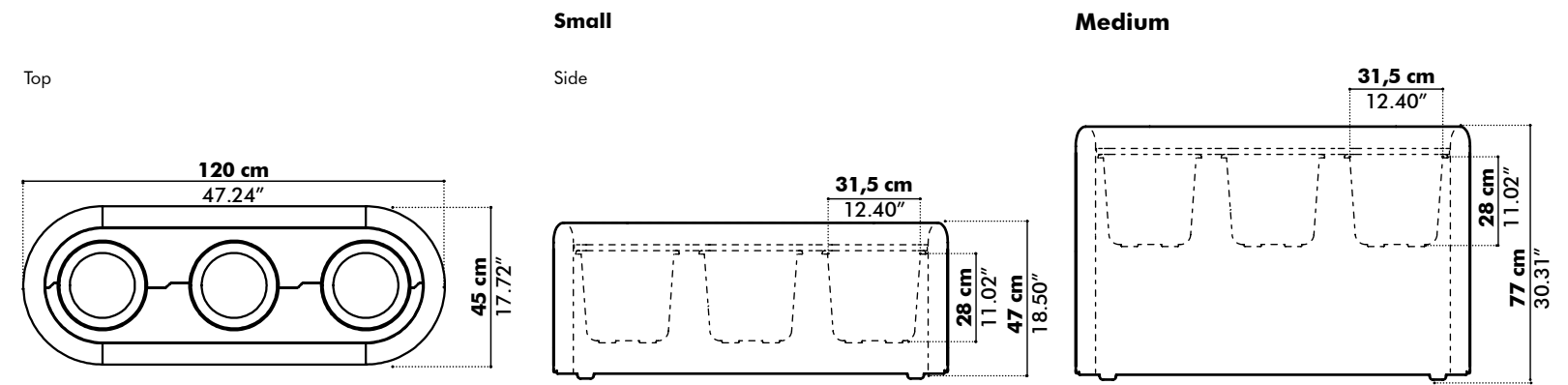

BuzziPlanter 80

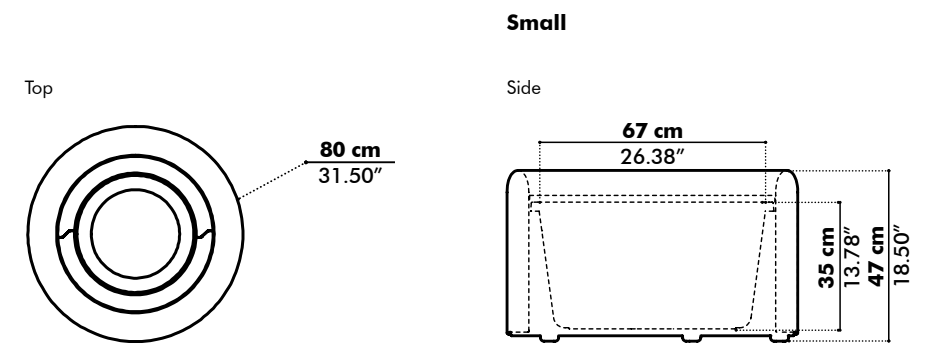



Finishes

Filling: Acoustic foam + Plywood, MDF
 Extra layer in fabric collections CAT A, B, C, D, E, possible
 Baseplate: Black MDF with plastic feet
 (check our application overview p. 330)

Acoustics

Acoustic Principles

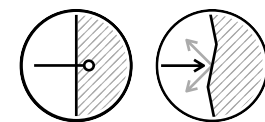

Absorption Diffusion

Acoustic Performance



Low Tones Mid Tones High Tones

How to order

model, size (S|M|L), Fabric (CAT > collection > color)



BuzziPleat

— by 13&9 Design

A series of architectural solutions by 13&9

The BuzziPleat delivers light and sound control with architectural edge. This series reinterprets ancient techniques used in fashion design, like smocking and pleating, to create large-scale, yet lightweight sculptural forms, made of sound-absorbing BuzziFelt.

Architectural folds maximize surface area, delivering exceptional acoustic performance. The hanging acoustic pendants can be configured with or without a light source, to marry sound control and illumination in one multi-purpose product.

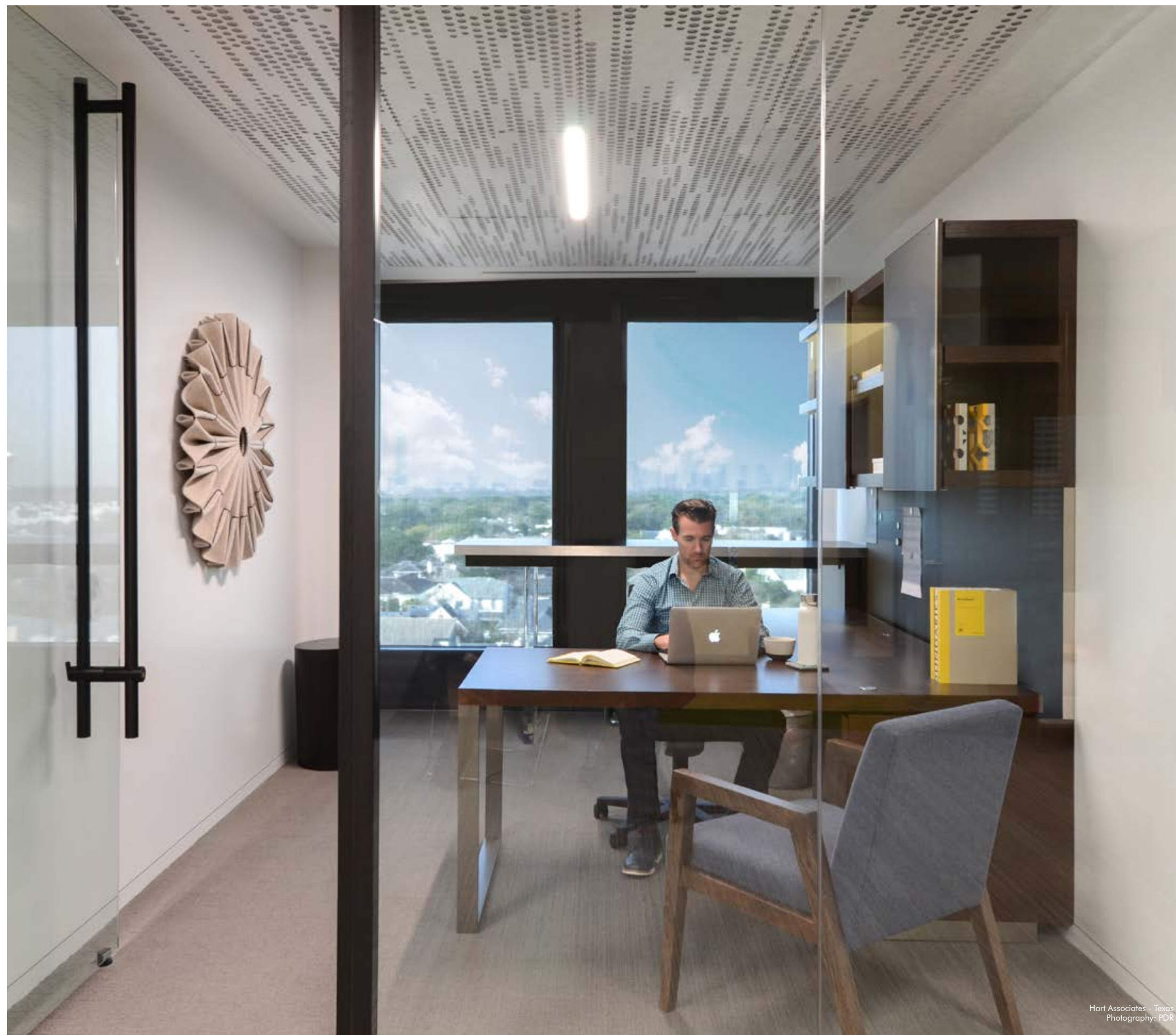

Models

Ripple M

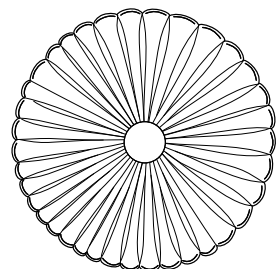
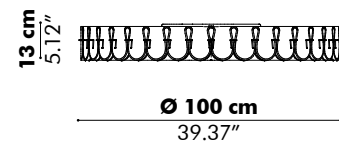

Ripple L

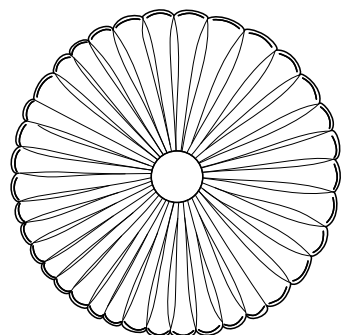
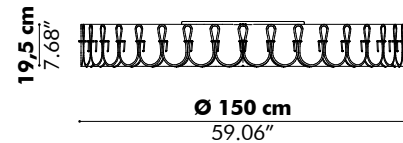

Edel M

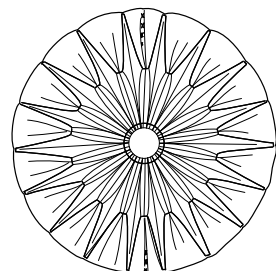
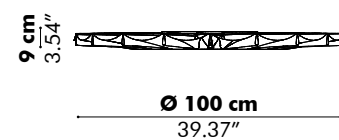

Edel L

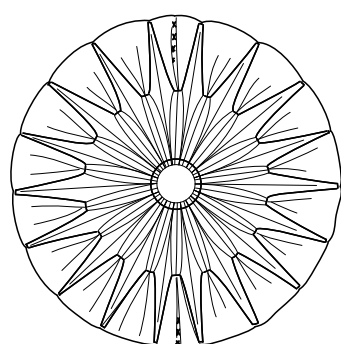
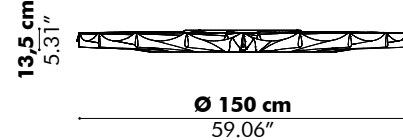

Finishes

Pleat in BuzziFelt: OffWhite, StoneGrey, Lime, Anthracite
 Extra layer of fabric (CAT A) possible on BuzziFelt OffWhite or Anthracite (check our application overview p. 330)
 Lace in OffWhite or Black

Mounting

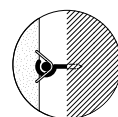

Wall Mounted (only for Edel)
 Fixing System Wall
 Central wooden support in ash white wash or ash black stained
 excl. mounting hook

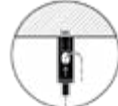

Ceiling Suspended
 Fixing System Screw with 3 cables of 2 m - 78.74" or
 5 m - 196.85" (black or alu)

Acoustics

Acoustic Principles

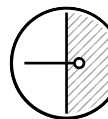

Absorption

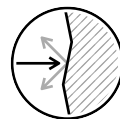

Diffusion

Acoustic Performance



Mid Tones



High Tones

How to order

Size
 Model
 Mounting System
 Color lace



BuzziScreen

— by Sas Adriaenssens

Sound-absorbing dividing screen

The folding screen has come back into fashion with a bang! The BuzziScreen is a contemporary take on the flexible room divider with all sorts of advantages. For example, it can be extended infinitely: the handy recycled zipper system makes it easy for you to add panels. Just like with other BuzziSpace products, you can pin objects, photos or letters to the screen, and of course it works as sound absorption as well. Divide your office or room however you want, wherever you want!



Volkswagen Financial IT offices - Berlin
Photography: Andrea Janssen

Dimensions

	Height	Zipper Height
S	120 cm 47.24"	100 cm 39.37"
M	150 cm 59.06"	130 cm 51.18"
L	200 cm 78.74"	180 cm 70.87"

BuzziScreen

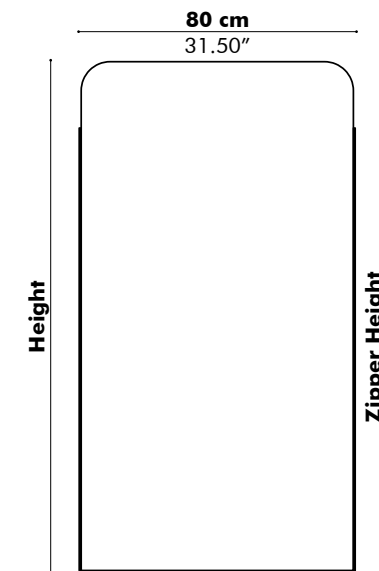

BuzziFoot (optional)

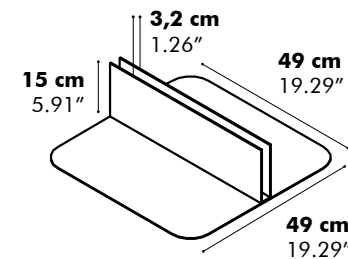

Panels

puller side



pin side



1 - Stop panel

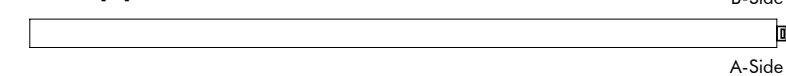

2 - Start panel

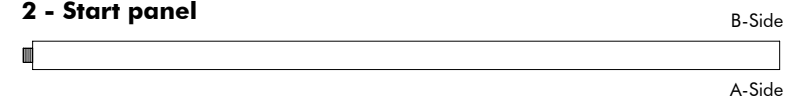

3 - Mid panel

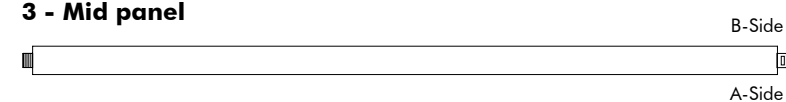

4 - Stop extra panel

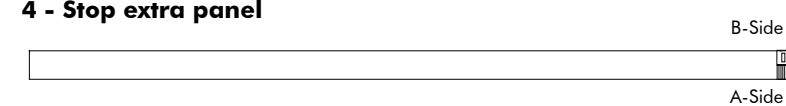

Finishes

Cover in BuzziFelt
Available in BuzziFelt Printed
Extra layer in fabric collections CAT A, B, C, D, E, F possible (check our application overview p. 330)
Zipper in orange or black

Mounting

It's not recommended to put several BuzziScreens in one straight line (go zigzag!)

Options

Bicolor
BuzziFoot - alu color (RAL 9006) or black (RAL 9005)

Acoustics

Acoustic Principles

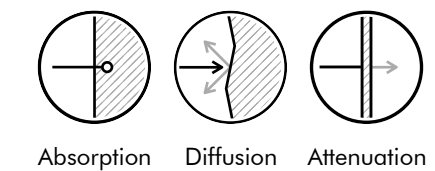

Acoustic Performance

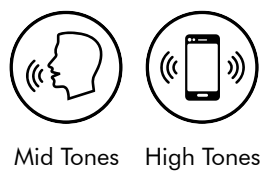

How to order

Size
Model panel
Fabric (CAT > collection > color)
Color zipper
Options

5 - Start extra panel

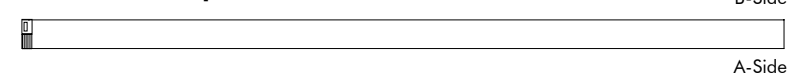

6 - Mid extra R panel

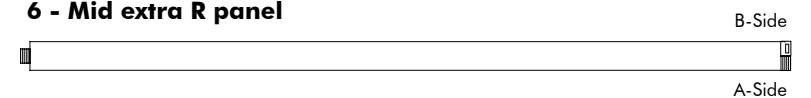

7 - Mid extra L panel

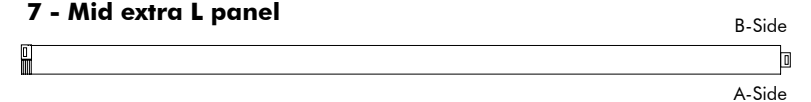

8 - Mid extra plus panel

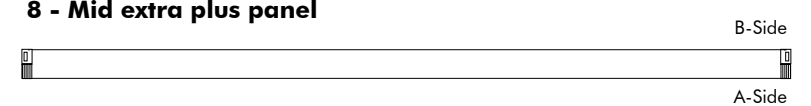

BuzziScreen Mix

— by Sas Adriaenssens

Sound-absorbing sound screen with different heights

The BuzziScreen Mix combines different heights and fabrics to vibrant effect. Alongside, the regular BuzziSpace fabrics (and select collections by Kvadrat) give a great edge to the end result. Add industrial zippers and this is not your average room divider, but a true designer piece. Of course, this room divider wouldn't be BuzziSpace if it didn't have acoustic qualities.



Dimensions

	Height	Zipper height
S	120 cm 47.24"	110 cm 43.31"
M	150 cm 62.99"	110 cm 43.31"
L	200 cm 78.74"	110 cm 43.31"

BuzziScreen Mix

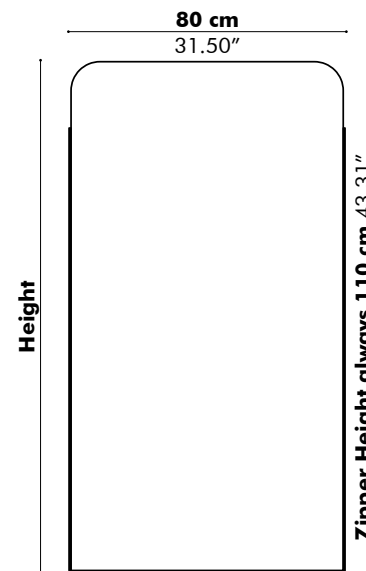

BuzziFoot (optional)

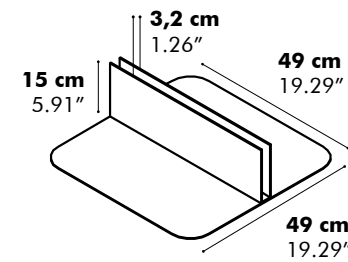

Panels

puller side



pin side



1 - Stop panel

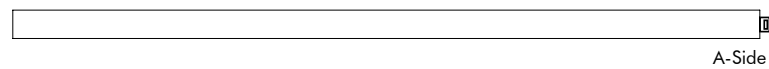

2 - Start panel

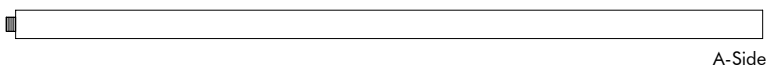

3 - Mid panel

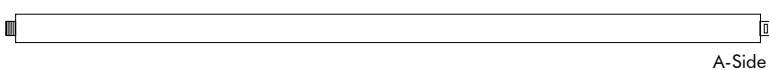

4 - Stop extra panel

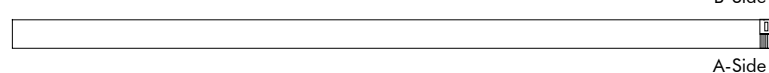

Finishes

Cover in BuzziFelt
Available in BuzziFelt Printed
Extra layer in fabric collections CAT A, B, C, D, E, F possible (check our application overview p. 330)
Zipper in orange or black

Mounting

It's not recommended to put several BuzziScreens in one straight line (go zigzag!)
It's not recommended to combine panel S with L next to each other

Options

Bicolor
BuzziFoot - alu color (RAL 9006) or black (RAL 9005)

Acoustics

Acoustic Principles

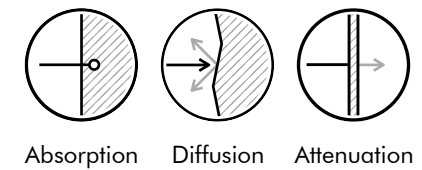

Acoustic Performance

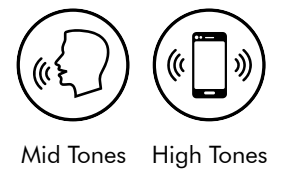

How to order

Size
Model panel
Fabric (CAT > collection > color)
Color zipper
Options

5 - Start extra panel

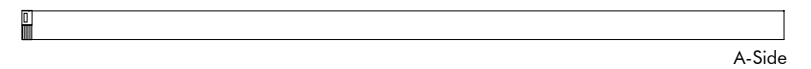

6 - Mid extra R panel

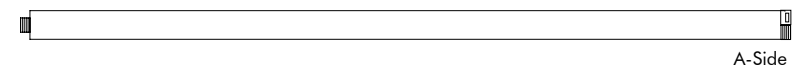

7 - Mid extra L panel

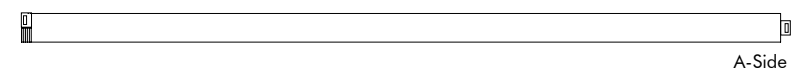

8 - Mid extra plus panel

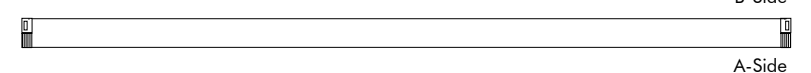



BuzziShield Desk

— by BuzziSpace Studio

Create private workstations

BuzziShield Desk is a voluminous desk partition that instantly creates private and snug workstations all while absorbing noise and adding visual privacy so focus work can be done. The lightweight and flexible acoustic solution features a thick upholstered body (7 cm/2.8") that's sturdy enough to sit on top of a desk by placing it on its metal feet or secure the acoustic solution to the edge of a desk with its unobtrusive fixes. Combine more than one BuzziShield Desk to define multiple workstations, or use them individually.



Dimensions

Panel

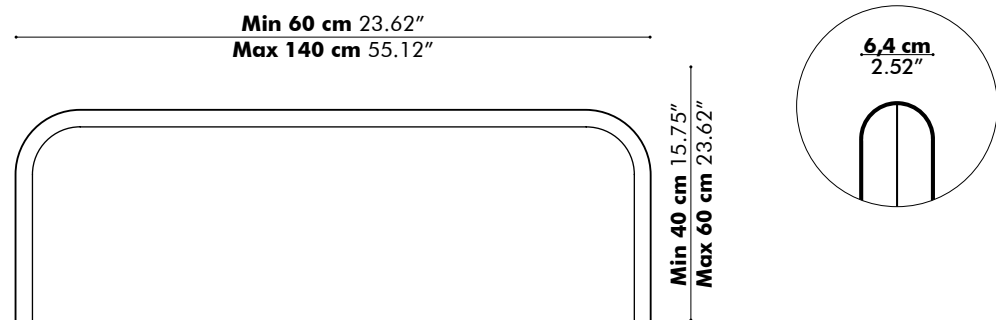

BuzziFix

Fix Foot

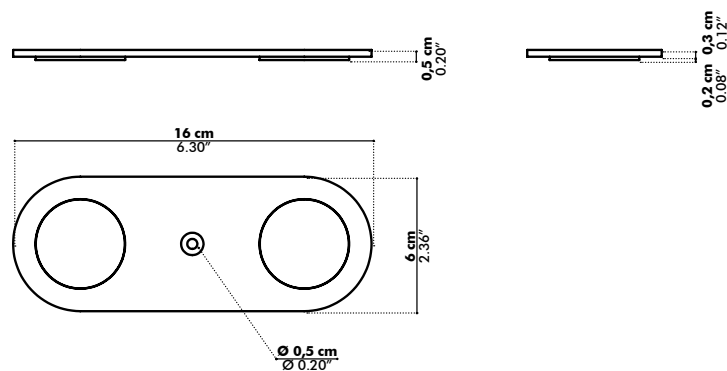

Fix L

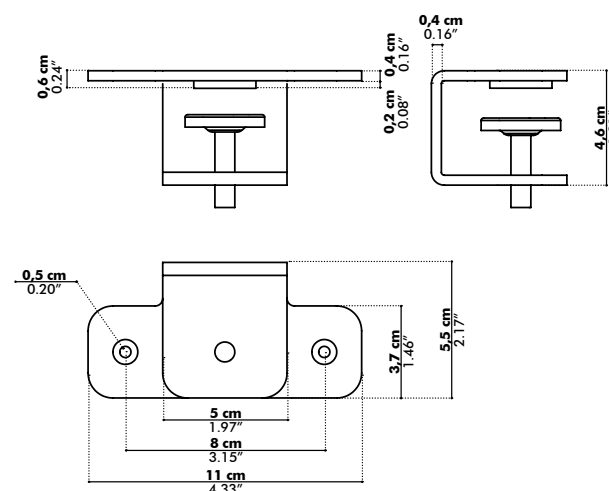

Fix L-Plus

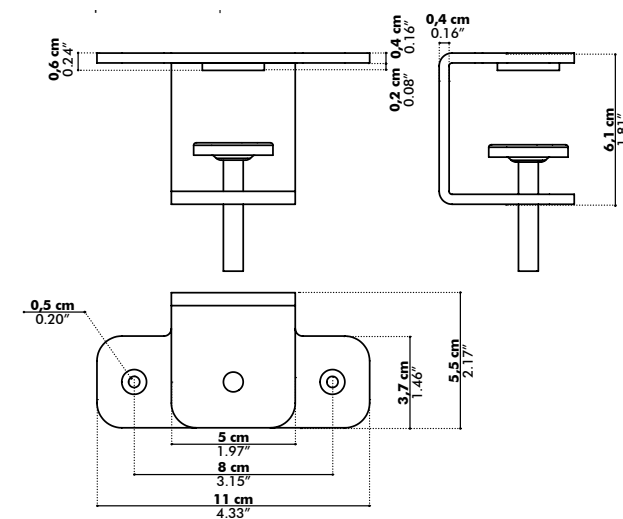

Fix XL

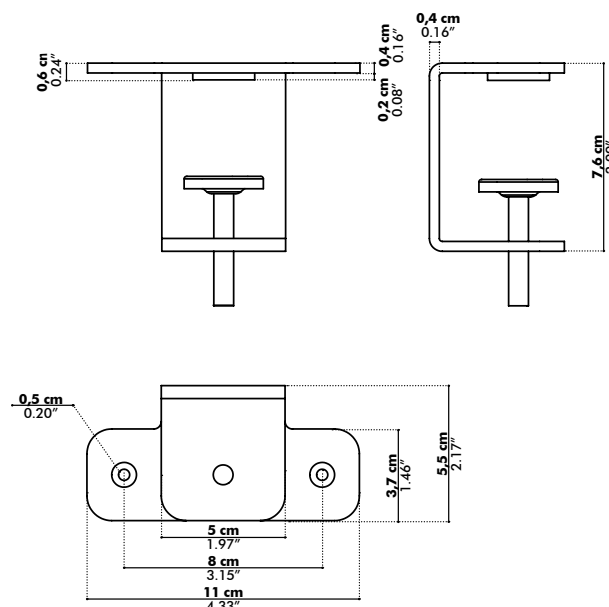

Finishes

Upholstered acoustic foam element
 Fix | Foot: powder coated metal in black (RAL 9005)
 Fabrics: Fabric, Trevira CS|CS+, Revive 1, Velvet, Clara 2, Remix 3, Hero, Tonus 4, Memory 2 (check our application overview p. 330)

Mounting

Foot
 Fix L - worktop thickness 12 > 27mm | 0.47" > 1.06"
 Fix L-Plus - worktop thickness 18 > 43mm | 0.71" > 1.69"
 Fix XL - worktop thickness 28 > 57mm | 1.10" > 2.24"

Acoustics

Acoustic Principles

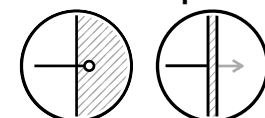

Absorption Attenuation

Acoustic Performance



Low Tones Mid Tones High Tones

How to order

Size (WxH), Fabric (CAT > collection > color), type of fix

Need help? Contact BuzziSpace Project Care
project.care@buzzi.space



BuzziShield Free

— by BuzziSpace Studio

A cozy office divider

BuzziShield Free is unlike your usual room and office dividers and won't create a cold atmosphere as its glass or plastic counterparts do. Due to its voluminous upholstered body, this cozy office divider effectively absorbs sound while adding a colorful element into any workspace. The lightweight and adaptable BuzziShield Free works well on its own as a partition between desks to create private workstations for both seated and standing desks. Or combine more than one to introduce natural flows in an open space. Additionally, BuzziShield Free can also work in conjunction with BuzziShield Hook and BuzziShield Desk for that ultimate soft architecture look.



Models

BuzziShield Free Medium

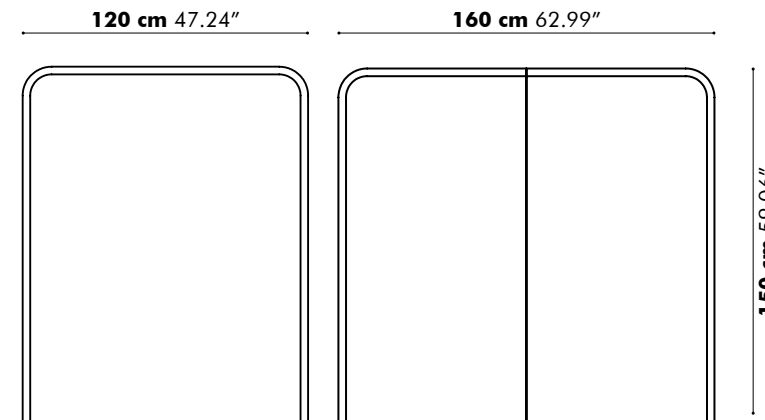

BuzziShield Free High

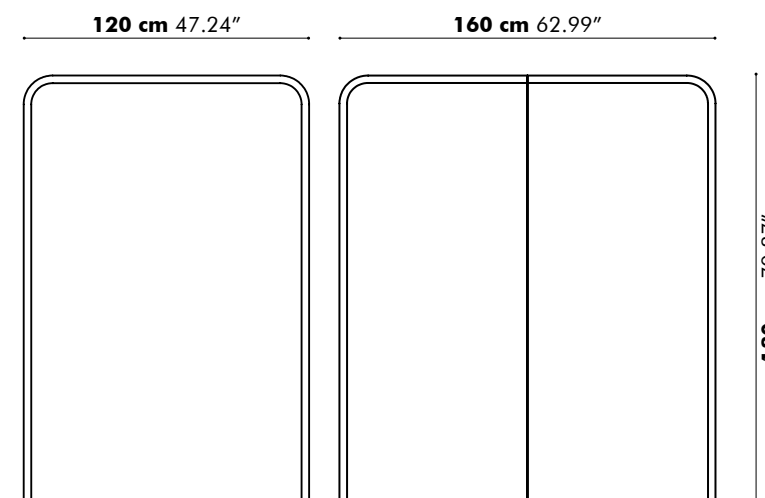

Finishes

Upholstered acoustic foam element
 2 baseplates included in powder coated black metal (RAL 9005)
 Cover: Fabric, Trevira CS+ | CS, Revive 1, Velvet, Clara 2, Remix 3, Hero, Tonus 4, Memory 2 (check our application overview p. 330)

Acoustics

Acoustic Principles

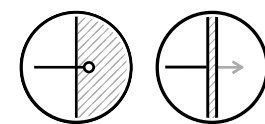

Absorption Attenuation

Acoustic Performance



Low Tones Mid Tones High Tones

How to order

Size (H x W), fabric (CAT > Collection > color)



BuzziShield Hook

— By BuzziSpace Studio

Create snug environments without building walls

BuzziShield Hook is unlike your usual desk partitions and office dividers and won't create a cold atmosphere as its glass or plastic counterparts do. The lightweight and flexible acoustic solution not only helps to mitigate sound but also adds an unexpected design element within any workspace due to its 7cm /2.8" thick upholstered body and elegant curve. Combine more than one BuzziShield Hook to create snug areas for focus work, meetings, or collaborations to occur without having to build walls or partition it between desks to create private workstations.





Dimensions

BuzziShield Hook Flat

BuzziShield Hook Flat Medium Left

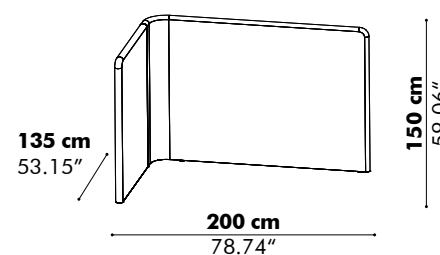

BuzziShield Hook Flat High Left

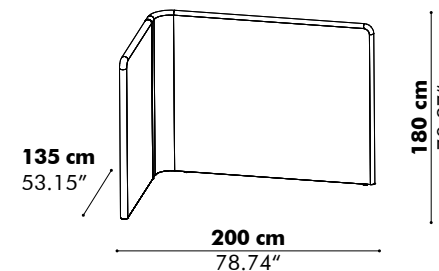

BuzziShield Hook Flat Medium Right

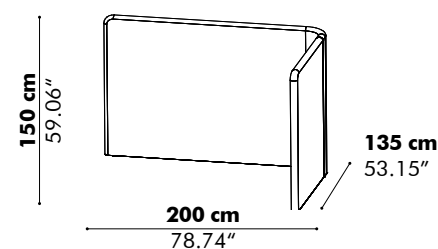

BuzziShield Hook Flat High Right

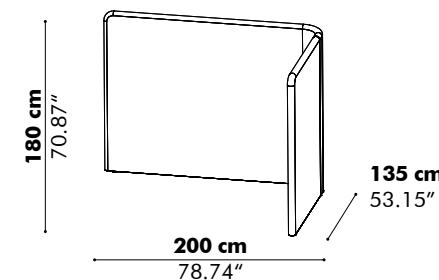

BuzziShield Hook Wedge

BuzziShield Hook Wedge Medium Left

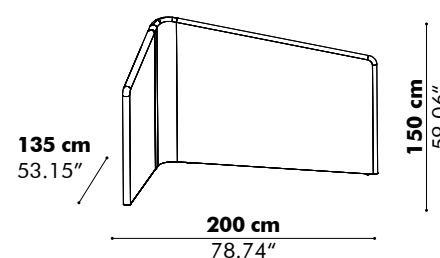

BuzziShield Hook Wedge High Left

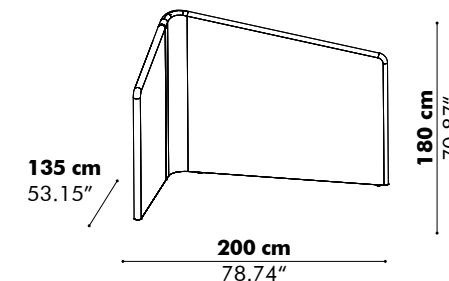

BuzziShield Hook Wedge Medium Right

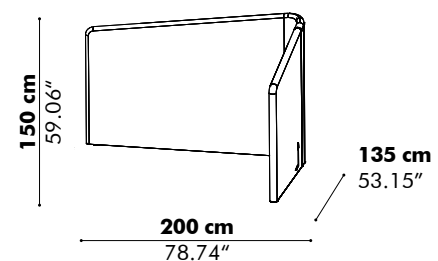

BuzziShield Hook Wedge High Right

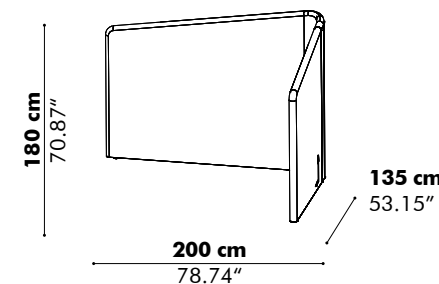

Finishes

Upholstery in fabric collections CAT A, B, C, D, E (check our application overview p. 330)

Acoustics

Acoustic Principles

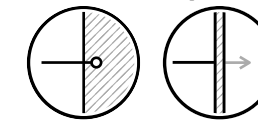

Absorption Attenuation

Acoustic Performance



Low Tones Mid Tones High Tones

How to order

Model, orientation, size, fabric (CAT > collection > color)

Need help? Contact BuzziSpace Project Care project.care@buzzi.space

BuzziSkin

— by Sas Adriaenssens

Felt with self-adhesive backing

What would your perfect wall be like? Cuddly and sound-absorbing? A surface you can pin photos to? Available in striking colors and easy to install? Environmentally friendly? Now you can have all these things at once! BuzziSkin has everything it takes to improve any interior at home or at work. It is available on handy, self-adhesive rolls.

Roll

Roll

10 m x 0,98 m 32.81 ft x 38.58"

6,1 mm 0.24"

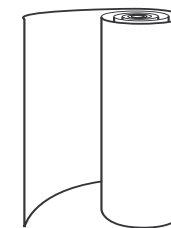

Finishes

Layer of BuzziFelt with self-adhesive backing

Mounting

Wall mounted
Self-adhesive backing
Not recommended for ceiling or floor applications

Acoustics

Acoustic Principles

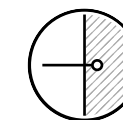

Absorption

Acoustic Performance



Mid Tones



High Tones

How to order

BuzziFelt color

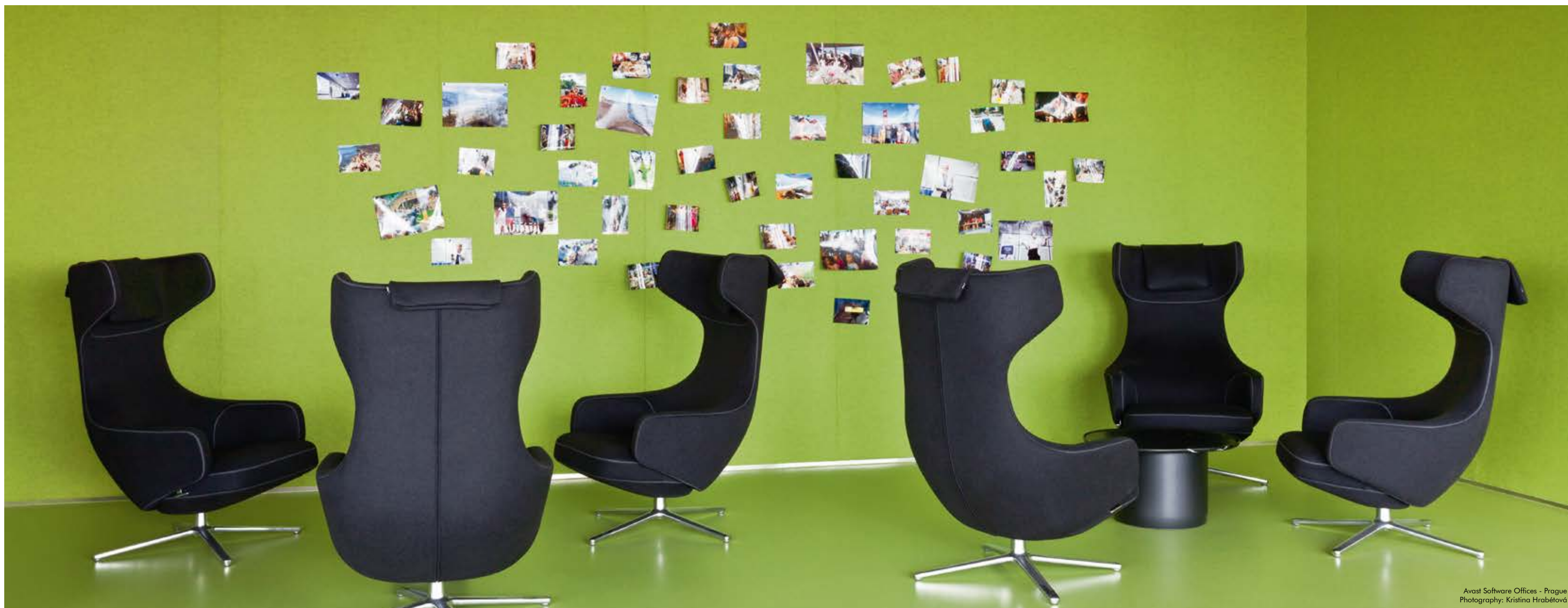



BuzziSkin Cuts

— by Sas Adriaenssens

Felt shapes with self-adhesive backing

Add more punch to your wall or surface with BuzziSkin Cuts and create a little piece of art with the different shapes in striking colors.

Models

Round

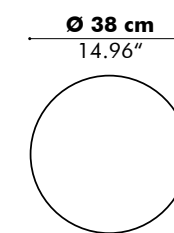

Square

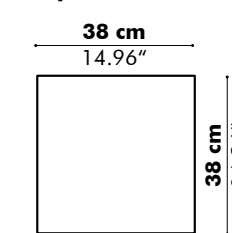

Penta

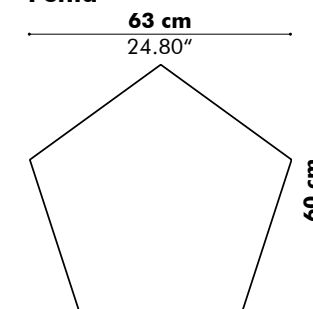

Hexa

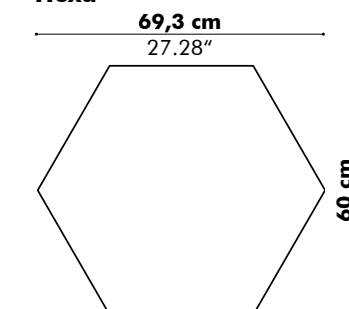

Plank

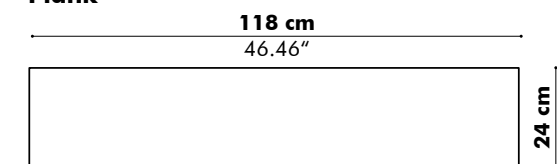

Always in set of 12 pieces

Finishes

Layer of BuzziFelt with self-adhesive backing

Mounting

Wall mounted
Self-adhesive backing
Not recommended for ceiling or horizontal applications

Acoustics

Acoustic Principles

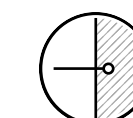

Absorption

Acoustic Performance



Mid Tones



High Tones

How to order

Model
BuzziFelt color

BuzziSkin Printed

— by Sas Adriaenssens

Cheer up your walls with sound-absorbing wall cover

Customize your wall with BuzziSkin Printed and enhance the room acoustics at the same time. Made from sound-absorbing materials, this bold wall cover helps reduce high tones in a space, e.g., ringtones and typing sounds. The self-adhesive backing makes installation very easy while the tackable surface offers the possibility to personalize a space with notes and images. Easily brighten up corners and nooks with a pinch of creativity no matter the print you choose. Go with the marble print for a sophisticated look, the concrete for a more urban vibe or go wild with one of the green or camouflage prints—any of these will undoubtedly make your interior stand out!

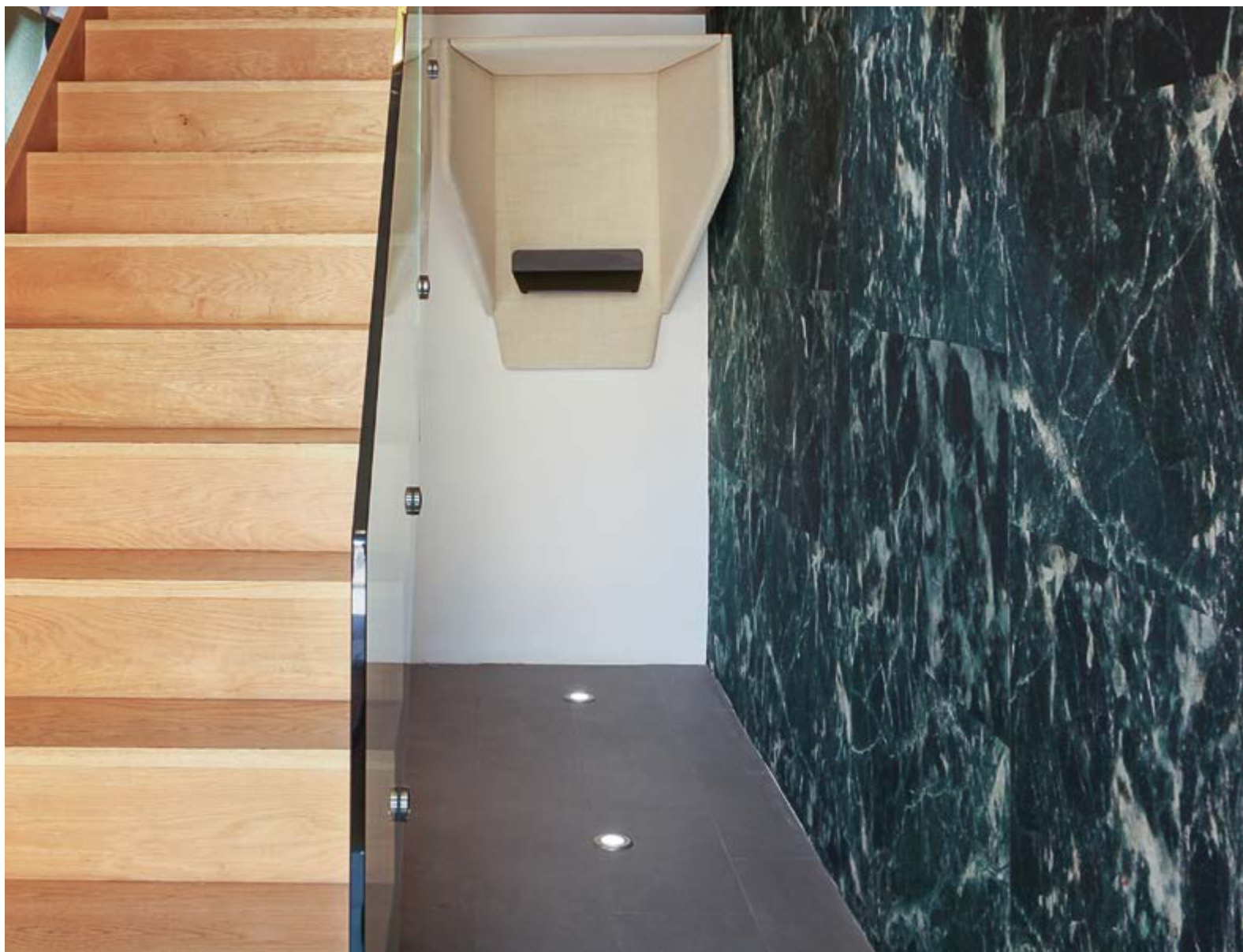

Roll

Roll

10 m x 0,98 m 32.81 ft x 38.58"

6,1 mm 0.24"



Material

Front: BuzziSkin Printed
Back: Self-adhesive

Mounting

Wall mounted
Self-adhesive backing
Not recommended for ceiling or floor applications

Acoustics

Acoustic Principles

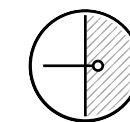

Absorption

Acoustic Performance



Mid Tones



High Tones

Prints



Marble Emperor



Marble Absynth



Jungle

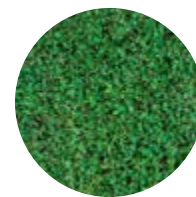

Green 1



Green 2



Concrete



Camo Amazon



Camo Desert



Camo Snow



Camo Taiga

Print is only on the front of the felt. The visible edges will still have the original OffWhite color.

How to order

Print

BuzziTab Soft

— by BuzziSpace Studio

A chic reinterpretation of the classic acoustic panel
 BuzziTab Soft is a playful acoustic treatment with exceptional sound-absorption capabilities. This chubby wall solution reinterprets the classic acoustic panel, suggesting that acoustics and design do pair. With its friendly appearance, well-rounded corners and edges, BuzziTab Soft breaks the hard surfaces and lines of a space. It lightens and softens walls—all while providing a retro look and feel. Play with perspectives and add depth of field with different models, available in various sizes and depths, and choose your favorite color combinations for a distinctive interior.



Models

Square

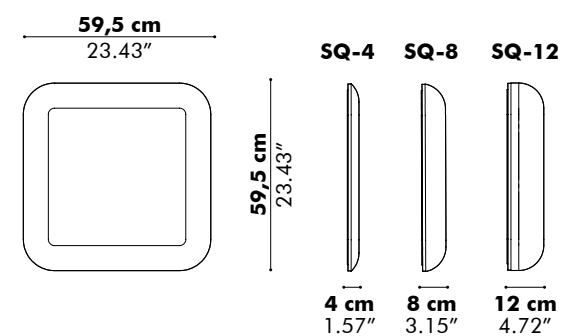

Rectangular

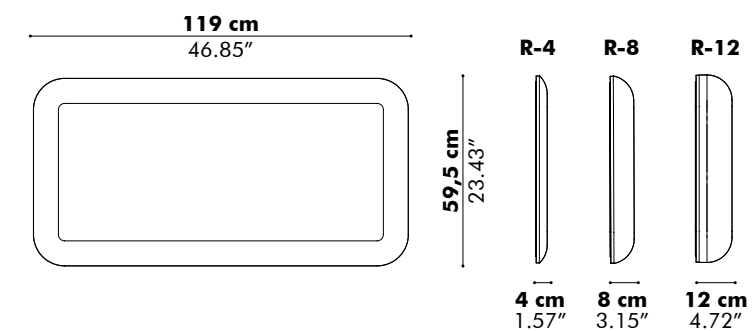

Finishes

Upholstery in CAT A, B, C, D, E, F (check our application overview p. 330)

Mounting

BuzziTab Soft Fixing System included.
 (horizontal or vertical mounting)

Acoustics

Acoustic Principles

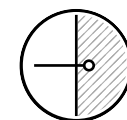

Absorption

Acoustic Performance



Low Tones



Mid Tones



High Tones

How to order

Model
 Fabric (CAT > collection > color)



BuzziTile Flat

— by Sas Adriaenssens

Sound-absorbing flat wall tile

BuzziTile Flat is more than an acoustical wall tile. Create unique and exciting wall features by combining different shapes and colors for an incomparable effect.



Models

Square L

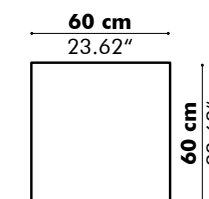

Square XL

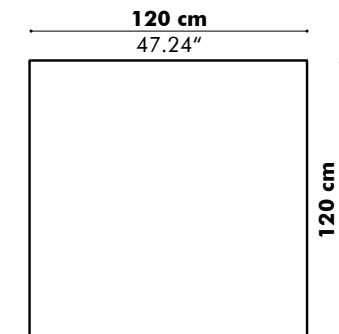

Metro

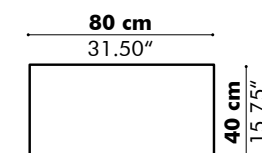

Triangle

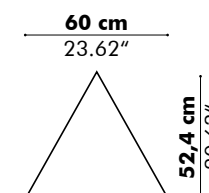

Triangle XL

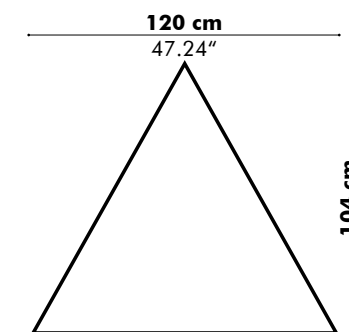

Thickness

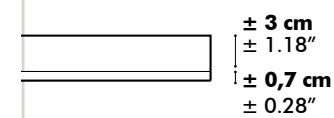

Finishes

Upholstery in fabric collections CAT A, B, C, D, E, F (check our application overview p. 330)
Back always in wood, without stitch

Mounting

Self-adhesive tape or power magnets
Not recommended for ceiling applications

Acoustics

Acoustic Principles

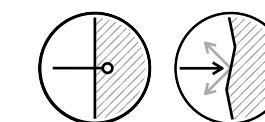

Absorption Diffusion

Acoustic Performance

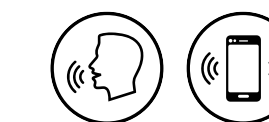

Mid Tones High Tones

How to order

Model
Fabric (CAT > collection > color)
Mounting option



BuzziTile 3D

— by Sas Adriaenssens

Sound-absorbing wall tile

The BuzziTile 3D turns any wall into a must-see! Combine shapes and colors for an incomparable effect thanks to the tiles' architectonic touch. The complete BuzziTile family is a perfect solution for balancing sound.



Models & Patterns

Square L

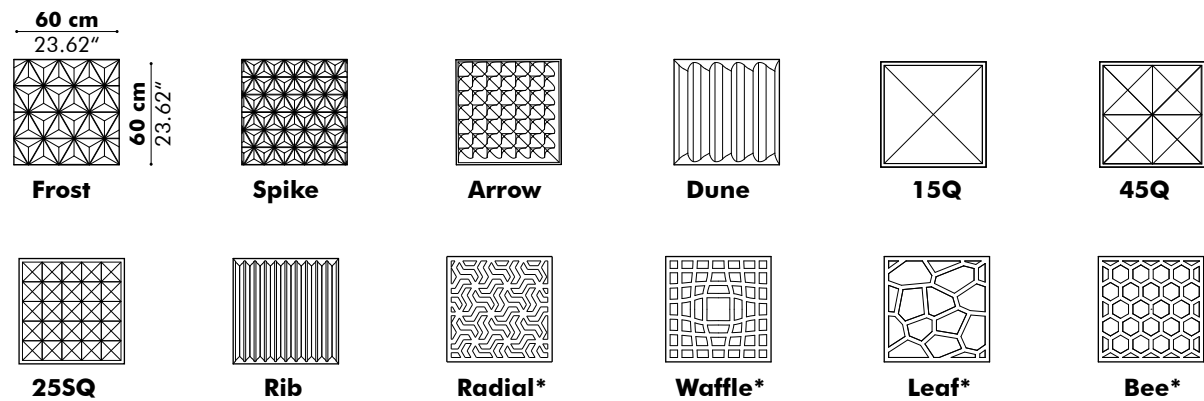

Square XL

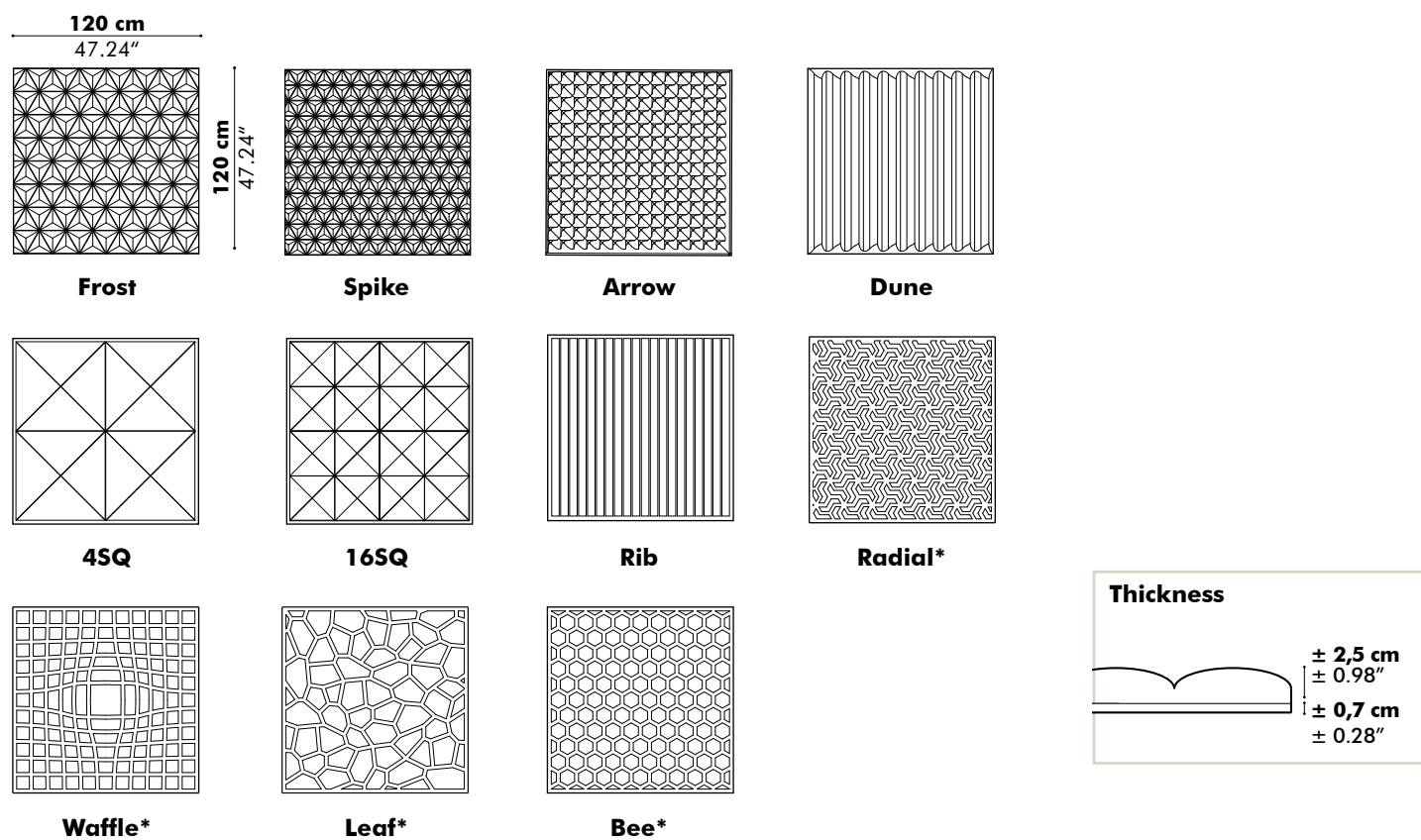

Hexa

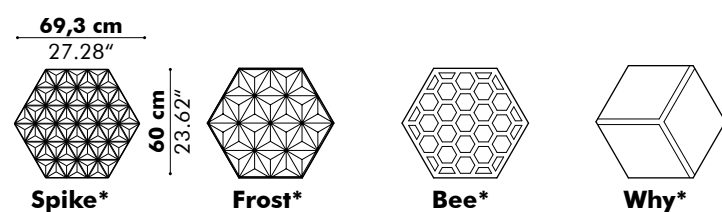

Penta

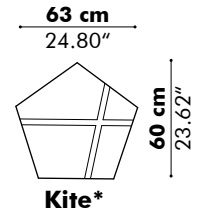

Metro

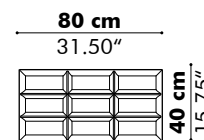

Triangle Spike*

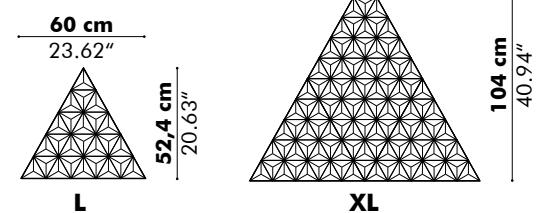

Finishes

Upholstery in fabric collections CAT A, B, C, D, E, F (check our application overview p. 330)
Back in felt, with or without stitch (*stitch not possible)
Back in wood, no stitch

Mounting

Self-adhesive tape or power magnets
Not recommended for ceiling applications
Back in felt: self-adhesive tape
Back in wood: self-adhesive tape or power magnets

Acoustics

Acoustic Principles

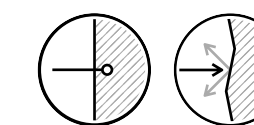

Absorption Diffusion

Acoustic Performance

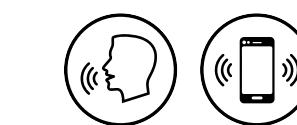

Mid Tones High Tones

How to order

Model
Pattern
Back
Stitch
Mounting option
Fabric (CAT > collection > color)





BuzziTotem

— by BuzziSpace Studio

Sculptural, freestanding acoustic pillar

Say hello to this playful, freestanding acoustic pillar, available in three models and a range of 3D statement patterns. No matter the model, the soft edges help diffuse sounds while the upholstered acoustic foam body absorbs sound in its entirety. Needless to say, BuzziTotem is one of our peak acoustic performance solutions. Easily fit this standing, architectural element into corners to trap sound waves in offices, residential settings, or hospitality areas.



Models

Wedge

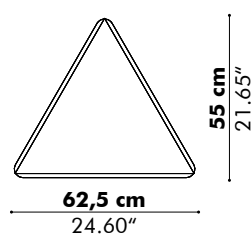

Height

S	120 cm	47.24"
M	155 cm	61.02"
L	190 cm	74.80"

Cylinder

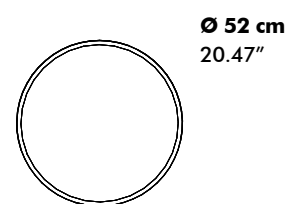

Beam

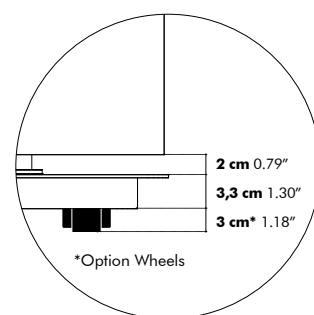
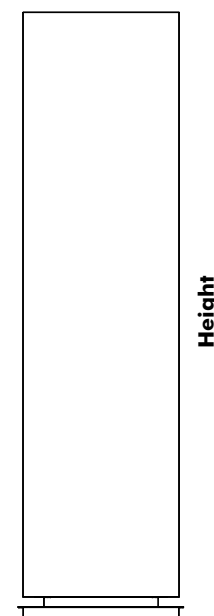
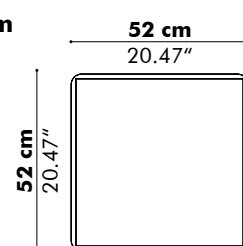

Finishes

Upholstery in fabric collections CAT A, B, C, D, E, F
 (check our application overview p. 330)
 Baseplate in black (RAL 9005)

Options

Wheels (height + 3cm - 1.18")

Acoustics

Acoustic Principles

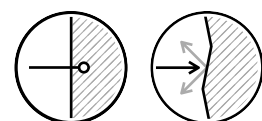

Absorption Diffusion

Acoustic Performance



Low Tones Mid Tones High Tones

How to order

Model
 Flat or 3D pattern
 Height
 Fabric (CAT > collection > color)
 Bottom
 Option



Models

Wedge

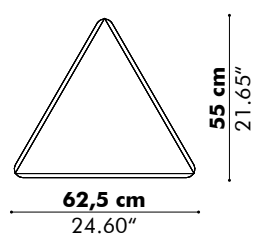

Cylinder

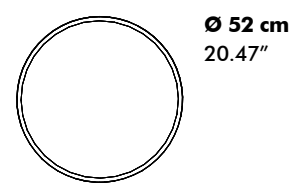

Beam

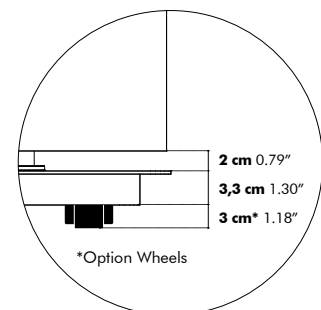
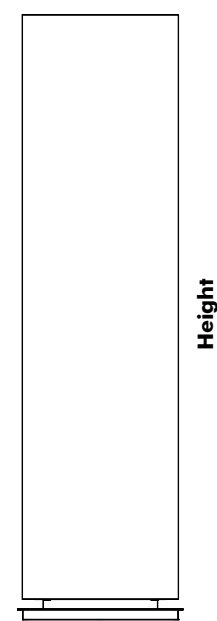
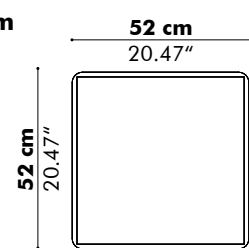

Height

- S** 120 cm 47.24"
- M** 155 cm 61.02"
- L** 190 cm 74.80"

Cylinder



Flat

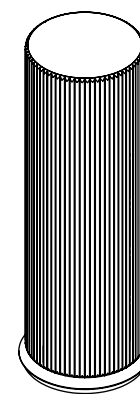

3D Rib Thin

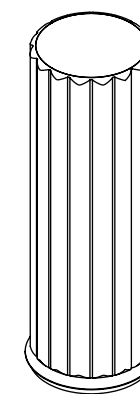

3D Rib Thick

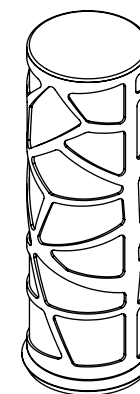

3D Leaf

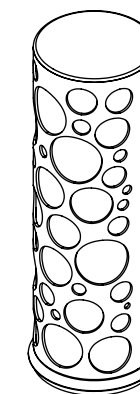

3D Bubble

Wedge

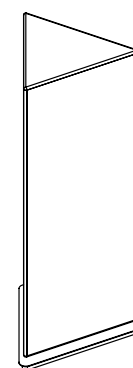

Flat

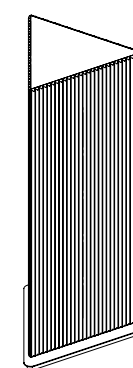

3D Rib Thin

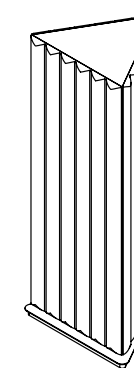

3D Rib Thick



3D Tri

Patterns

Beam

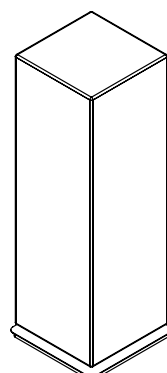

Flat

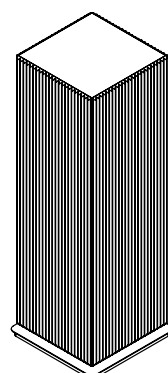

3D Rib Thin

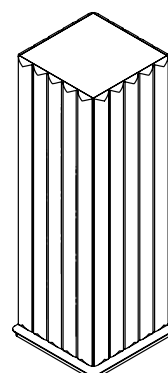

3D Rib Thick

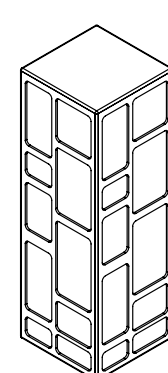

3D Frame



BuzziTripl Desk

— by BuzziSpace Studio

A simple and private desk solution

Create your own cocoon with this straightforward design and noise-absorbing desk partition made of three layers of felt. The flexible solution is easy to install and can be used individually or placed with several others to define multiple workstations. Choose the color and shape that best matches your needs and décor.

Dimensions

BuzziTripl Round corners

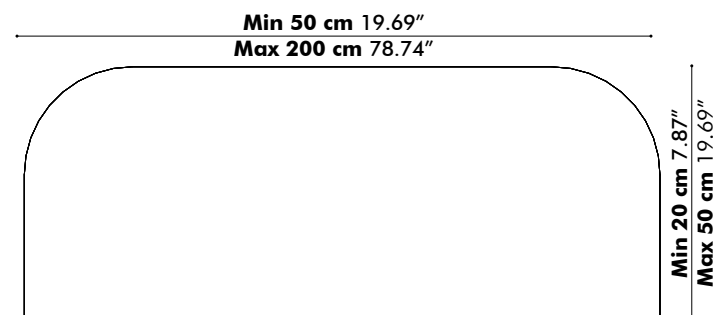

BuzziTripl Wedge

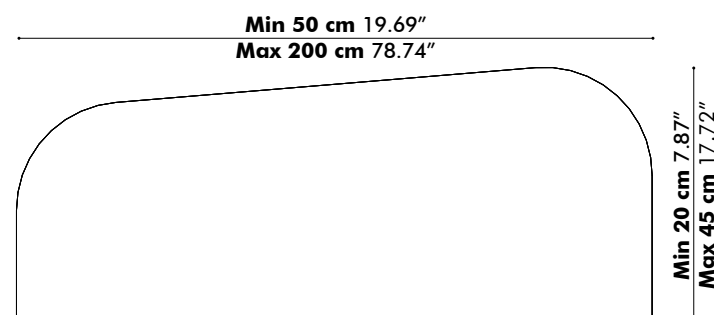

BuzziTripl Fix (included)

Metal Thickness 0,3 cm | 0.12"

Y L

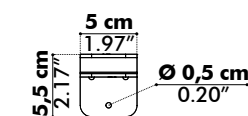

Y L-Plus

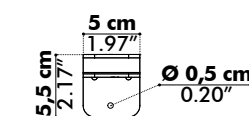

Y XL

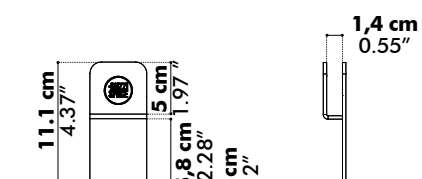
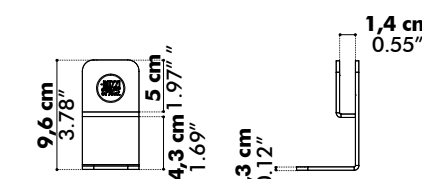
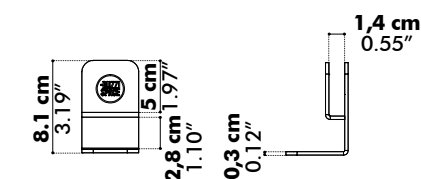
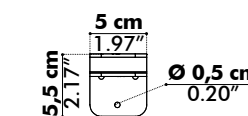

223 g/pc | 0.49 lbs/pc

239 g/pc | 0.53 lbs/pc

257 g/pc | 0.57 lbs/pc

Foot

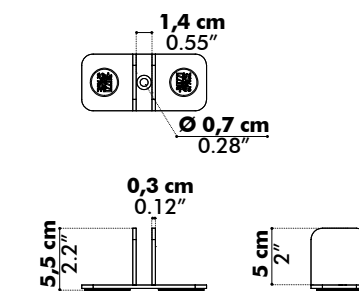

244 g/pc | 0.54 lbs/pc

Finishes

3 layers of felt: 2 layers of BuzziFelt with furniture felt core
Round corners or wedge | Fix in black (RAL 9005) or white (RAL 9010)

Options

Connections part

X

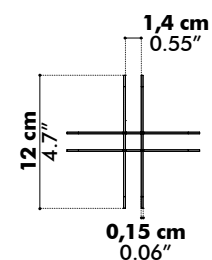

H

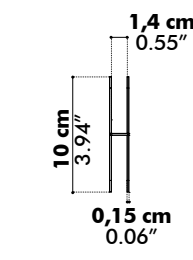

Acoustics

Acoustic Principles

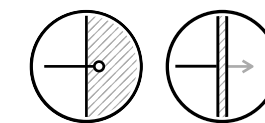

Absorption Attenuation

Acoustic Performance

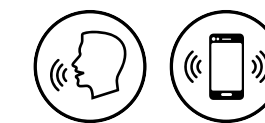

Mid Tones High Tones

How to order

Size (W x H),
BuzziFelt* color,
Round corners or wedge
Type of fix
Color of fixes
Option

*Not available in Ecobrown 58



BuzziTripl Desk Split

— by BuzziSpace Studio

A simple desk divider

A simple desk partition that easily divides any communal table or desk into two workstations. Made from three layers of felt, BuzziTripl Desk Split helps to reduce noise so employees can concentrate and focus at work. Combine it with BuzziTripl Desk in various depths and heights to achieve a nesting feeling. Choose the color and shape that best matches your needs and décor.



Models

Wedge

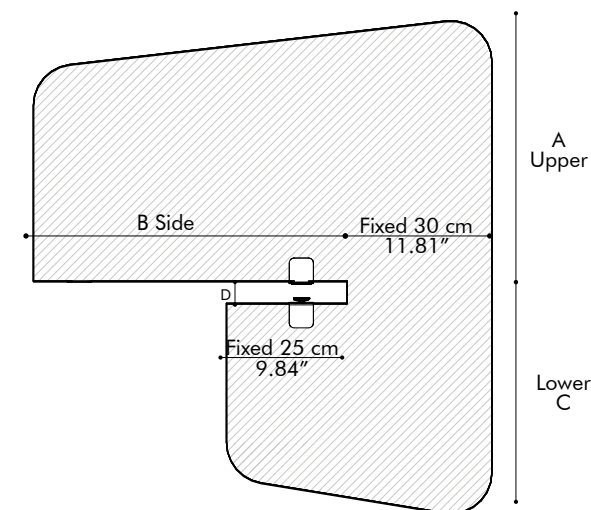

Round Corners

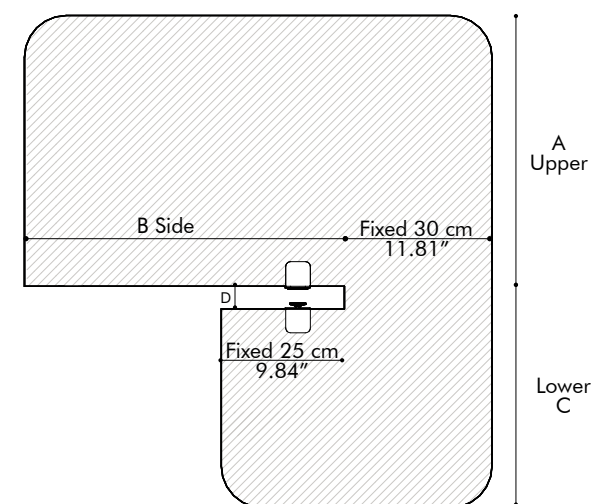

	A	B	C
S	40 cm 15.75"	45 cm 17.72"	25 cm 9.84"
		65 cm 25.59"	45 cm 17.72"
			25 cm 9.84"
M	45 cm 17.72"	45 cm 17.72"	45 cm 17.72"
		65 cm 25.59"	25 cm 9.84"
			45 cm 17.72"
L	50 cm 19.69"	45 cm 17.72"	25 cm 9.84"
		65 cm 25.59"	45 cm 17.72"
			25 cm 9.84"
XL	55 cm 21.65"	45 cm 17.72"	25 cm 9.84"
		65 cm 25.59"	45 cm 17.72"
			25 cm 9.84"

Worktop Thickness	D	
12 > 28 mm 0.47" > 1.10"	4,1 cm 1.61"	Fix included
29 > 42 mm 1.14" > 1.65"	5,7 cm 2.24"	Fix included
43 > 56 mm 1.69" > 2.20"	7,1 cm 2.80"	Fix included

Finishes

3 layers of felt: 2 layers of BuzziFelt with furniture felt core | Round corners or wedge.

Fixes in black (RAL 9005) or white (RAL 9010)

Fixes

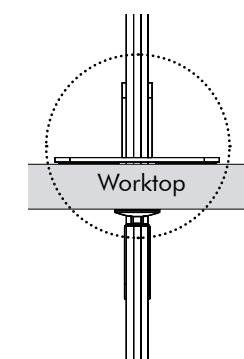

Two antiskid pads underneath the fix

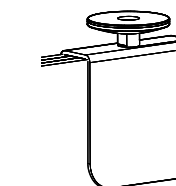
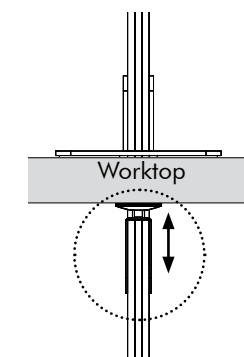
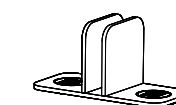

Acoustics

Acoustic Principles

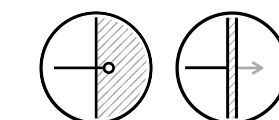

Absorption Attenuation

Acoustic Performance



Mid Tones High Tones

How to order

- Size (A,B,C)
- BuzziFelt* color
- Round corners or wedge
- Color of fixes
- Worktop thickness
- Round corners or wedge

*Not available in Ecobrown 58

BuzziTripl Home

— by BuzziSpace Studio

Work from home cocoon

BuzziTripl Home is a free-standing desk and room partition, made of three layers of felt, that can be used in conjunction (or separately) to create a temporary office at home. Specially designed with today's compact homes in mind, both BuzziTripl Home Low and BuzziTripl Home High are foldable and lightweight, making for convenient storage, whether it be in the closet or under a bed.

Dimensions

BuzziTripl Home Low

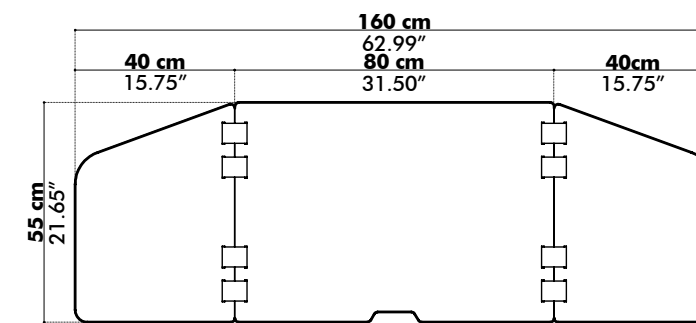

BuzziTripl Home High

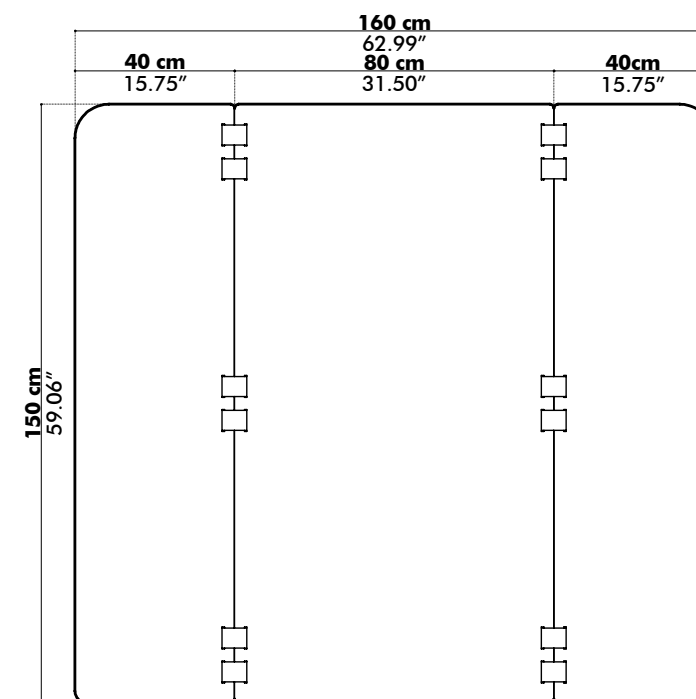

Finishes

3 layers of felt: 1 layer of BuzziFelt OffWhite, 1 layer of BuzziFelt Antracite, furniture felt core

Acoustics

Acoustic Principles

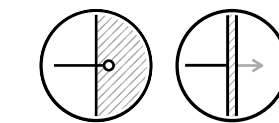

Absorption Attenuation

Acoustic Performance



Mid Tones High Tones

How to order

Model



BuzziTripl Wrap Desk

— by BuzziSpace Studio

A sound-absorbing working nest

For those looking to create private workstations, BuzziTripl Wrap Desk delivers sound-absorbing features while providing a cocoon-like area for focus work to happen. Even visual distractions can be kept out of the spotlight. This versatile office desk partition was created to meet the need for privacy and concentration, without having to sacrifice personal space.



Dimensions

BuzziTripl Wrap Desk Full

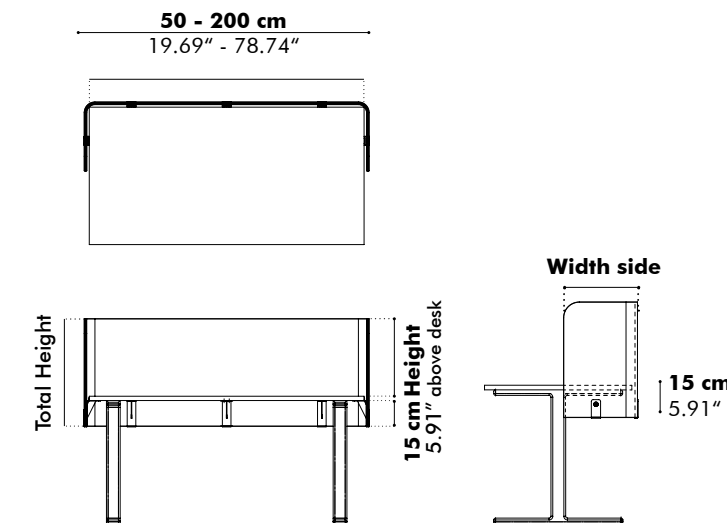

BuzziTripl Wrap Desk Left

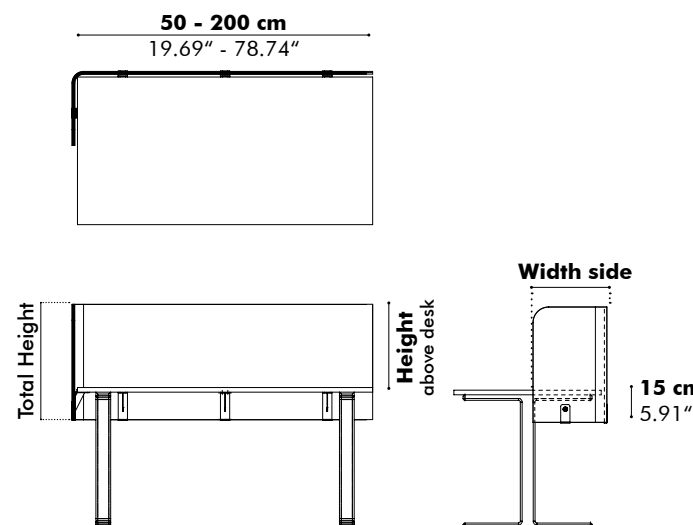

BuzziTripl Wrap Desk Right

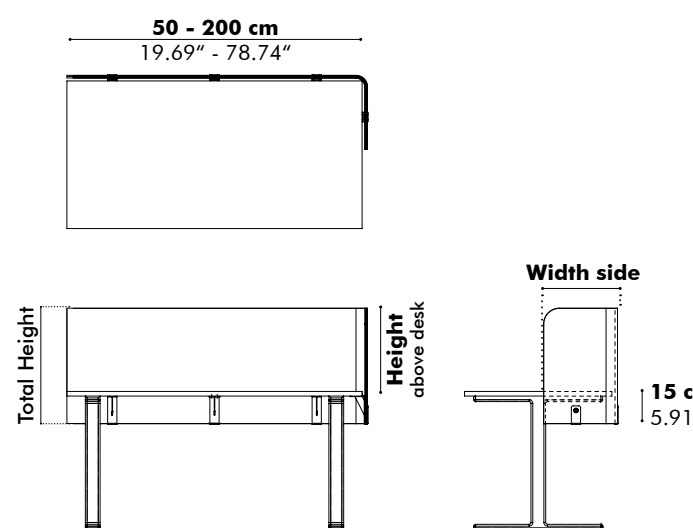

Total height (all models)

Height above desk

min:

52,5 cm / 20.67"

= (Total Height) - 15 cm / 5.91" - (Worktop Thickness)

max:

62,5 cm / 24.61"

= (Total Height) - 15 cm / 5.91" - (Worktop Thickness)

Width side (all models)

Height above desk

min:

22 cm / 8.66"

max:

47 cm / 18.50"

Finishes

3 layers of felt: 2 layers of BuzziFelt* with furniture felt core |
Fix in black (RAL 9005) or white (RAL 9010)
Round corners or wedge

Mounting

Comes with fixes than can be mounted with 3 screws underneath the worktop surface.

Desk mounted

BuzziTripl Wrap Desk Fix

Side: 1 fix(es) for the side

Front: 2 fix(es)/BuzziTripl Wrap Desk for width: 50-120 cm | 19.69"-47.24"

3 fix(es)/BuzziTripl Wrap Desk for width: 121-200 cm | 47.64" - 78.74"

Acoustics

Acoustic Principles

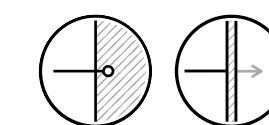

Absorption Attenuation

Acoustic Performance

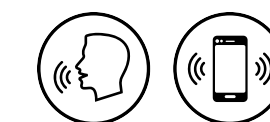

Mid Tones High Tones

How to order

Model

Total height

Width side(s)

Length front

BuzziFelt* color

Round corners or wedge

Color of fixes

*Not available in Ecobrown 58



BuzziTwist

— by Sas Adriaenssens

Sound-absorbing curved screen in sliced BuzziFelt

The BuzziTwist is an eye-catching free-standing room divider. It's a contemporary take on flexible room partitioning. The BuzziTwist is made from sliced BuzziFelt and has outstanding sound-absorbing properties.

Dimensions

Height

120 cm 47.24"

150 cm 59.06"

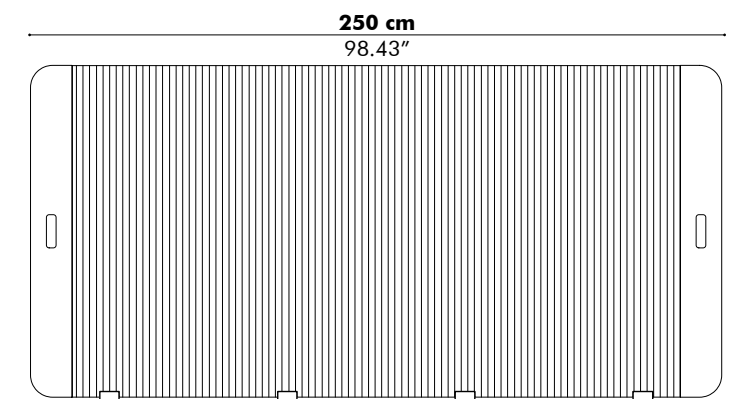

Finishes

2 layers of Sliced BuzziFelt with Felt core
Handles in felt & 4 feet in wood

Options

Different color front/back

Acoustics

Acoustic Principles

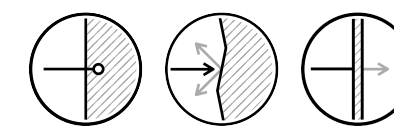

Absorption Diffusion Attenuation

Acoustic Performance



Low Tones Mid Tones High Tones

How to order

Size
Sliced BuzziFelt color combination
Options

BuzziWings

— by BuzziSpace Studio and designer duo COUVREUR.DEVOS

Suspended sound-absorbing dividing screen in BuzziFelt

These inventive BuzziFelt ceiling wings are designed to partition a large space acoustically and optically. BuzziWings not only ensure optimum sound quality, you also get a subtly lit room thanks to the integrated, indirect light source. The BuzziWings are attached to the ceiling at a 90° angle; perfect to shape the light and sound to your taste. Available in different BuzziFelt colors.



Aetna project - Wellworking
Photography: Leon Hargreaves

Dimensions

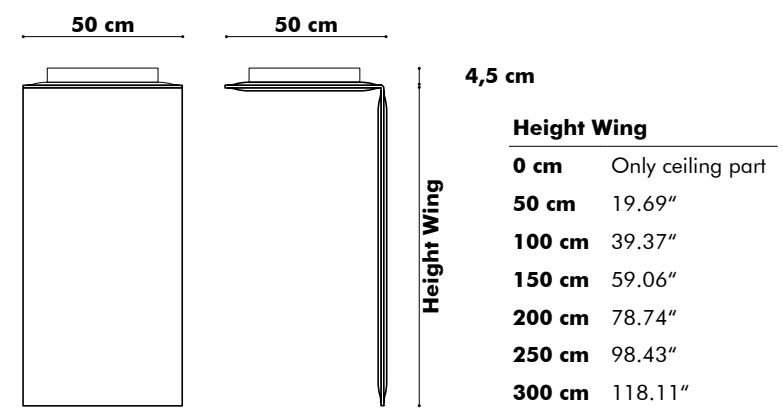

Finishes

Cover in BuzziFelt
Extra layer in fabric collections CAT A, B, C, D, E, F possible (check our application overview p. 330)

Mounting

Ceiling mounted
If installing on suspended ceiling, verify load capacity prior to installation



Aetna project - Wellworking
Photography: Leon Hargreaves

Options

Bicolor
Light (LED)

Acoustics

Acoustic Principles

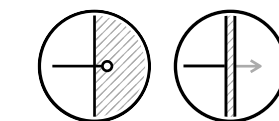

Absorption Attenuation

Acoustic Performance

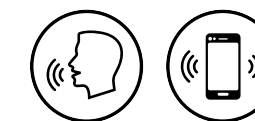

Mid Tones High Tones

How to order

Height Wing
Fabric (CAT > collection > color)
Options



Aetna project - Wellworking
Photography: Leon Hargreaves

BuzziWrap Desk

— by BuzziSpace Studio

Acoustic panel for any desk

BuzziWrap Desk is a shield for noise and visual distractions. As it wraps around your desk, it converts a plain worktop into a cocoon while hiding the typical cable clutter on the backside of your table. It's easy to install, and thanks to its various sizes and fix positions, it can be attached to almost any existing desk. In combination with the colorful palette of BuzziFelt, it will brighten up your day in silence.



Dimensions

BuzziWrap Desk Full

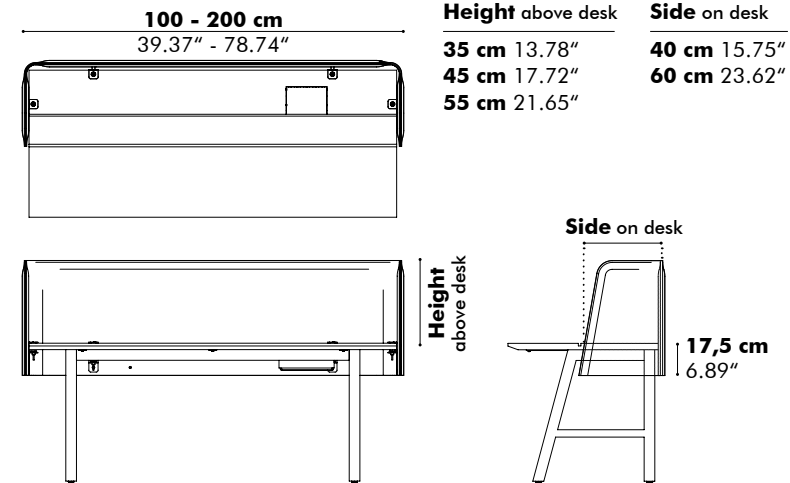

BuzziWrap Desk Left

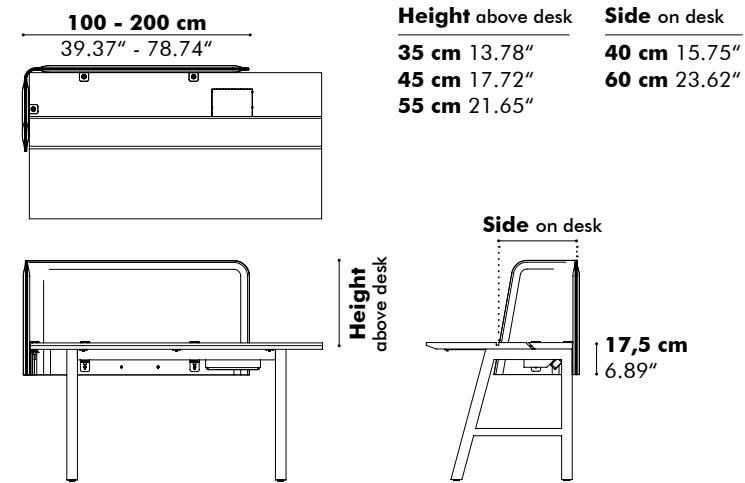

BuzziWrap Desk Right

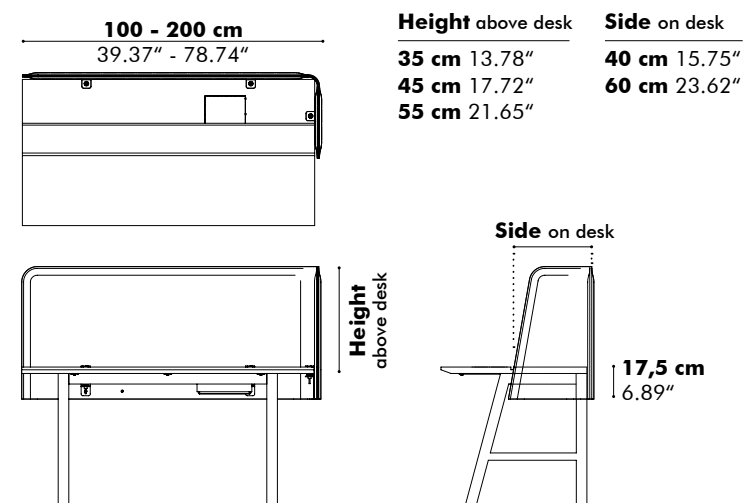

Finishes

Cover in BuzziFelt

Mounting

Desk mounted
 Fix - L - worktop thickness 12 mm - 0.47" > 27 mm - 1.06"
 Fix - L Plus - worktop thickness 18 mm - 0.71" > 43 mm - 1.69"
 Fix - XL - worktop thickness 28 mm - 1.10" > 57 mm - 2.24"
 Fix - XXL - worktop thickness 72 mm - 2.83" > 98 mm - 3.86"
 Fixes in black (RAL 9005), white (RAL 9010) or alu color (RAL 9006)

Options

Bicolor

Acoustics

Acoustic Principles

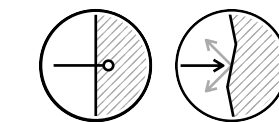

Absorption Diffusion

Acoustic Performance

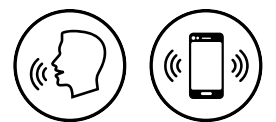

Mid Tones High Tones

How to order

Model
 Height above desk
 Side on desk
 Length front
 BuzziFelt color
 Size fix front
 Size fix side
 Color of fixes
 Options



BuzziWrap FrontDesk

— by BuzziSpace Studio

A shield for uninterrupted focus

Focus areas are not limited to privacy booths and soundproof rooms. They come in many shapes and sizes. BuzziWrap FrontDesk is proof of that. With its large front, it converts a regular desk into a more private workstation, shielding out noise and distractions, to allow for uninterrupted focus, while concealing the cable cord clutter, which typically hangs off the rear of a desk. Easily attach it to almost any desk and choose among all the vibrant BuzziFelt colors to brighten up your workspace.



Dimensions

BuzziWrap FrontDesk Full

100 - 160 cm 39.37" - 62.99"	Height above desk	Side on desk
	35 cm 13.78"	40 cm 15.75"
	45 cm 17.72"	60 cm 23.62"
	55 cm 21.65"	

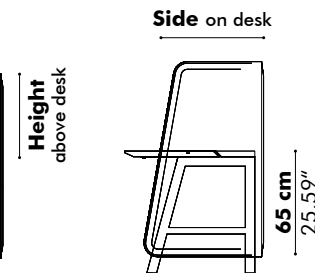
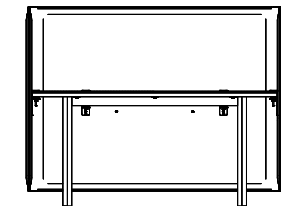
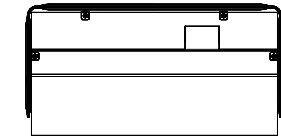

BuzziWrap FrontDesk Left

100 - 200 cm 39.37" - 78.74"	Height above desk	Side on desk
	35 cm 13.78"	40 cm 15.75"
	45 cm 17.72"	60 cm 23.62"
	55 cm 21.65"	

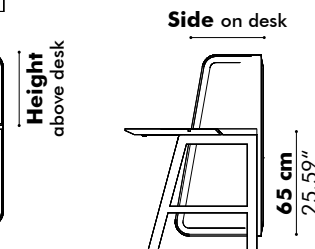
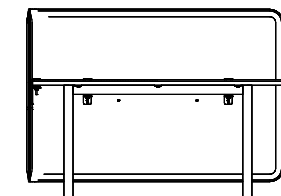
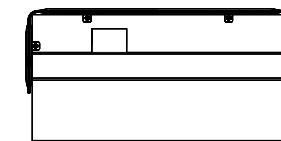

BuzziWrap FrontDesk Right

100 - 200 cm 39.37" - 78.74"	Height above desk	Side on desk
	35 cm 13.78"	40 cm 15.75"
	45 cm 17.72"	60 cm 23.62"
	55 cm 21.65"	

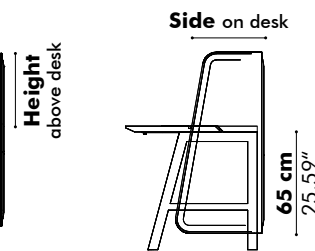
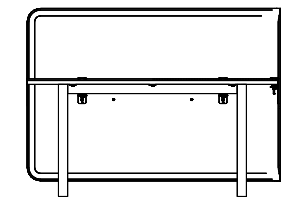
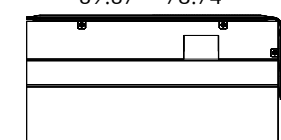

Finishes

Cover in BuzziFelt

Mounting

Desk mounted

- Fix - L - worktop thickness 12 mm - 0.47" > 27 mm - 1.06"
 - Fix - L Plus - worktop thickness 18 mm - 0.71" > 43 mm - 1.69"
 - Fix - XL - worktop thickness 28 mm - 1.10" > 57 mm - 2.24"
 - Fix - XXL - worktop thickness 72 mm - 2.83" > 98 mm - 3.86"
- Fixes in black (RAL 9005), white (RAL 9010) or alu color (RAL 9006)

Options

Bicolor

Acoustics

Acoustic Principles

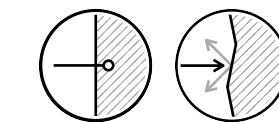

Absorption Diffusion

Acoustic Performance

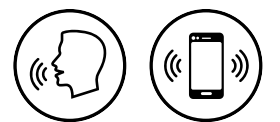

Mid Tones High Tones

How to order

- Model
- Height above desk
- Side on desk
- Length front
- BuzziFelt color
- Size fix front
- Size fix side
- Color of fixes
- Options

BuzziZepp

— by Alain Gilles

A suspended, linear acoustic panel

BuzziZepp is an impressive, sound-absorbing panel offering acoustic treatment to a space. The suspended design was conceived by designer Alain Gilles as an “imaginary island” to visually delineate and bring a sense of tranquility to large open spaces. With its striking linear design, BuzziZepp hovers from above to define zones without obstruction, establishing a more intimate, quiet and purposeful sense of space—no vertical partitions or walls needed! The slim framework is made of upholstered acoustic panels, engineered to absorb sound and reduce echo.



Models

S

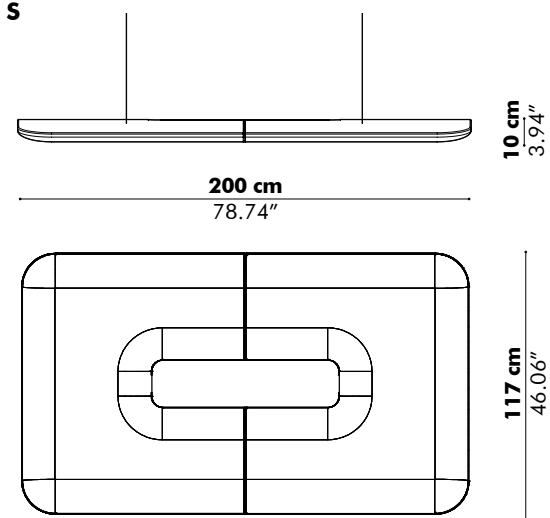

M

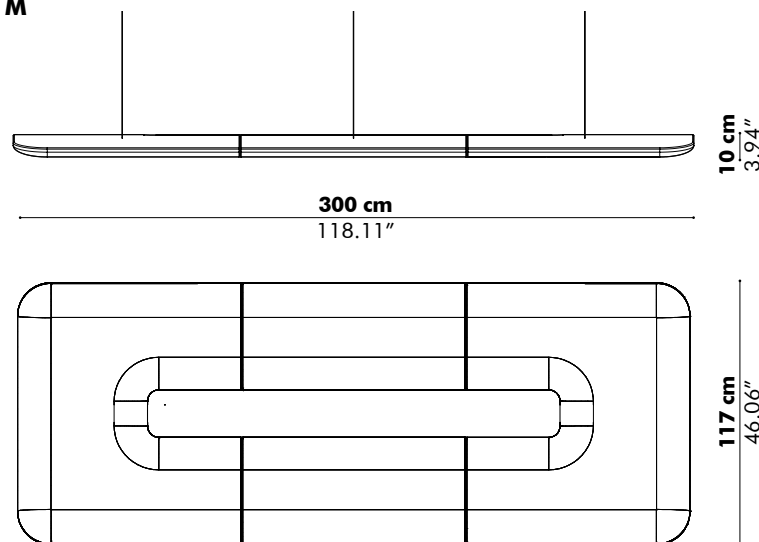

Finishes

Upholstery in fabric collections CAT A, B, C, D, E, F (check our application overview p. 330)

Mounting

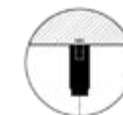

Ceiling Suspended
Fixing System Screw with 6 or 8 cables of 2 m - 78.74" or 5 m - 196.85" (black or alu)



The acoustic panel can be mounted straight or slanted, with a maximum angle of 20° to create a more secluded setting.

Acoustics

Acoustic Principles

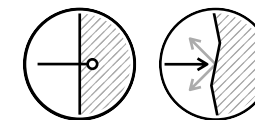

Absorption Diffusion

Acoustic Performance



Low Tones Mid Tones High Tones

How to order

Size
Fabric (CAT > collection > color)
Mounting option

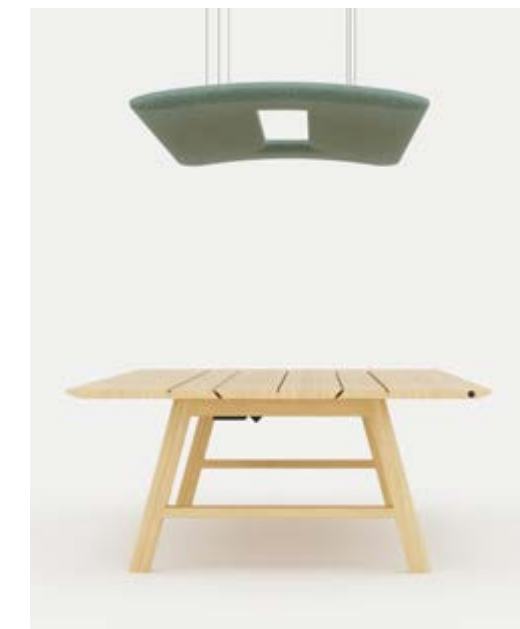

ACOUSTIC
FURNITURE



BuzziBalance — 162

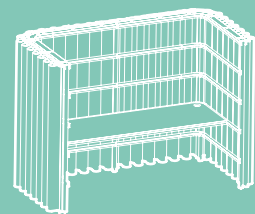

BuzziBracks — 167

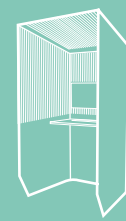

BuzziBooth — 173



BuzziCube Flat — 176

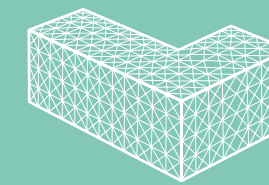

BuzziCube 3D — 178

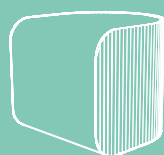

BuzziDee — 180

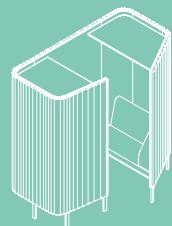

BuzziHive — 185



BuzziHood — 187



BuzziHub — 189



BuzziHug — 190



BuzziMe — 193

ACOUSTIC FURNITURE



BuzziNest — 197



BuzziPouf — 205

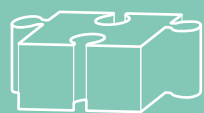

BuzziPuzzle — 207

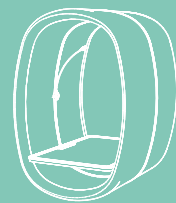

BuzziRing — 208



BuzziSpark — 210



BuzziSpot — 217

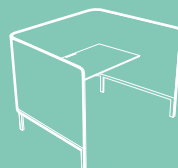

BuzziTemp — 219

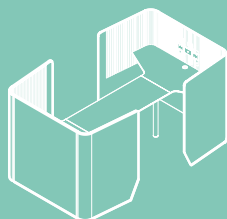

BuzziVille — 220

BuzziBalance

— by 13&9 Design

Move your body, move your mind

BuzziBalance creates a non-traditional environment that brings people together, provoking joy and conversation. The BuzziBalance family offers both a seating and standing element.

While standing, BuzziBalance Board becomes a muscle activator. As one balances on the wooden-carved rocking board for a few moments, the mind and body are awakened. While sitting on the BuzziBalance, a rocking pouf in small and large version, the benefits of purposeful stretching are brought into the workplace. The upholstered seat also offers added acoustical benefits.

The perfect solution for creative hubs in the workplace, hospitality or residential homes. BuzziBalance offers the best of both worlds. Stretch your legs for a quick phone call or gather and rock away during a creative session.





Models

Balance

Small

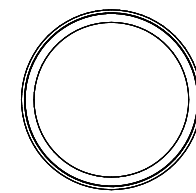

Ø 56 cm
22.05"

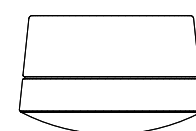

38 cm
14.96"

Large

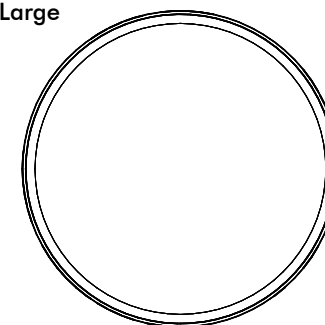

Ø 98 cm
38.58"

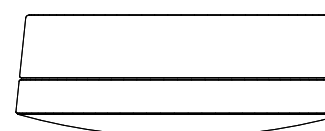

Small High

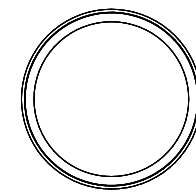

Ø 56 cm
22.05"

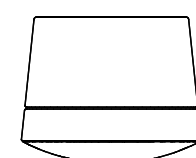

46.5 cm
18.30"

Balance Board

Small

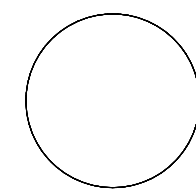

Ø 55 cm
21.65"



7 cm
2.76"

Large

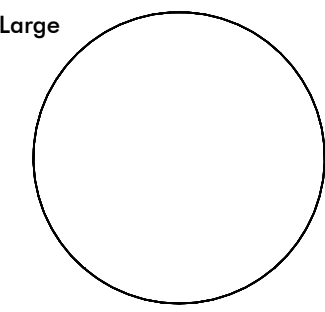

Ø 97 cm
38.19"



Finishes

Bottom in solid wood ash natural (varnish)
Upholstery in fabric collections CAT A, B, C, D, E, F
(check our application overview p. 330)

Acoustics

Acoustic Principles

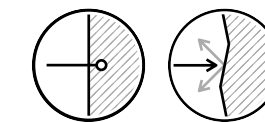

Absorption Diffusion

Acoustic Performance



Low Tones Mid Tones High Tones

How to order

Model
Size
Fabric (CAT > collection > color)



BuzziBracks

— by Alain Gilles

A room within a room

BuzziBracks found its way to the drawing board to answer the need for flexible, new ways of working. In open spaces, this modular unit system can be combined in numerous ways to create different areas—to work, focus, relax or meet. The curtains, available in a wide color palette, act as a visual as well as an acoustic shield from the surroundings, separating one zone from the other. Combine transparent with non-transparent curtains and open or close them as needed for privacy. Be your own architect and continuously create and recreate microenvironments within open workspaces.

Sizes

Medium

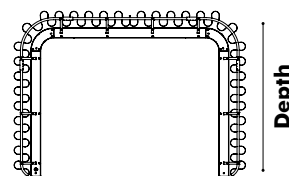
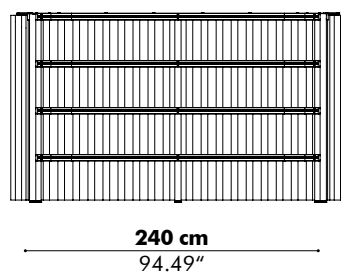
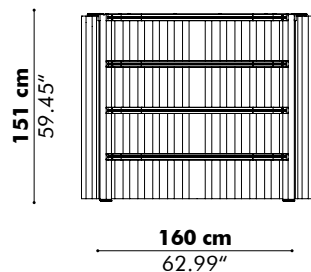

Depth	
120 cm	47.24"
150 cm*	59.06"

*Not possible with width 160 cm | 62.99" inch

Dimensions excl. rails & curtains

High

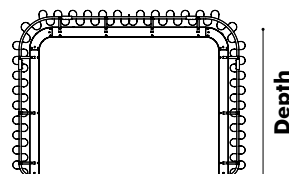
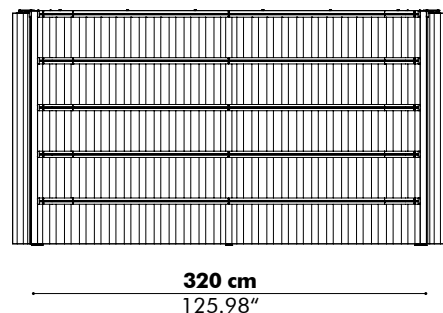
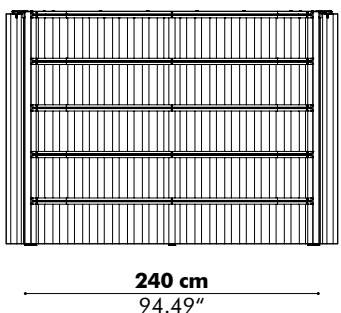
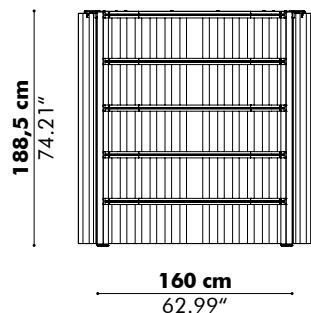

Depth	
120 cm	47.24"
150 cm*	59.06"

*Not possible with width 160 cm | 62.99" inch

Dimensions excl. rails & curtains

Extra High

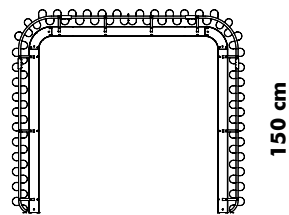
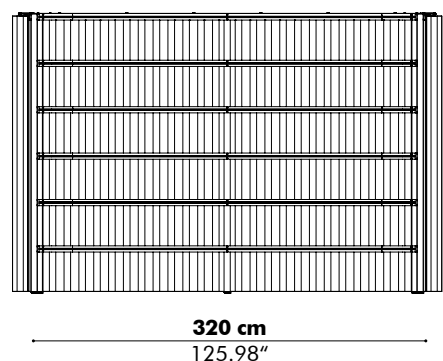
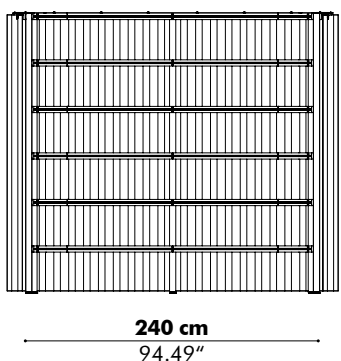
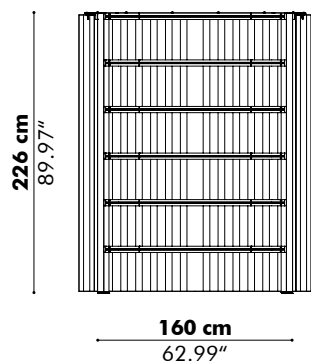

Dimensions excl. rails & curtains

Curtains

2 pcs symmetrical

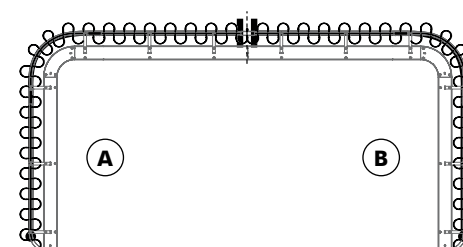

2 pcs asymmetrical

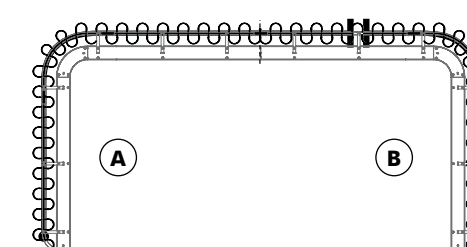

(A) + (B)

Curtains A and B can be chosen in a different curtain collection and color.

Worktops

Worktop Full

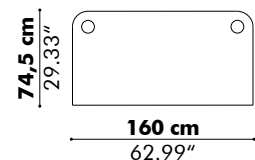
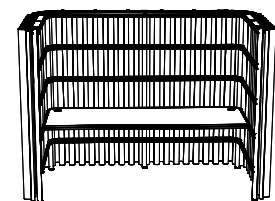

Worktop A

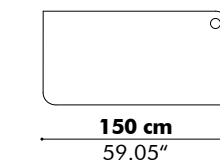
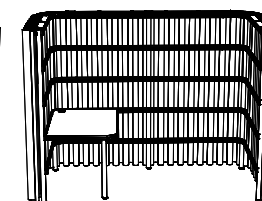
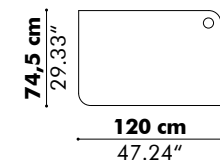
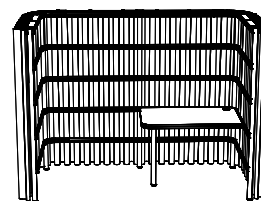

Worktop B

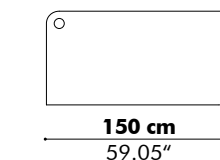
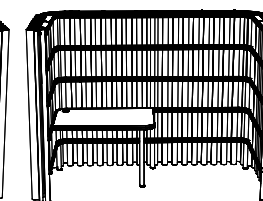
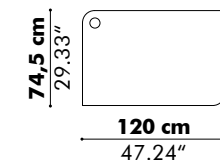
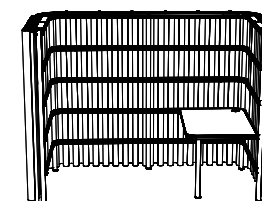

Cable entries | cutouts for electrification are optional

Meeting Tables

Meeting table Medium

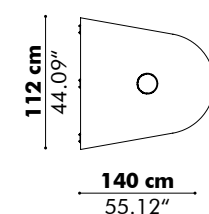
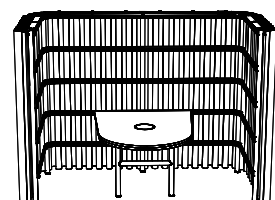

Meeting table Large

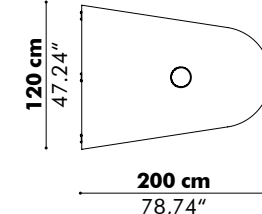
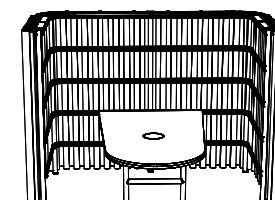

Can be used for standing or seating
Cutouts for electrification optional

Cover

Metal finish to cover rails in same color as frame.

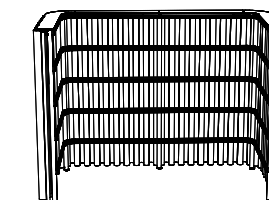

Shelves

Shelf Full

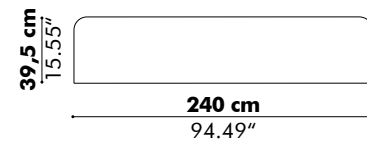
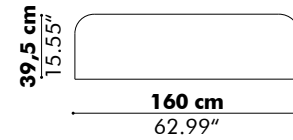
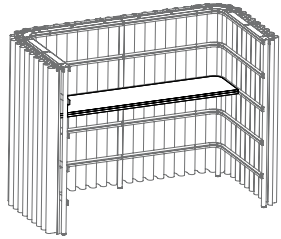

Shelf A

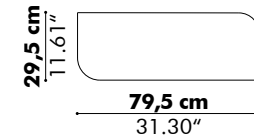
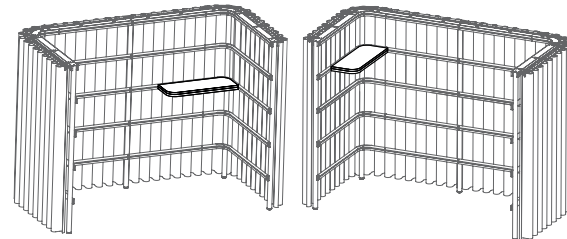

Shelf B

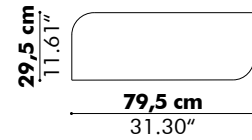
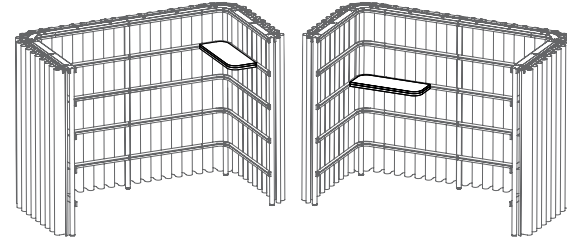

Accessories

Pinboard BuzziFelt

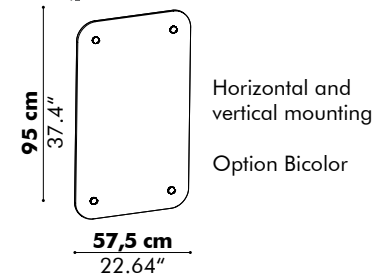
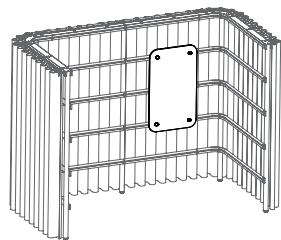

Hooks

Finish: Antwerp oak

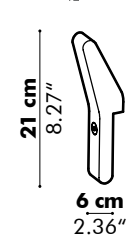
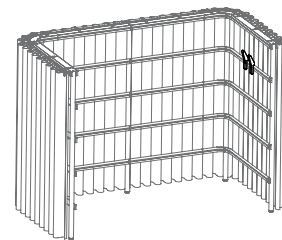

Universal Mount

For display or whiteboard

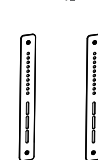
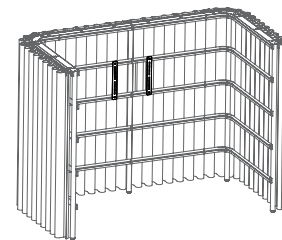

Flag

Finish: Antwerp oak

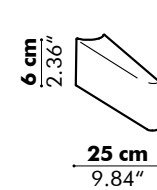
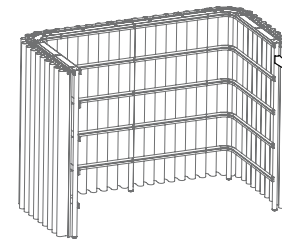

Options

Netbox point for worktops

Set comes with 3 Communication modules (1 x HDMI, 1 x DATA, 1 x USB)
Select 2 to connect to the netbox point

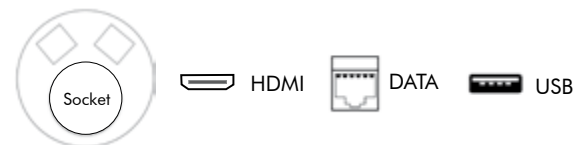

Cable box for meeting tables

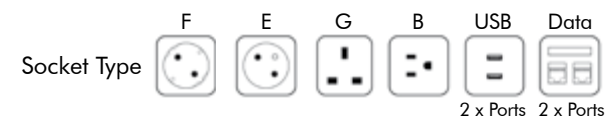
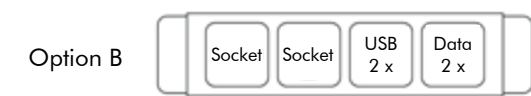
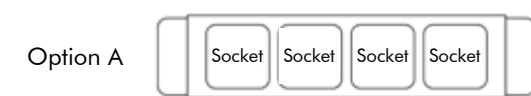

Finishes

Frame

Powder coated metal in Beige Red (RAL 3012), Black Green (RAL 6012), Pastel Blue (RAL 5024), Pastel Green (RAL 6019), Light Green (RAL 6027), Signal Grey (RAL 7004), Black (RAL 9005)

Curtains

CUR A, B, C, D or F (check our application overview p. 330)

Worktop & Shelves



Antwerp Oak White Laminate

Supportive frames for worktop and shelves in same metal color as frame

Acoustics

Acoustic Principles

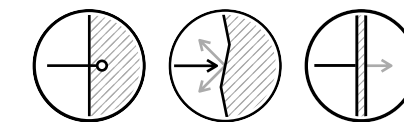

Absorption Diffusion Attenuation

Acoustic Performance

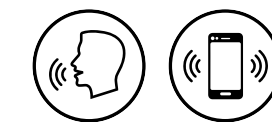

Mid Tones High Tones

How to order

Size frame (height, depth, width)
Finish frame
Curtains (CUR > collection > color)
Worktop (model, size, finish)
Shelf (model, size, finish)
Accessories (size, finish)

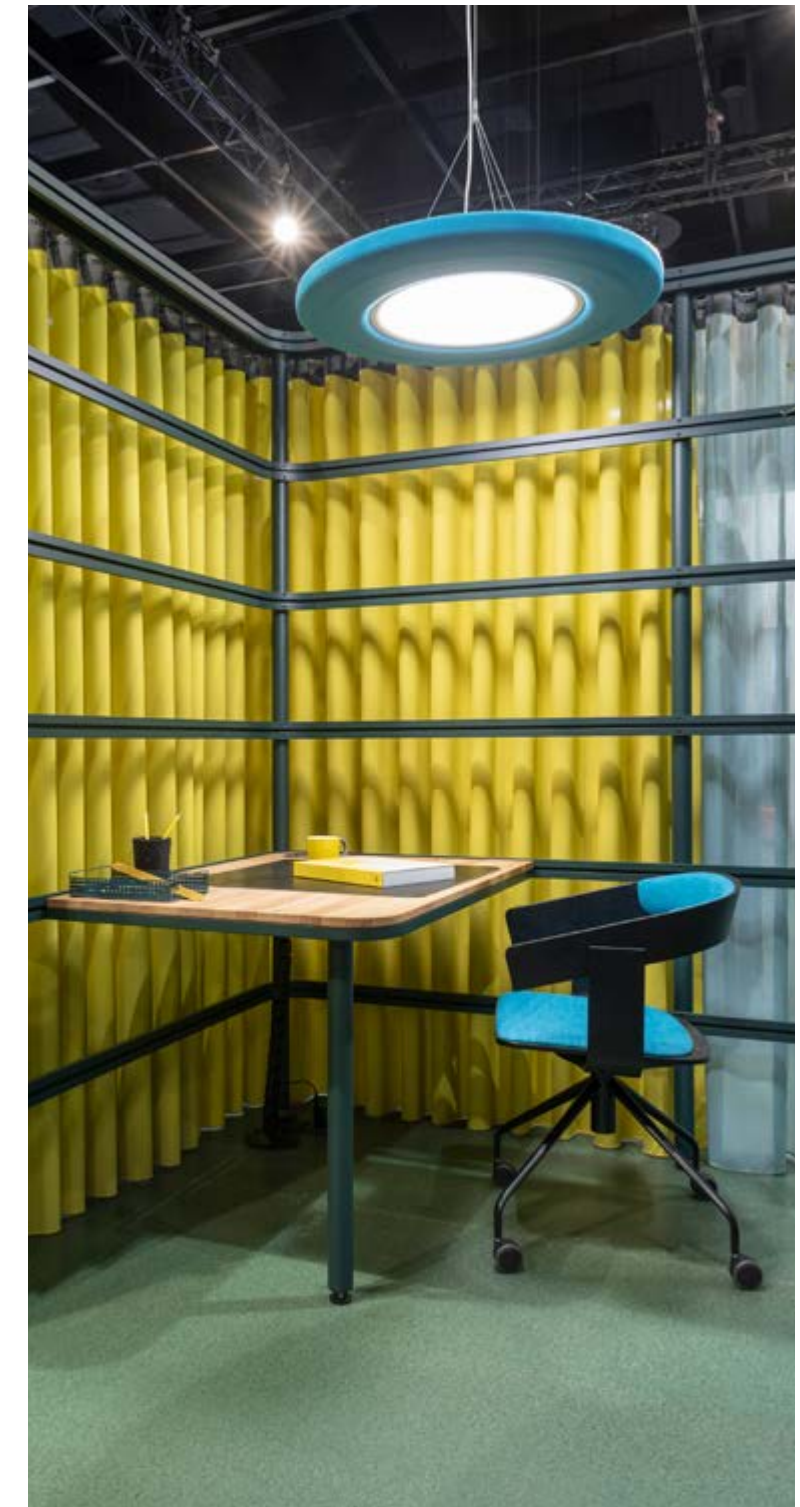

Bern University, CH
Photographer: Christine Strub



Mediateka - Sopot by Sikora Interiors
Photography: Tom Kurek

BuzziBooth

— by Alain Gilles

Upholstered temporary workstation

There has been a big shift toward working in open-plan offices that have a loft-like feeling of home. While there are many benefits, the challenge is maintaining space to make a phone call or work quietly and independently. Designer Alain Gilles' solution is the BuzziBooth: a phonebooth that dampens outside sounds. Now you can have a moment alone even in the noisiest of surroundings. Micro-architecture for maxi spaces!

Models

Single

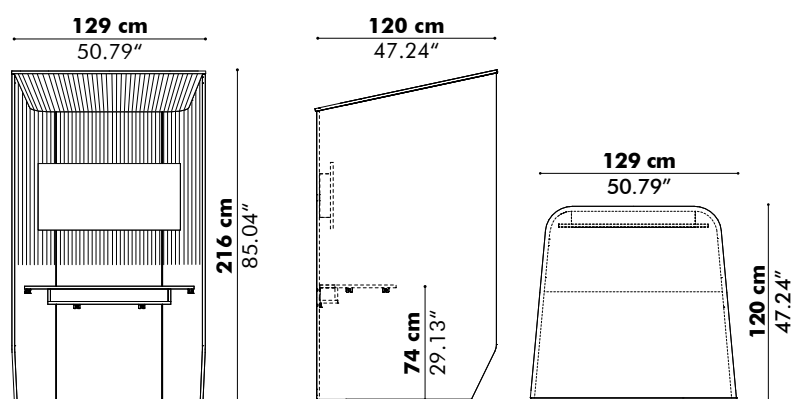

Standing

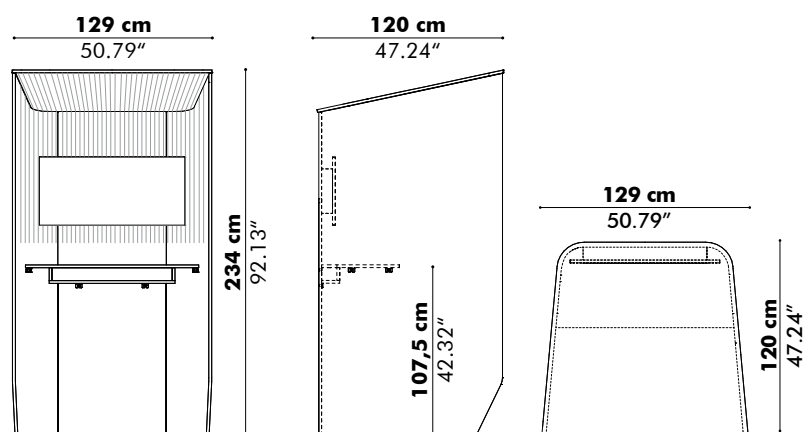

Patterns

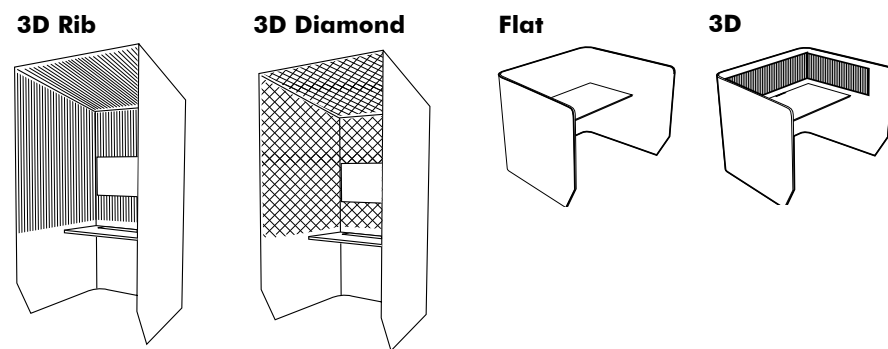

Finishes

Upholstery Hub Single & Standing
 in fabric collections CAT A, E
 (check our application overview p. 330)
 Worktop upholstered

Options

Bicolor
 Light (LED) + panel

Standing:

- Worktop in white laminate (without cable tray) or in Antwerp Oak (with or without cable tray)

Acoustics

Acoustic Principles

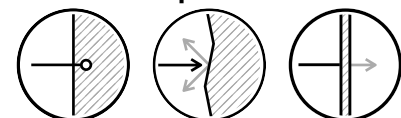

Absorption Diffusion Attenuation

Acoustic Performance



Mid Tones High Tones

How to order

Model
 3D Rib or Diamond for Single, Standing,
 Flat or 3D for Targa
 Fabric (CAT > collection > color)
 Options

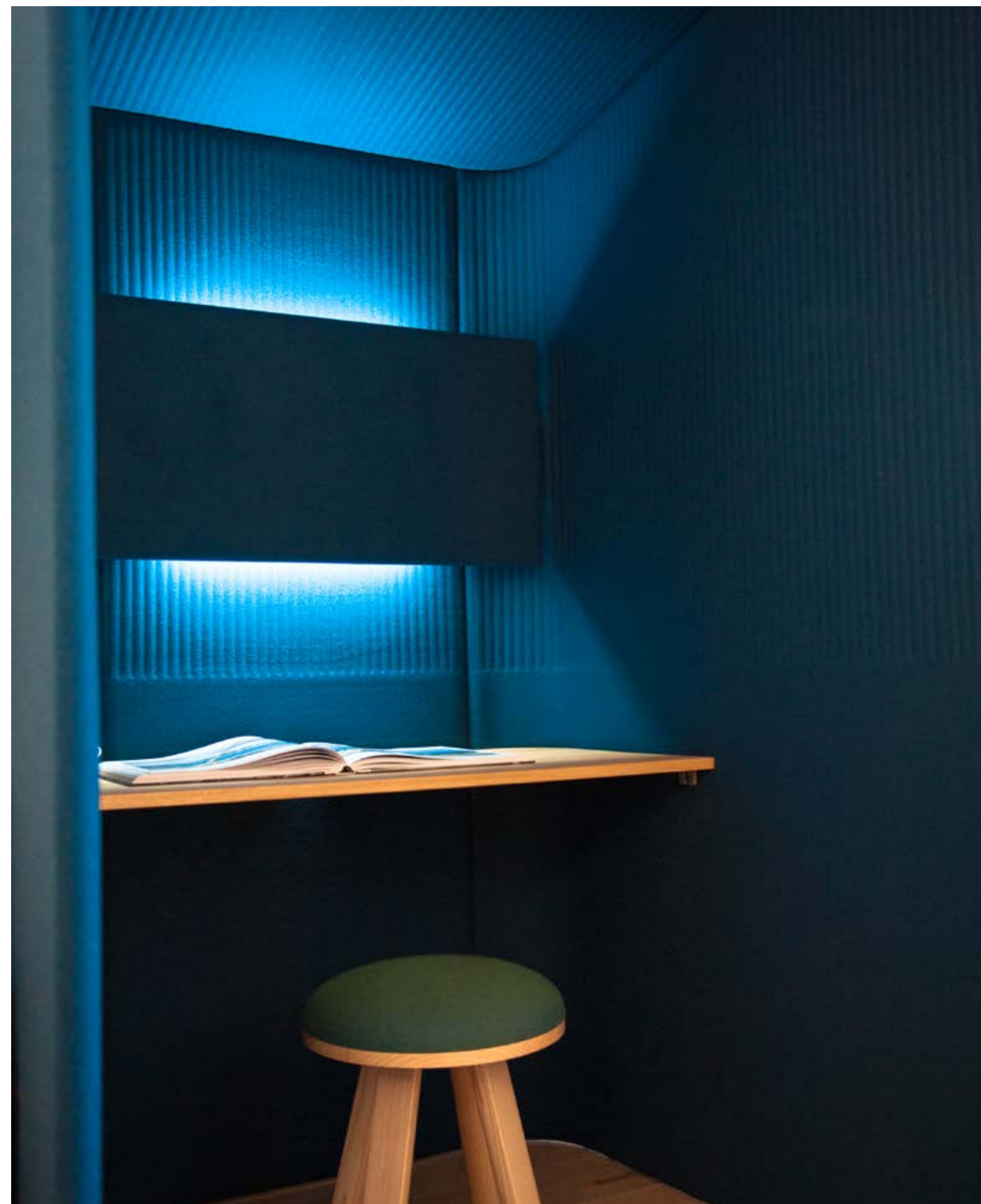

BuzziCube Flat

— by BuzziSpace Studio

Sound-absorbing pouf

The BuzziCube Flat makes sitting a pleasure for your eyes and your bottom. Upholstered with soft foam and covered by a variety of BuzziSpace fabrics, it is bound to steal the show in any interior!

Models

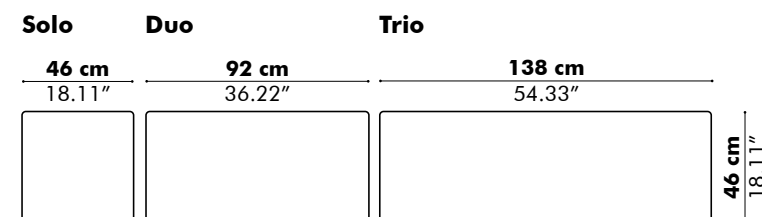

Quatro

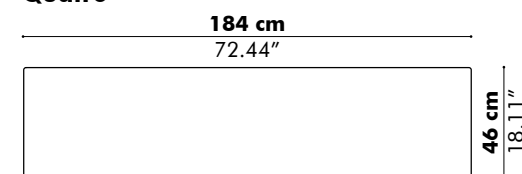

Bottom

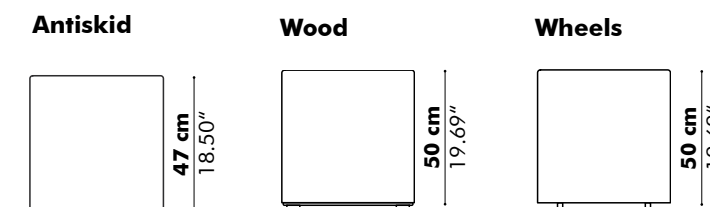

Finishes

Upholstery in fabric collections CAT A, B, C, D, E, F (check our application overview p. 330)

Acoustics

Acoustic Principles

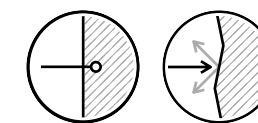

Absorption Diffusion

Acoustic Performance



Low Tones Mid Tones High Tones

How to order

Model

Bottom

Fabric (CAT > collection > color)



BuzziCube 3D

— by BuzziSpace Studio

A sound-absorbing 3D pouf

BuzziCube makes sitting a pleasure. A high-design pouf that is unique in its class thanks to its revolutionary form and high-tech production process. The 3D foam covered with a variety of BuzziSpace fabrics gives it a unique touch.



Volkswagen Financial IT offices - Berlin
Photography: Andrea Janssen

Models

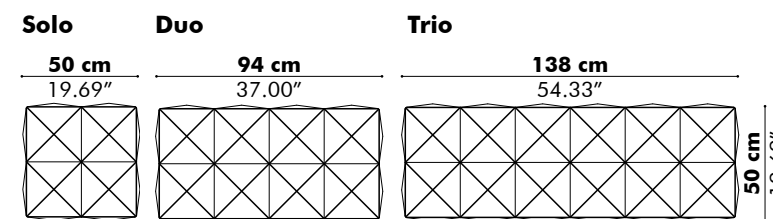

Quatro

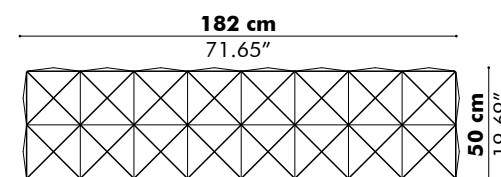

Bottom

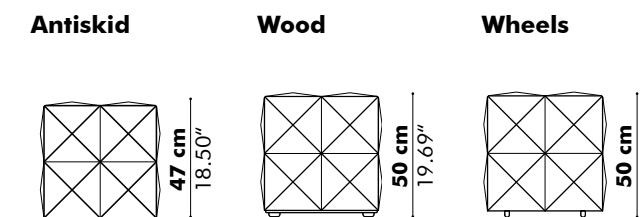

Patterns

1 SQ

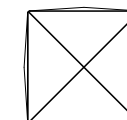

4 SQ

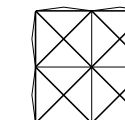

16 SQ

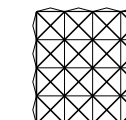

Finishes

Upholstery in fabric collections CAT A, E
(check our application overview p. 330)

Acoustics

Acoustic Principles

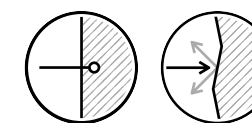

Absorption Diffusion

Acoustic Performance



Low Tones Mid Tones High Tones

How to order

Model
Bottom
Pattern
Fabric (CAT > collection > color)

BuzziDee

— BuzziSpace Studio

Versatile pouf with exceptional acoustic capabilities

A, B, C, BuzziDee. With this originally-shaped acoustic pouf in the room, you can speak out without worrying about disturbing coworkers thanks to the sound-absorbing capabilities. Featuring rounded corners on top and below, BuzziDee's eye-catching curvature adds structural integrity for maximum comfort; meanwhile, its firm yet lightweight body makes it easy for users to rearrange or store away BuzziDee as needed, or pull up as extra seating in a meeting room or communal space.



Models

Solo

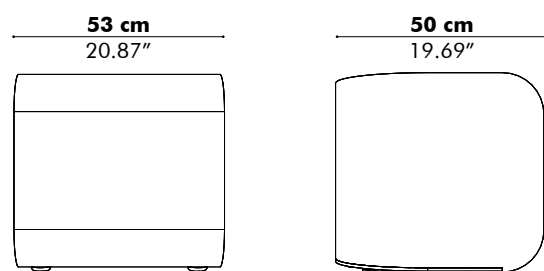

Solo Large

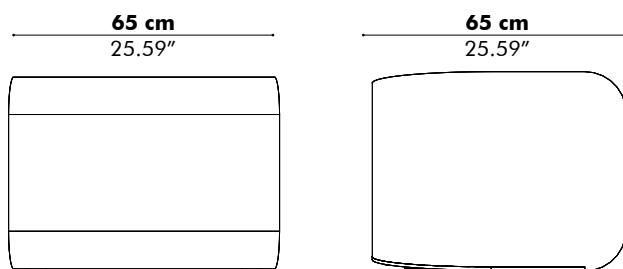

Trio

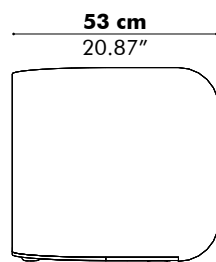
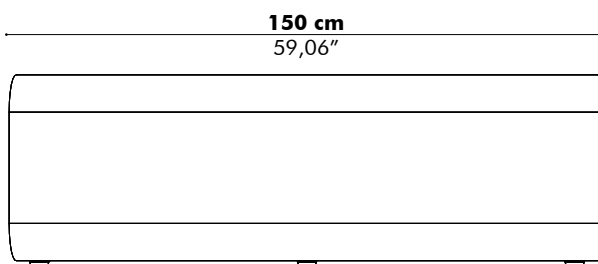

Plus

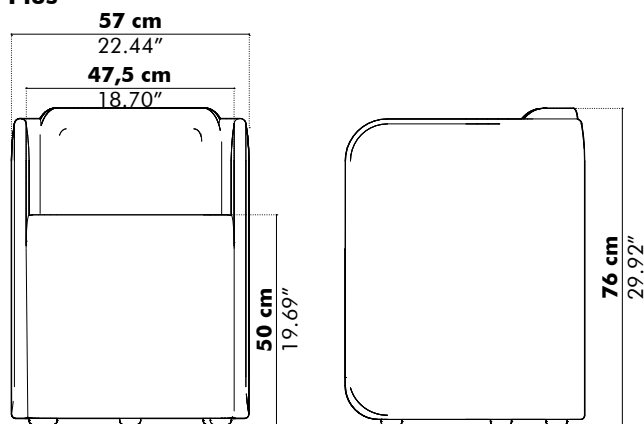

Bottom

Antiskid

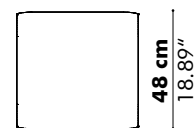

Wood



Wheels

(only for BuzziDee Plus)

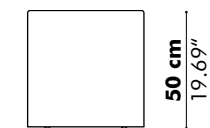

Patterns

Flat

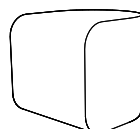

3D Rib Top & Front

(not available for BuzziDee Plus)

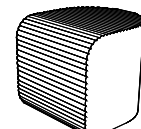

3D Rib Side

(not available for BuzziDee Plus)

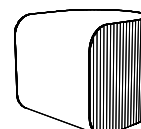

Finishes

Upholstery in fabric collections CAT A, B, C, D, E, F (only for Dee flat) (check our application overview p. 330)

Options

Bicolor (in same fabric collection)

Tablet in Ash black stained with black metal support (only for Dee Plus)

Acoustics

Acoustic Principles

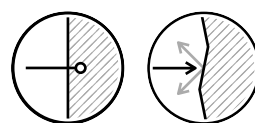

Absorption Diffusion

Acoustic Performance



Low Tones Mid Tones High Tones

How to order

Model

Bottom

Pattern

Fabric (CAT > collection > color)

Option

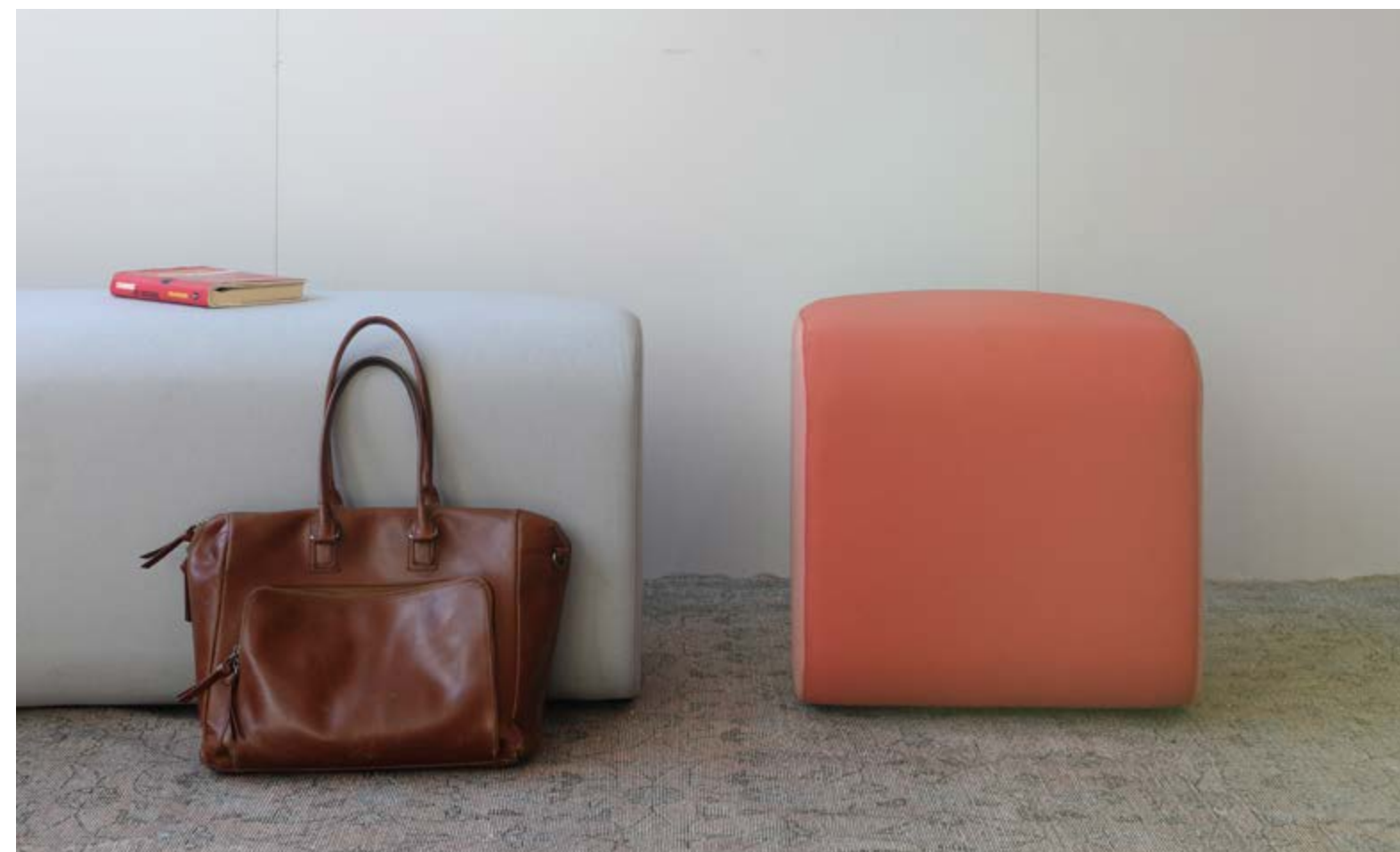

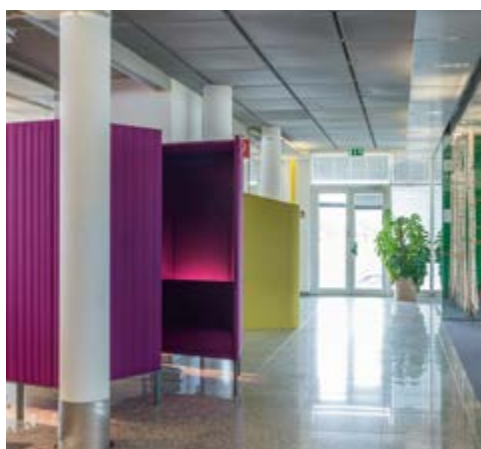

Russmedia – Graz
Photography: Jens Ellensohn

BuzziHive

— by Alain Gilles

Temporary work and meeting space

An acoustic cocoon (inspired by train compartments) that ensures a private, three-person meeting room without losing contact with the surroundings. BuzziHive can be used as a stand-alone element in any space. It can also be combined with other BuzziHives, creating a beehive effect.

Dimensions

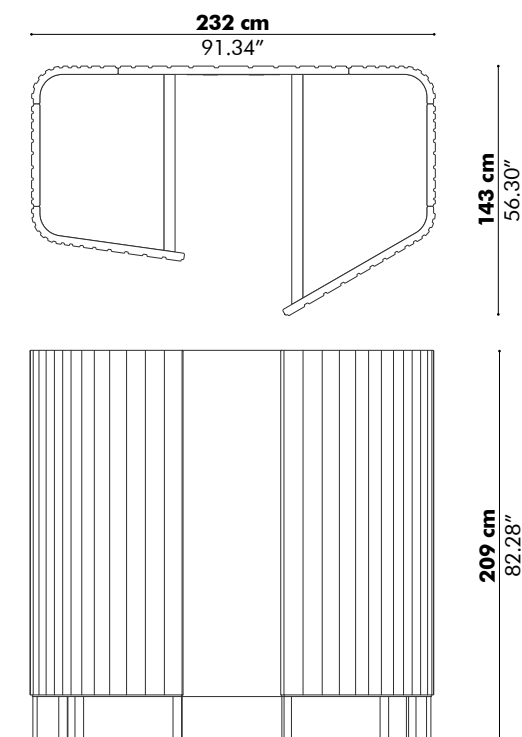

Finishes

Upholstery in fabric collections CAT A, B, C, D, E, F (check our application overview p. 330)
Base powder coated metal in Umbra Grey (RAL 7022)
3D rib outside

Options

Bicolor
LED
Cushion

Acoustics

Acoustic Principles

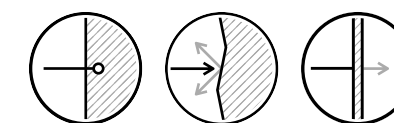

Absorption Diffusion Attenuation

Acoustic Performance

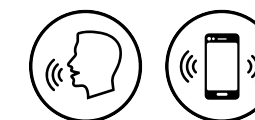

Mid Tones High Tones

How to order

Fabric (CAT > collection > color)
Options



BuzziHood

— by Alain Gilles

Wall-mounted acoustic telephone booth

BuzziHood is an acoustic cocoon you can hang on the wall. When you're 'in the Hood' you can answer the phone in noisy surroundings without having to ask the caller to repeat himself. It can be installed anywhere and will cheer up any space!

Dimensions

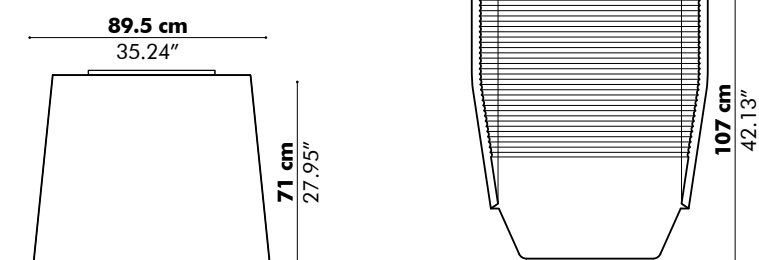

Patterns

Flat

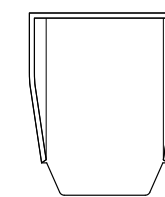

3D

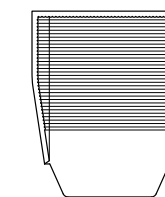

Finishes

Upholstery in fabric collections CAT A, B, C, D, E, F (check our application overview p. 330)

Options

Bicolor

Tablet

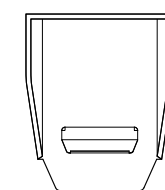

Inclined in powder coated metal black (RAL 9005) or white (RAL 9010)

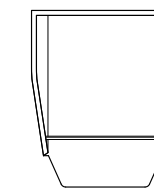

Horizontal in wood 18 mm - 0.71" oak

Acoustics

Acoustic Principles

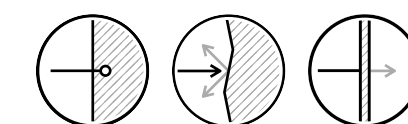

Absorption Diffusion Attenuation

Acoustic Performance

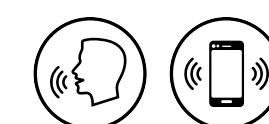

Mid Tones High Tones

How to order

Pattern
Fabric (CAT > collection > color)
Options



360i - London
Photography: Grey Limited



Mediateka - Sopot by Sikora Interiors
Photography: Tom Kurek

BuzziHub

— by Alain Gilles

Temporary work or meeting space

BuzziHub is a space where people can easily come together and share information. It has been designed to become a central point in the social life of an office. It can serve as an informal meeting room for temporary or full-time employees. BuzziHub has been designed in order to make you feel at home. It is a warm and comfortable environment made to facilitate communication and improve personal well-being.

Models

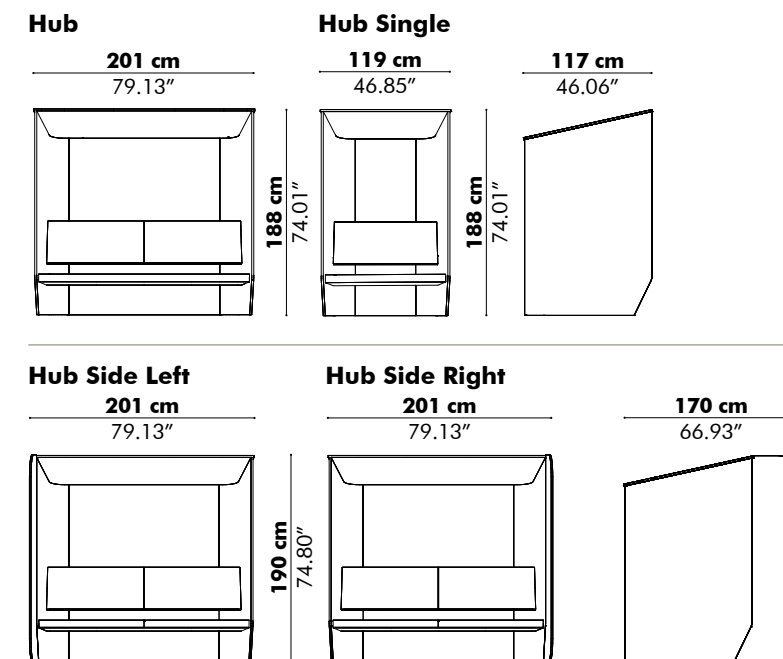

Patterns

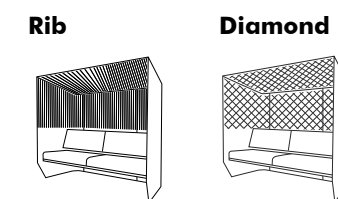

Finishes

Upholstery in fabric collections A, E
Upholstery Bench in collections A, B, C, D, E, F
(check our application overview p. 330)

Options

BuzziHub Cushion
BuzziHub Armrest
Bicolor
Light (LED)

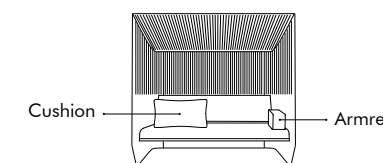

Acoustics

Acoustic Principles

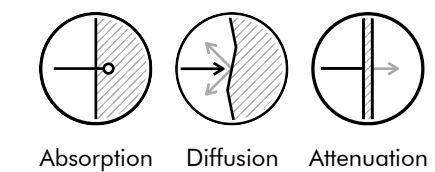

Absorption Diffusion Attenuation

Acoustic Performance

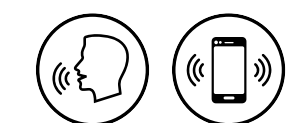

Mid Tones High Tones

How to order

Model
Pattern
Fabric (CAT > collection > color)
Options

BuzziHug

— by BuzziSpace Studio

A versatile privacy booth for the ever-changing workspace

BuzziHug perfectly balances between being a semi-enclosed privacy booth as well as an individual stand-up desk. Because of its voluminous upholstered body, BuzziHug effectively mitigates excessive noise while doubling as an unexpected design element within any workspace. With occupancy for one, the semi-enclosed acoustic solution instantly creates a cozy and safe working environment for employees to hold video calls or to get focused work done. Due to its lightweight and organic structure, combining more than one BuzziHug to divide open spaces and creating a visually stunning atmosphere while absorbing sound is simple. Additionally built with a sturdy core, BuzziHug can also be bolted to the ground to prevent it from falling over during earthquakes and seismic shocks.

Dimensions

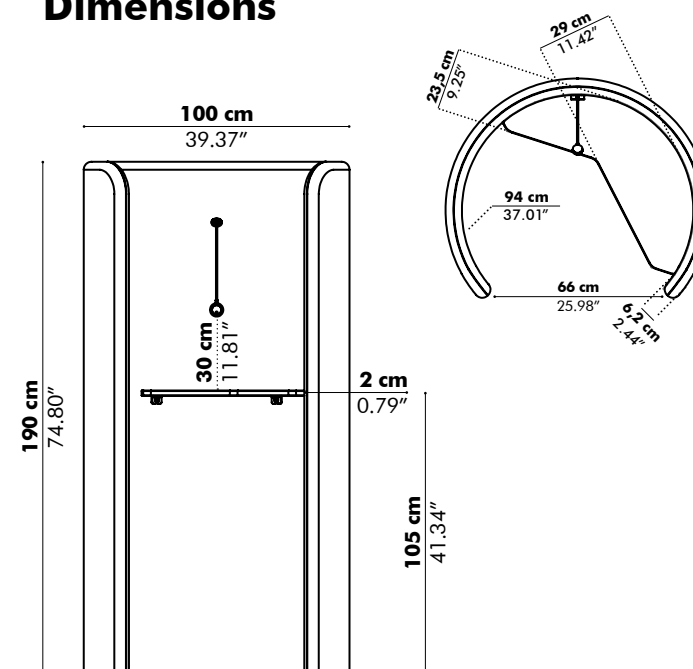

Finishes

Tablet: Antwerp Oak or White Laminate

4 adjustable feet are included

2 fixing plates are included

(powder coated metal in black RAL 9005)

Fabrics: Fabric, Trevira CS+ |CS, Revive 1, Remix 3, Clara 2, Hero, Tonus 4 or Memory 2

(check our application overview p. 330)

Tablet



Antwerp Oak



White Laminate

Fixing plates



Options

LED light in black aluminium with two USB chargers, power adapter (EU, UK or US)

How to order

Fabric (CAT > Collection > color), worktop material, option

Acoustics

Acoustic Principles

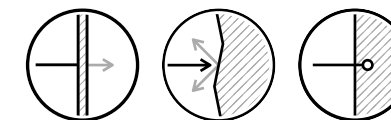

Attenuation Diffusion Absorption

Acoustic Performance



Low Tones Mid Tones High Tones





BuzziMe

— by Axel Enthoven

Lounge Chair

Me, myself and I: there are times when you want to spend some time on your own in peace and quiet. BuzziMe is the ideal space to get away from it all. Belgian designer Axel Enthoven was responsible for an ingenious look that harmoniously combines functionality and ergonomics. Put two BuzziMe lounge chairs together for a private meeting. The acoustic absorption of the lounge chair reduces any external noise and vice versa: the perfect chair for lobbies, airports and offices - or your very own 'quiet' cocoon at home.

Models

BuzziMe

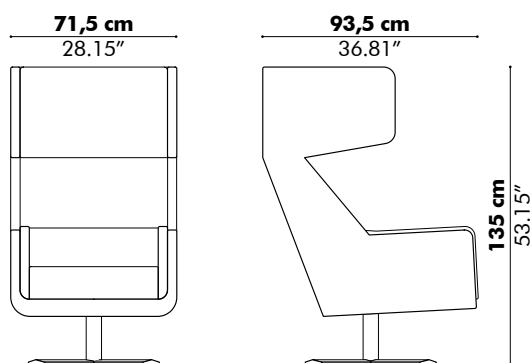

BuzziMe Low

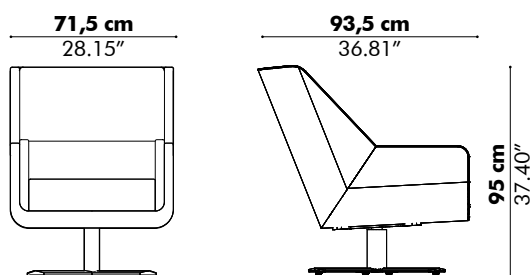

BuzziMe Ottoman

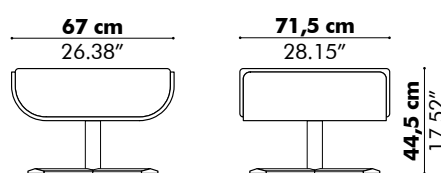

Finishes

Upholstery in fabric collections CAT A, B, C, D, E, F
(check our application overview p. 330)
Base powder coated metal in Umbra Grey (RAL 7022)

Options

Bicolor

Different color inside / outside

Tablet

Tablet 28 x 23 cm | 11.02" x 9.06"
RAL 7022 (umbra grey)

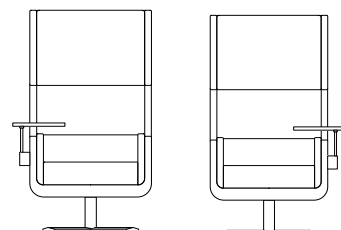

Tablet left

Tablet right

Acoustics

Acoustic Principles

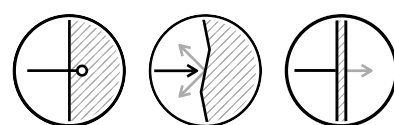

Absorption Diffusion Attenuation

Acoustic Performance



Mid Tones High Tones

How to order

Model

Fabric (CAT > collection > color)

Options





BuzziNest

— by BuzziSpace Studio

Silent workspaces anywhere

BuzziNest Booth and Pod are great alternatives to expensive infrastructure and all you need to erase distracting noise from any workplace. The compact and mobile acoustic privacy Booth for one offers a private space to work and take calls, while BuzziNest Pod allows up to four people to hold face-to-face meetings and collaborations in any open space without disturbing others, and most importantly, being disturbed. Because of its luxe upholstered exterior and fabric panels on the interior, BuzziNest effectively dampens sound from every direction to create maximum peace and quiet for everyone in the office, whether you are working inside BuzziNest or out. A range of customizations and furniture add-ons are also available for BuzziNest.



Dimensions

BuzziNest Booth

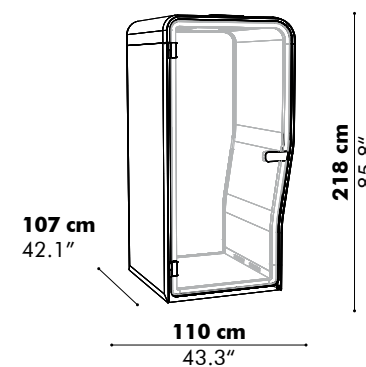

310 kg | 683 lbs
1.2 m² | 12 sqf

BuzziNest Pod

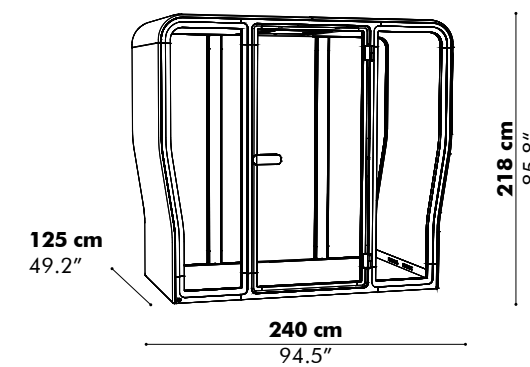

590 kg | 1300 lbs
3 m² | 32 sqf

Models

BuzziNest Booth

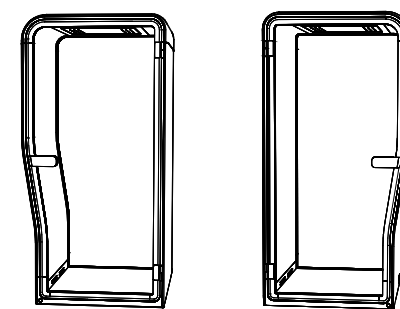

Right-handed

Left-handed

BuzziNest Pod

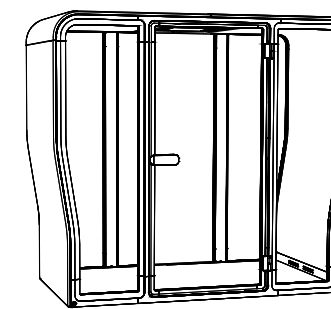

Finishes

Fabrics and Felts

Exterior: Fabric covered foam with Fabric or Trevira CS+
Interior: Felt, Felt Printed or 3D pattern in Fabric or Trevira CS+

Frame

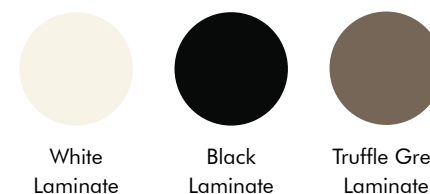

Plywood lining

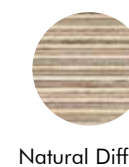

Door handle



Ventilation and lighting

Integrated LED light and ventilation controlled by a motion sensor.

Built-in castors

Allows BuzziNest to be moved around, without dismantling.

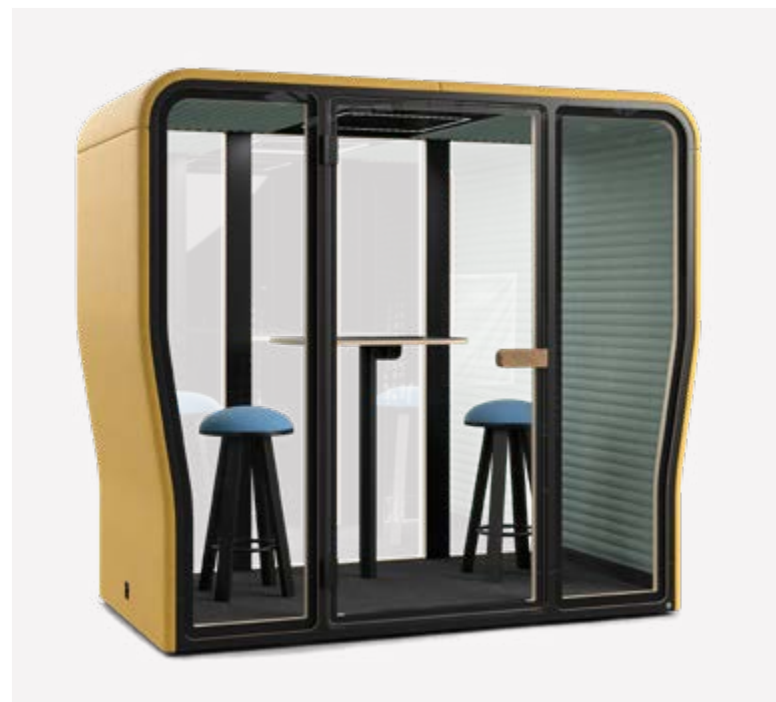

Add-ons



39 x 39 x 78 cm
15.35 x 15.35 x 30.71"

BuzziMilk Bar



39 x 39 x 47,5 cm
15.35 x 15.35 x 18.70"

BuzziMilk Stool

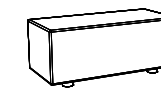

45.7 x 50 x 110 cm
18 x 19.7 x 43.31"

BuzziNest Cube



Shelf
70 x 29 cm | 27.55 x 11.4"
Height from floor: 105 cm | 41.34"



Low table
70 x 80 cm | 27.55 x 31.4"
Height from floor: 73.5 cm / 28.9"



High table
70 x 80 cm | 27.55 x 31.4"
Height from floor: 105 cm | 41.34"

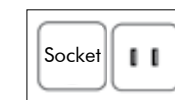

Electrification: 230 V, Twin
USB charger, type A & C,
max 5A at 5VDC combined
(only with shelf and table)

Tables and shelf

Finishes



Oak



White
Laminate



Black
Laminate



Truffle Grey
Laminate

Plywood lining

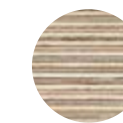

Natural Diffuse

Configurations with add-ons

BuzziNest Booth

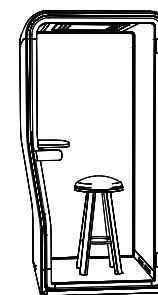

Right-handed with
shelf, electrification
and BuzziMilk Bar



Left-handed with
shelf, electrification
and BuzziMilk Bar

BuzziNest Pod

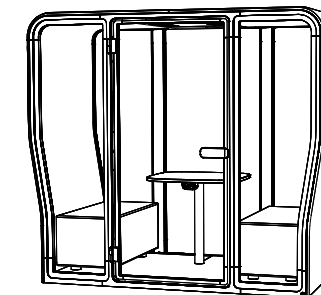

With low table, electrification and
2x BuzziNest Cubes

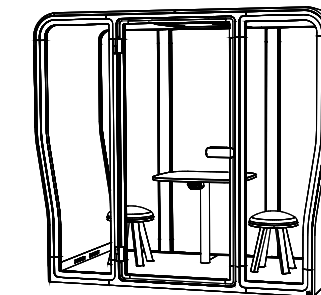

With low table, electrification and
2x BuzziMilk Stool

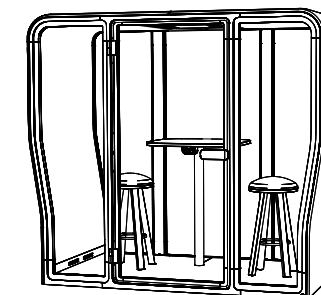

With high table, electrification and
2x BuzziMilk Bar

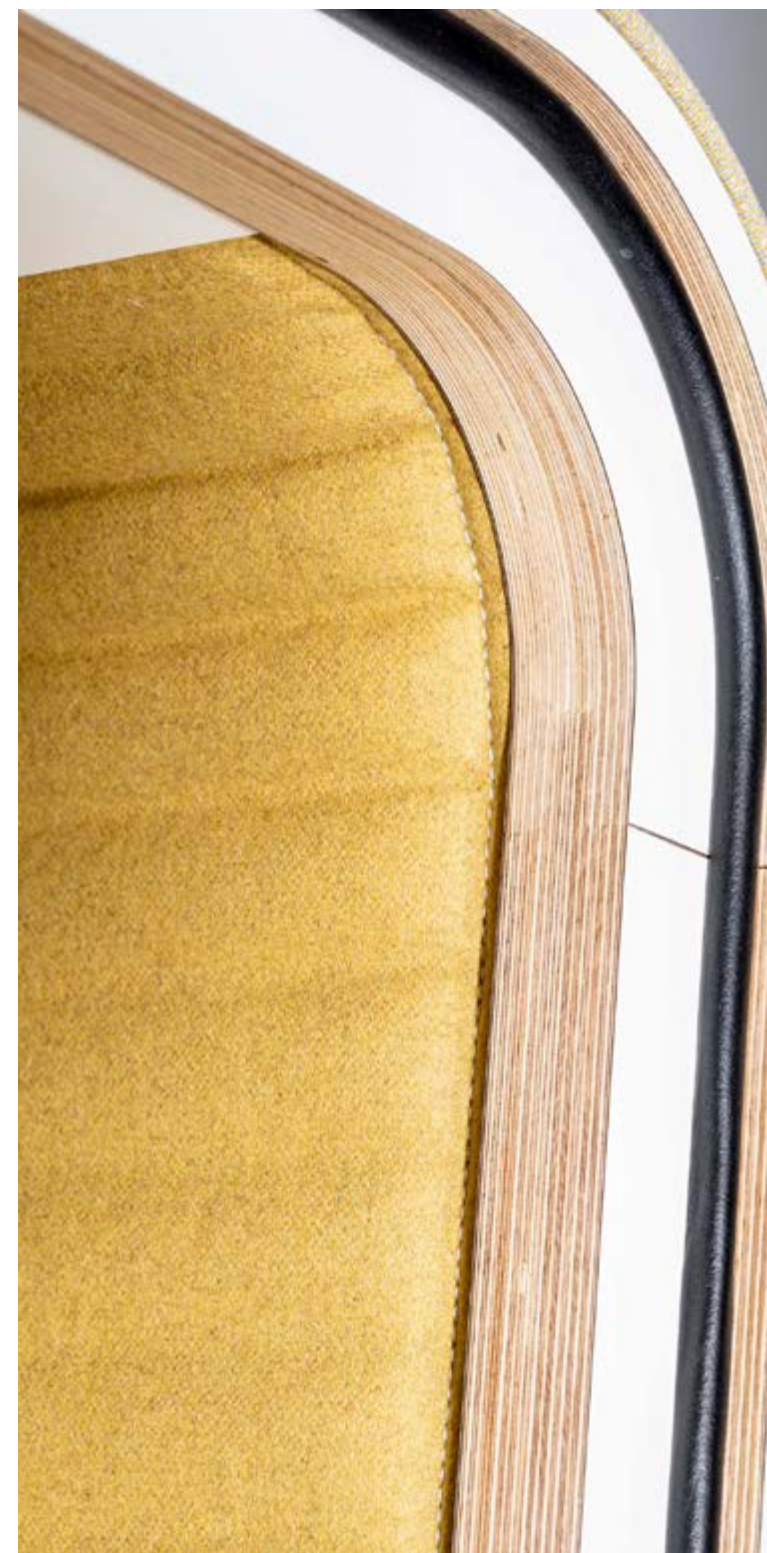

Acoustics

Acoustic Principles

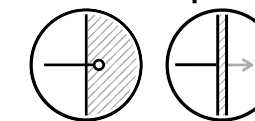

Absorption Attenuation

Acoustic Performance



Low Tones Mid Tones High Tones

How to order

Left or right handed, frame color, exterior fabric (CAT A > collection > color), interior finish (Felt, Felt Printed, 3D rib > color or print), shelf with electrification (finish), region

Need help? Contact BuzziSpace Project Care
project.care@buzzi.space



BuzziPouf

— by BuzziSpace Studio

A sound-absorbing element

BuzziPouf is available in a round or square shape and can be used as a seating element or as a side table. By choosing different fabrics from our collection, you can create a distinctive style.

Models & Patterns

Square

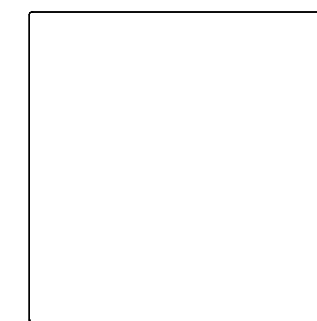

Round

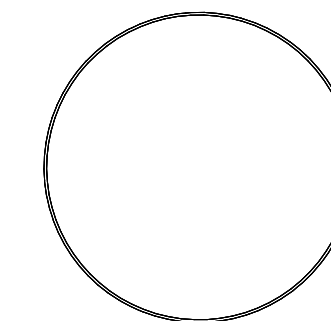

Square Flat

92 cm
36.22"

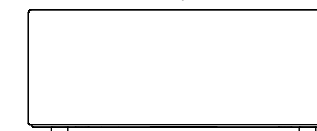

Round Flat

Ø 92 cm
36.22"



Square 3D

94 cm
37.08"

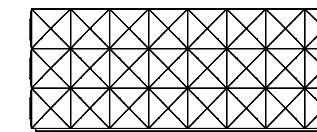

Round 3D

Ø 93 cm
36.61"

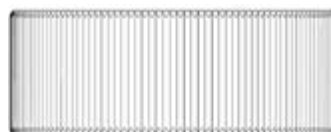

Finishes

Upholstery in fabric collections CAT A, B, C, D, E, F (check our application overview p. 330)

Acoustics

Acoustic Principles

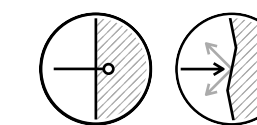

Absorption Diffusion

Acoustic Performance

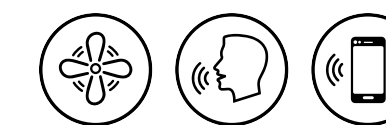

Low Tones Mid Tones High Tones

How to order

Model
Pattern
Fabric (CAT > collection > color)



BuzziPuzzle

— by BuzziSpace Studio

Sound-absorbing pouf

Interactive and playful, BuzziPuzzle is a one-of-a-kind BuzziSpace experience. BuzziPuzzle poufs fit together in a chain of sound-balancing seats that can go anywhere, from a break-out office space or kids' playroom.

Dimensions

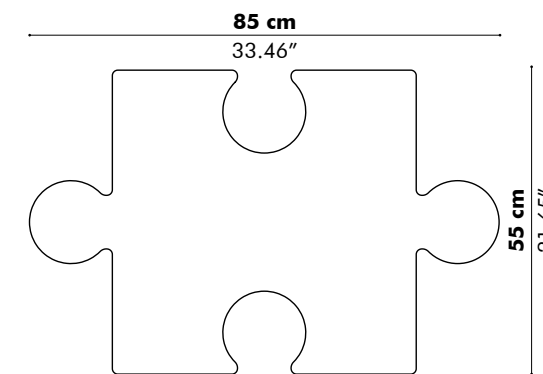

Low

Antiskid bottom

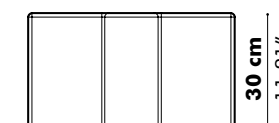

Wood bottom

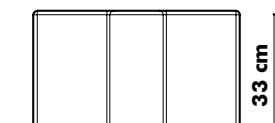

High

Antiskid bottom

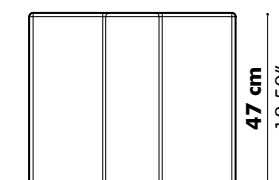

Wood bottom

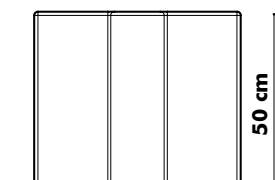

Finishes

Upholstery in fabric collections CAT A, B, C, D, E, F (check our application overview p. 330)
Bottom in antiskid or wood

Acoustics

Acoustic Principles

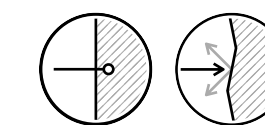

Absorption Diffusion

Acoustic Performance

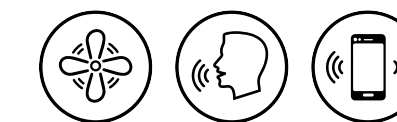

Low Tones Mid Tones High Tones

How to order

Model
Material
Fabric (CAT > collection > color)

BuzziRing

— by BuzziSpace Studio

A private space to get away

BuzziRing is the smallest work hub designed with contemporary workplaces and educational facilities in mind. On top of being an optimal wall-mounted solution for those seeking a private space for concentration and focus work, BuzziRing is a great place to take calls, hold video conferences, and also aids in creating zones in the workplace.



Dimensions

Side

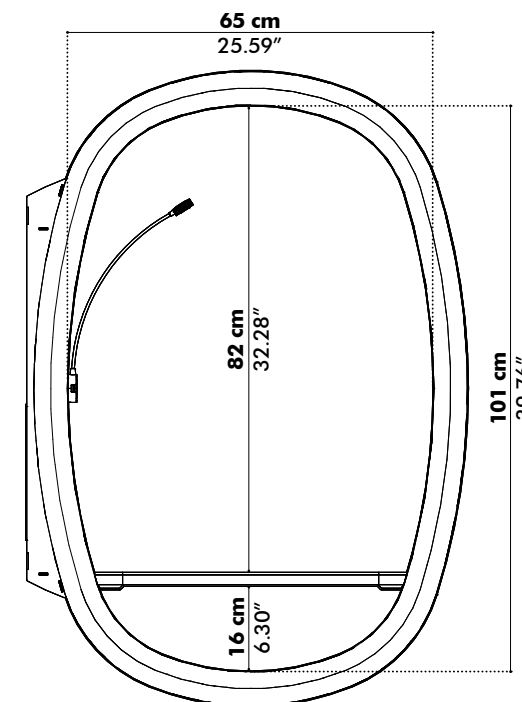

Width

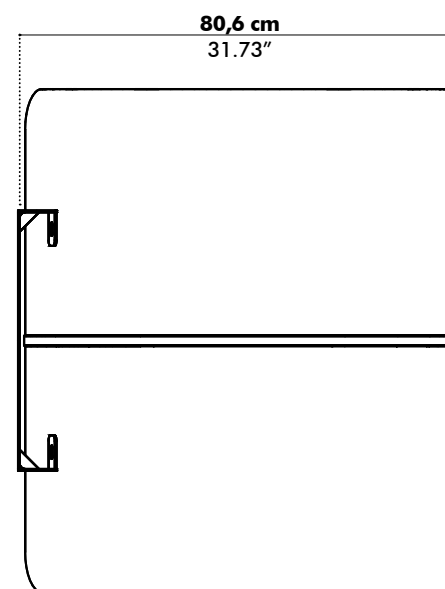

Finishes

Acoustic foam upholstered element in CAT A, B, C, D, E (check our application overview p. 330)
 Worktop: Antwerp oak, white laminate with birch multiplex core or melamine with fibre board core in black or white
 Wall connection: powder coated metal in black (RAL 9005)
 LED light in black aluminium with two USB chargers

Worktop & Shelves



Antwerp Oak



White Laminate

Options

Transparent screen in Green Cast® material

Acoustics

Acoustic Principles Acoustic Performance

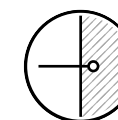

Absorption



Low Tones



Mid Tones



High Tones

How to order

fabric (CAT > collection > color), worktop material, color Melamine, power adapter (EU, UK or US), option

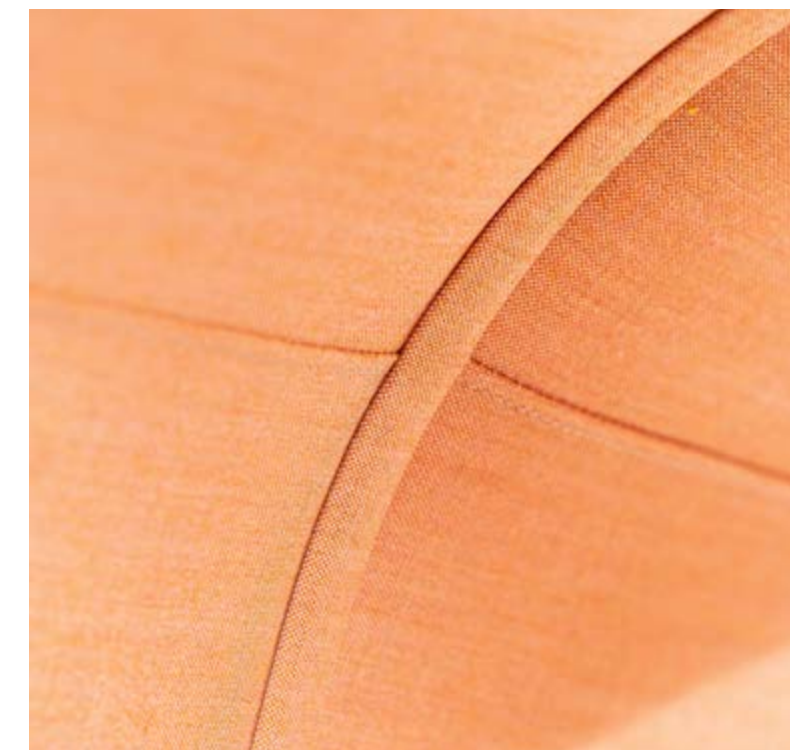

BuzziSpark

— by Alain Gilles

A private meeting space

BuzziSpark invites you to relax and observe in silence what happens in your surroundings. But it holds a surprise... Until you plunge yourself in its cocoon, you won't know 'who' or 'if' someone is sharing the same experience. You may run into another nomad with another story looking to escape from the everyday and make a new connection. The magic of BuzziSpark lies in the allure of the unknown – the surprise of not knowing who you'll meet around the corner.



Models

Original AG103 - Left open

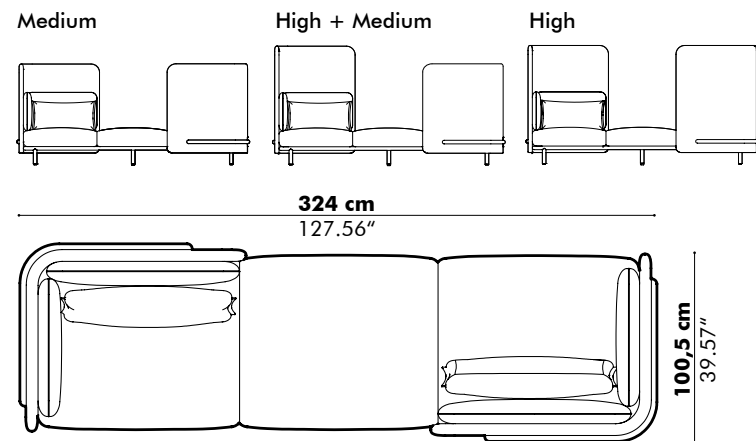

Original AG103 - Right open

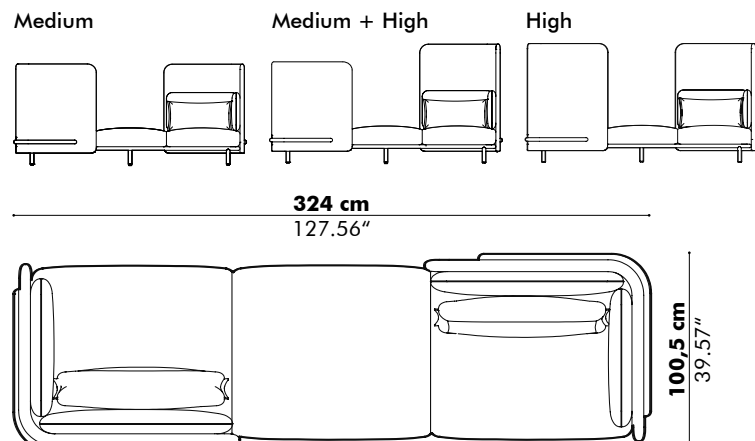

Original AG102 - Left open

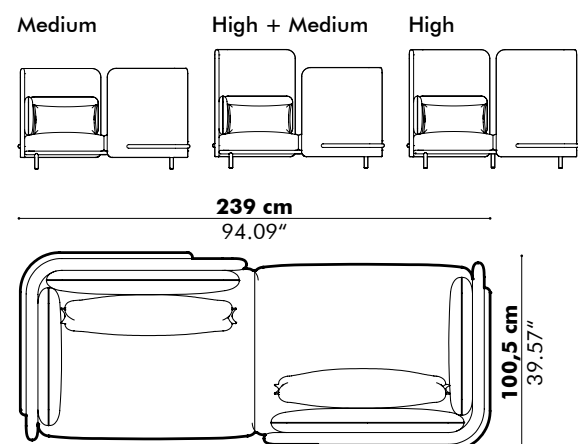

Original AG102 - Right open

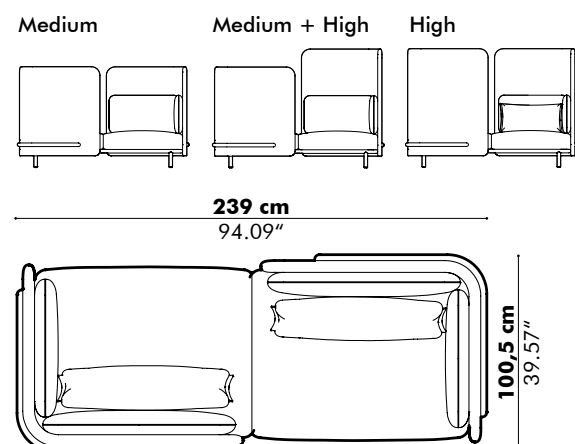

Sofa AG112

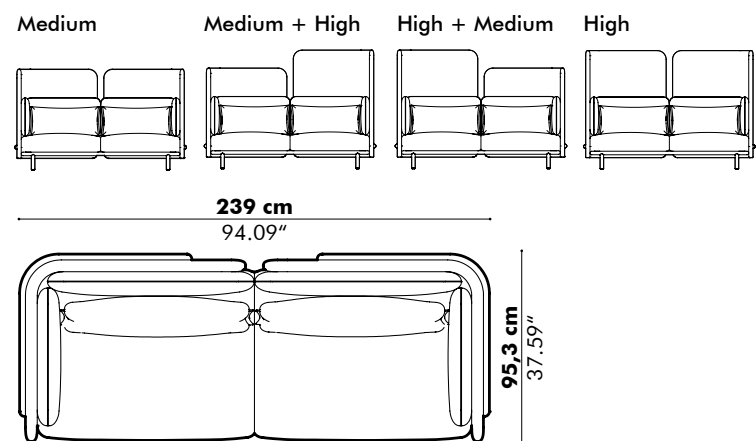

Sofa AG111

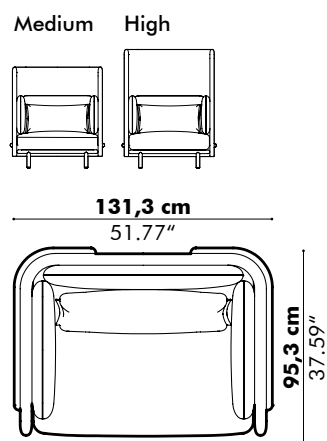

Components

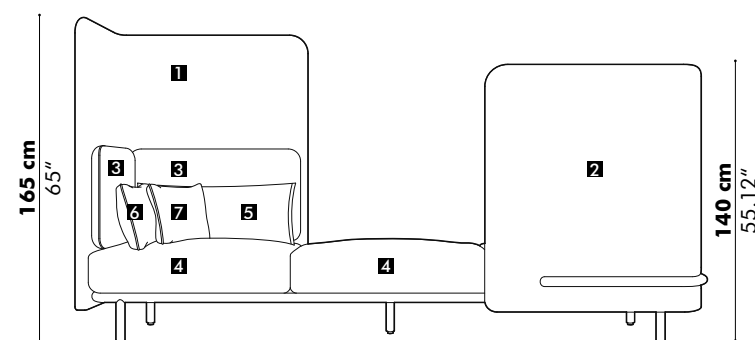

- 1 | Shield large
 - 2 | Shield medium
 - 3 | Shield cushion
 - 4 | Seating cushion
 - 5 | Comfort back
 - 6 | Comfort arm*
 - 7 | Decorative cushion*
- * Optional

Finishes

Frame powder coated metal in black (RAL 9005)
 Shields in CAT A, B, C, D, E, F
 Seating cushions in CAT A, B, C, D, E, F, Leather
 Comfort and decorative cushions upholstered in CAT A, B, C, D, E, F and Leather
 (check our application overview p. 330)



Acoustics

Acoustic Principles

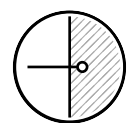

Absorption

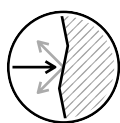

Diffusion

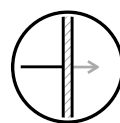

Attenuation

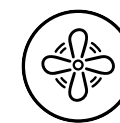

Low Tones



Mid Tones



High Tones

Acoustic Performance

Options

Tablet

Powder coated metal in black (RAL 9005) with worktop in Ash Black Stained

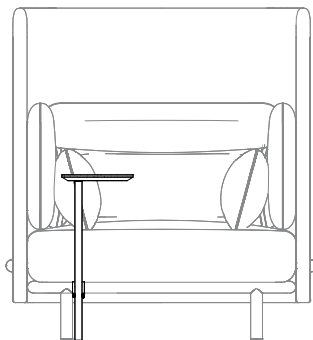

Electrification

3 m power cable included

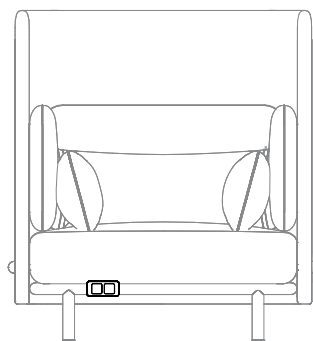

EU



Socket Type F, E or G + 2x USB port

US

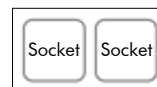

Socket Type B

Socket Type



Cushions

Comfort arm cushions (set of 2)

Decorative cushion

Anti-theft set for 2 cushions for decorative cushion or comfort arm cushion

How to order

Model

Size shields

Fabric shields (CAT > collection > color)

Fabric shield cushion & seating cushion (CAT > collection > color)

Fabric comfort back cushion & optional arm cushion (CAT > collection > color)

Options

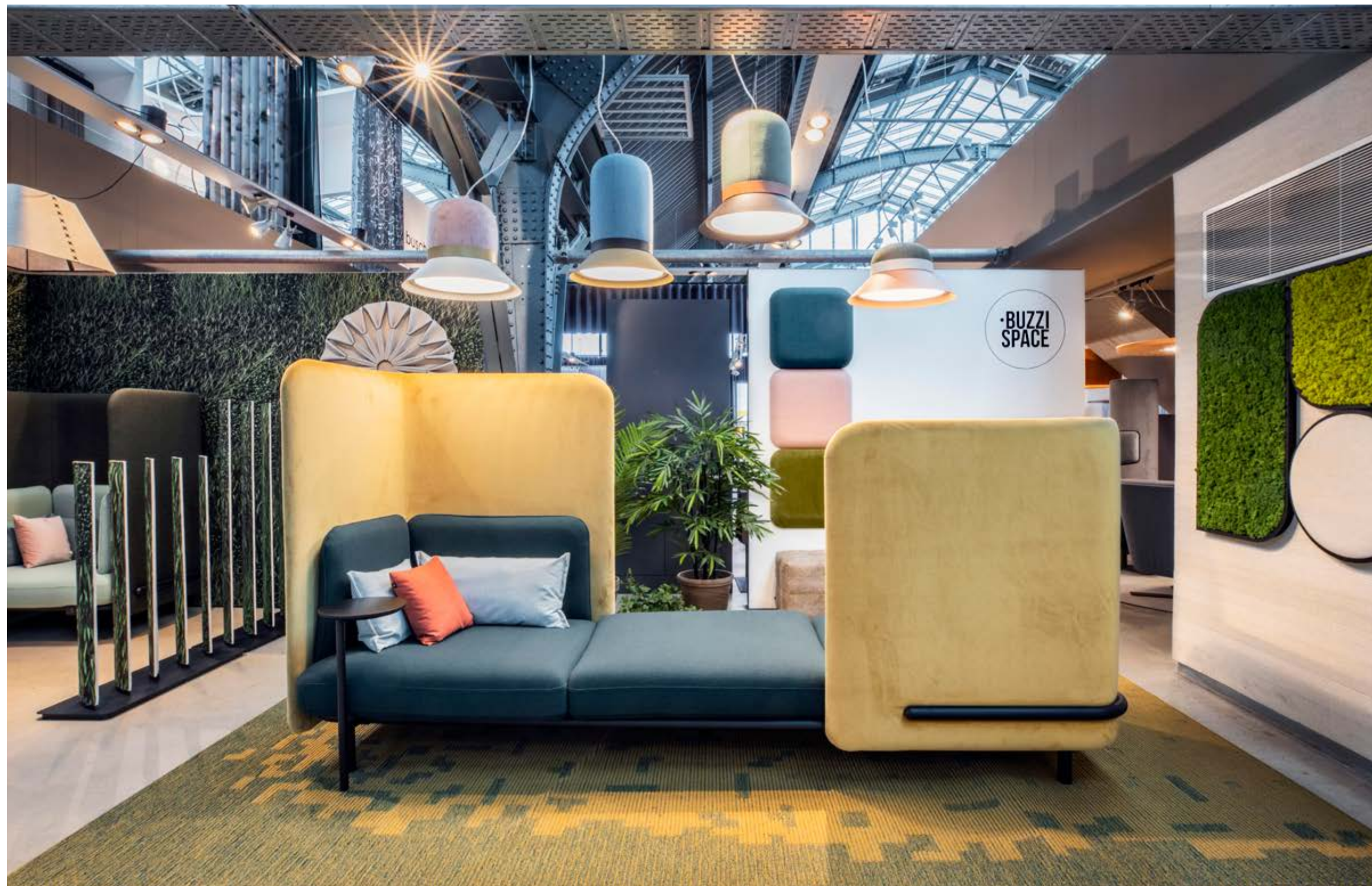



BMG Music - New York
Photography: Benny Chan

BuzziSpot

— by BuzziSpace Studio

A sound-absorbing and flexible round pouf

Meet the streamlined, curvy BuzziSpot: it cheers up any space. A light, fun, and sound-absorbing little ottoman that exists in a smooth Flat or 3D rib finish. The soft textile covering is blissful to sit on whatever you are doing.

Dimensions

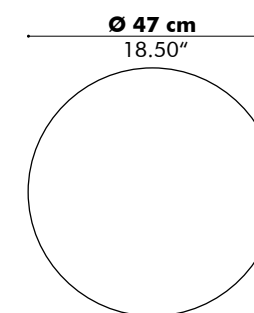

Patterns

Flat

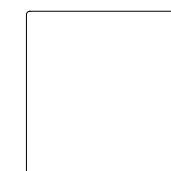

3D

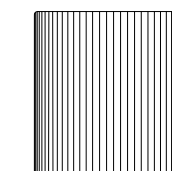

Finishes

Upholstery in fabric collections CAT A, B, C, D, E, F (check our application overview p. 330)

Bottom

AntiSkid

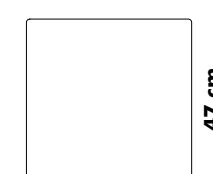

Wheels

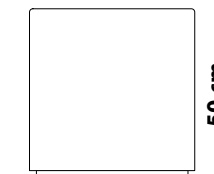

Wood

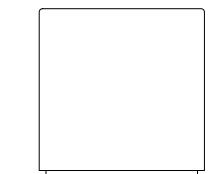

Acoustics

Acoustic Principles

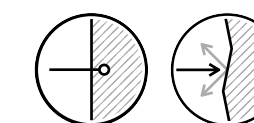

Absorption Diffusion

Acoustic Performance



Low Tones Mid Tones High Tones

How to order

Pattern

Bottom

Fabric (CAT > collection > color)



BuzziTemp

— by Alain Gilles

Temporary workstation

The BuzziTemp is a temporary workspace. The idea is to bring more dynamic to a space and allow the creation of small islands where people can come to connect or concentrate.

The straight sides create the possibility to generate straight office lines by using multiple BuzziTemp units together. At the same time it is offering you the necessary privacy whilst staying connected with the office environment.

Dimensions

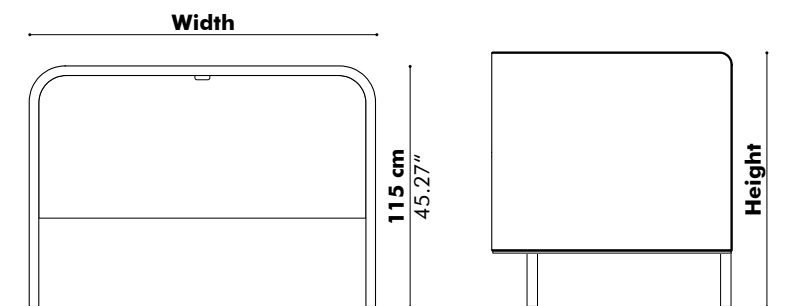

	Width		Height	
S	125 cm	49.21"	120 cm	47.24"
M	165 cm	64.96"	135 cm	53.15"
L	205 cm	80.71"		

Patterns

Flat

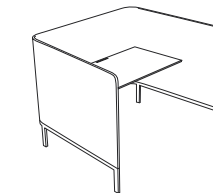

3D

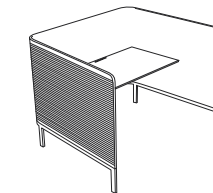

Finishes

Upholstery in fabric collections CAT A, B, C, D, E, F
(check our application overview p. 330)
Base powder coated metal in Umbra Grey (RAL 7022)

Options

Bicolor

Worktop in Antwerp Oak, with or without cable tray
LED light (only in combination with cable tray)
Set of alu brackets for customer-own worktop

Acoustics

Acoustic Principles

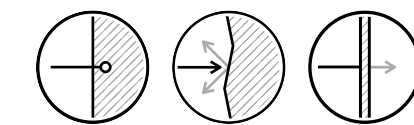

Absorption Diffusion Attenuation

Acoustic Performance

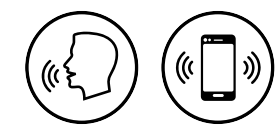

Mid Tones High Tones

How to order

Size (W x H)
Pattern
Fabric (CAT > collection > color)
Options

BuzziVille

— by Alain Gilles

Upholstered workstations

BuzziVille allows you to develop your own little village in the office. A flexible and modular freestanding system that can easily be rearranged to the needs of the office space. It's possible to have both public and private space, and even informal meeting rooms. Collaborate together or work independently, all within the easily movable urban workspace.



Predefined setups

Booth

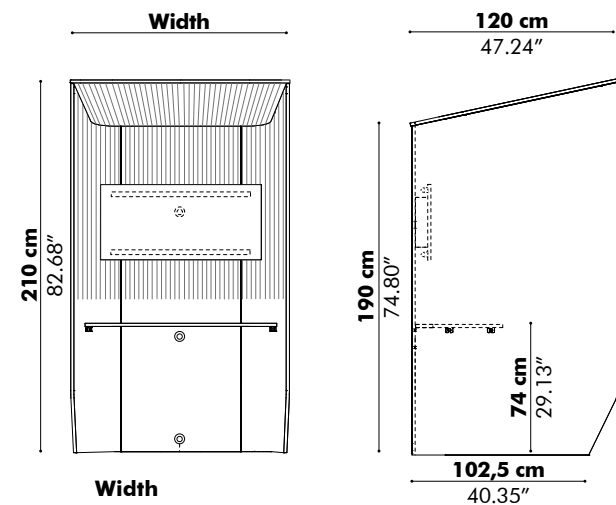

	Width	
S	130 cm	51.18"
M	170 cm	66.93"
L	210 cm	82.68"

Booth Standing

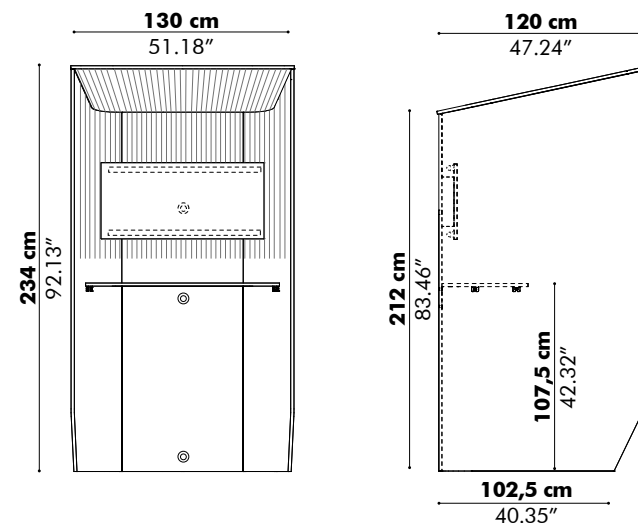

Hub

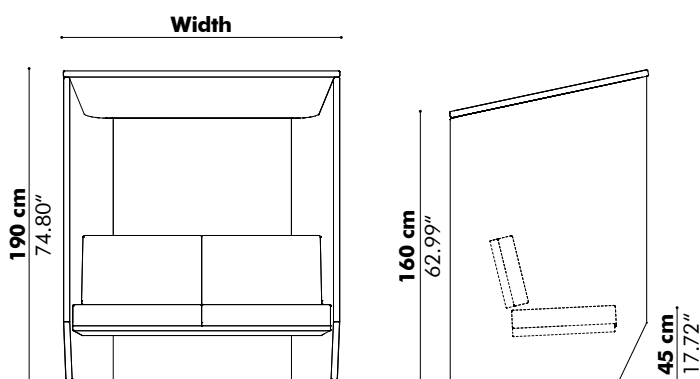

	Width	
S	130 cm	51.18"
M	170 cm	66.93"
L	210 cm	82.68"

Hub Open

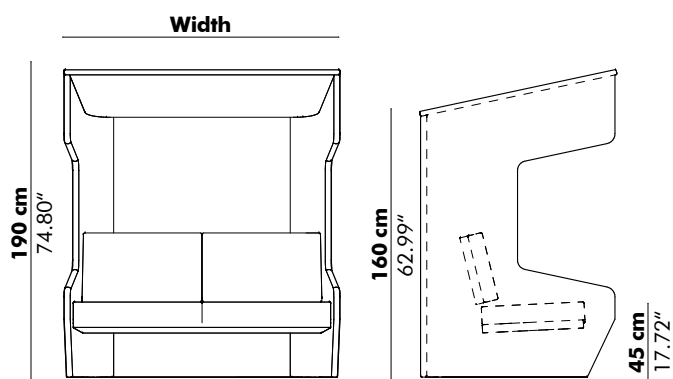

Finishes

Panels
Upholstery in fabric collection CAT A (check our application overview p. 330)

Worktops



Antwerp Oak



White Laminate

How to order

Model
Size
Fabric (CAT > collection > color)
Finish Worktop

Desk

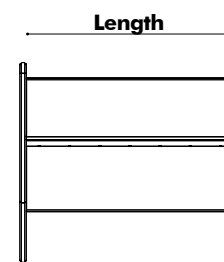
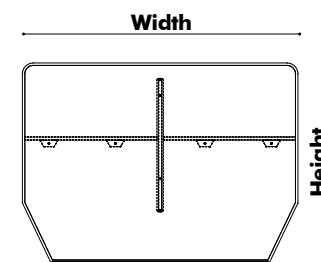

	Length	Width	Height
S	125 cm	49.21"	165 cm 64.96"
M	165 cm	64.96"	205 cm 80.71"
L	205 cm	80.71"	

Meet

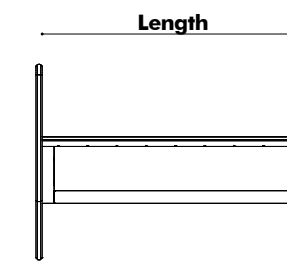
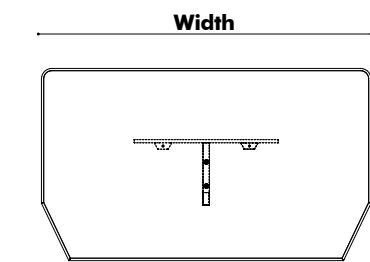

	Length	Width	Height
S	125 cm	49.21"	165 cm 64.96"
M	165 cm	64.96"	205 cm 80.71"
L	205 cm	80.71"	





Volkswagen Financial IT offices - Berlin
Photography: Andrea Janssen

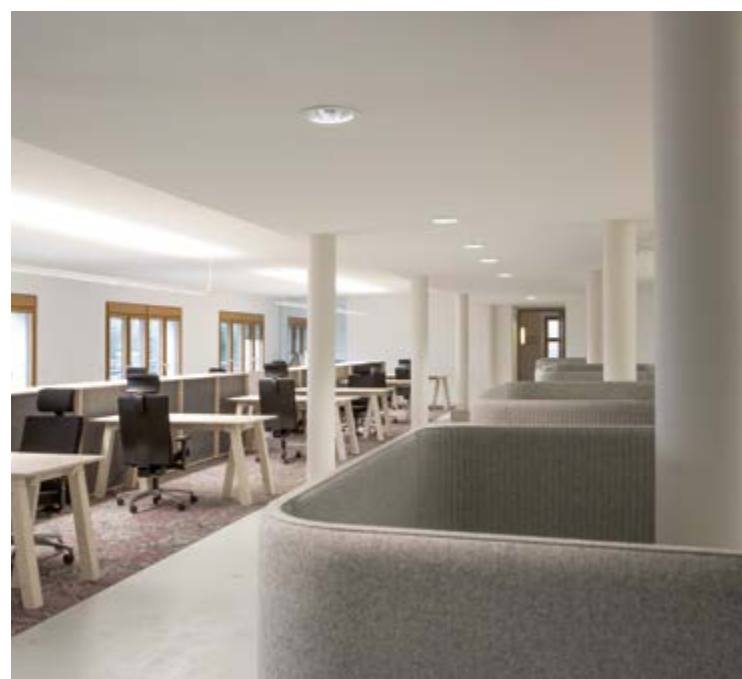

Inspiration Models

Let these inspiration models guide you when building your own BuzziVille setup. Dimensions of these predefined setups are dependent on the size of the panels you choose. All models are available in 4 heights: 120, 135, 150 & 180 cm | 47.24", 53.15", 59.06", 70.87"

Work

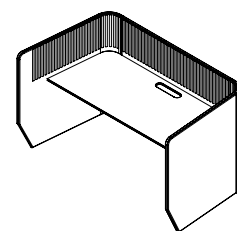

Snake

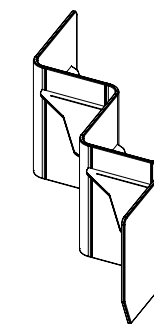

Focus

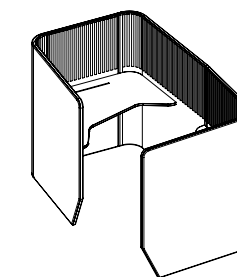

Club

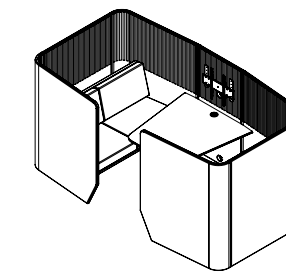

Cocoon

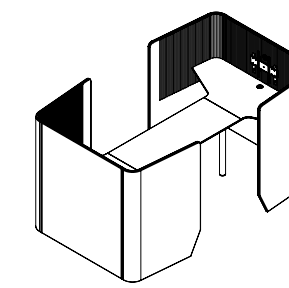

Panels

Start / Stop Left

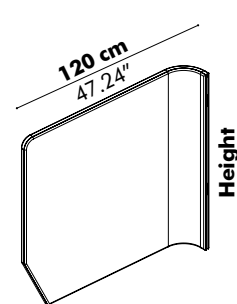

Start / Stop Right

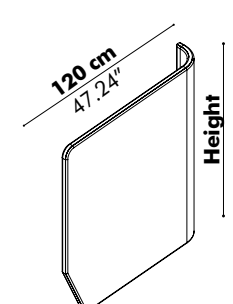

S-connect Left

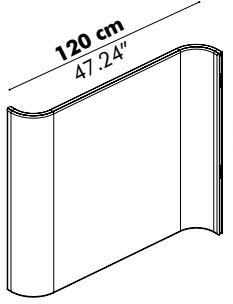

S-connect Right

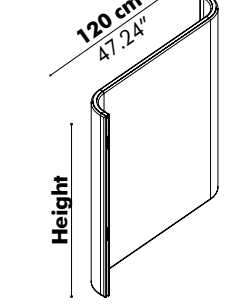

J-connect Left

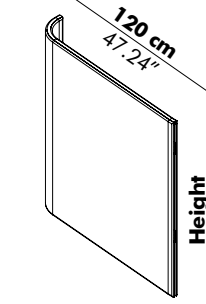

J-connect Right

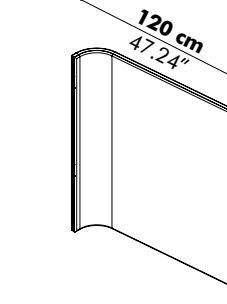

Mid

S

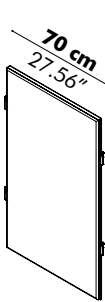

M

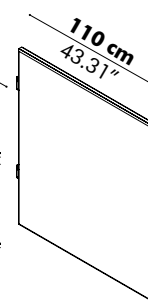

L

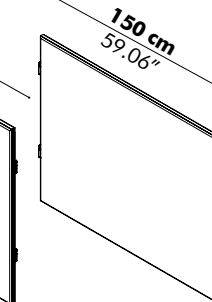

Mid Media

S

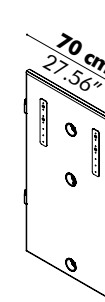

M

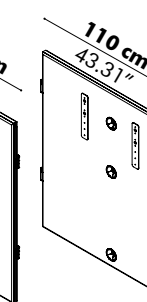

L

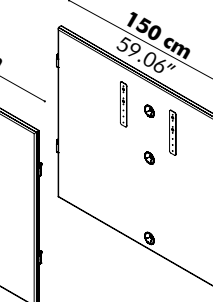

Height

120 cm	47.24"
135 cm	53.15"
150 cm	59.06"
180 cm	70.87"

Mid End

Left

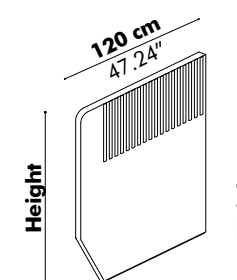

Right

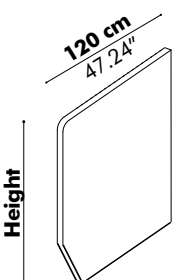

Finishes

Height 120 cm | 47.24"
Upholstery in fabric collections CAT A, B
Height 135 cm | 53.15" or larger
Upholstery in fabric collection CAT A
(check our application overview p. 330)

Patterns

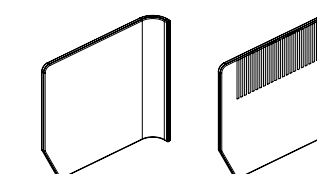

Flat

3D

Worktops

WT Club

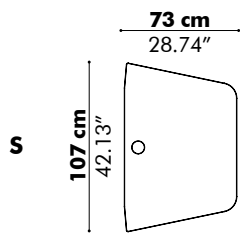

WT Cocoon

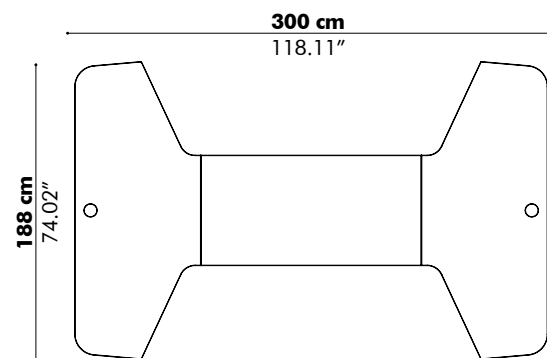

WT Flat

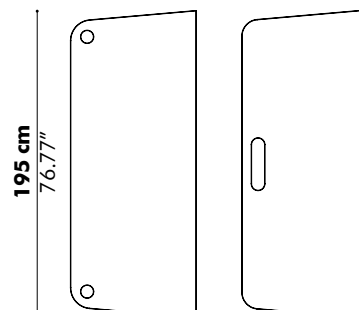
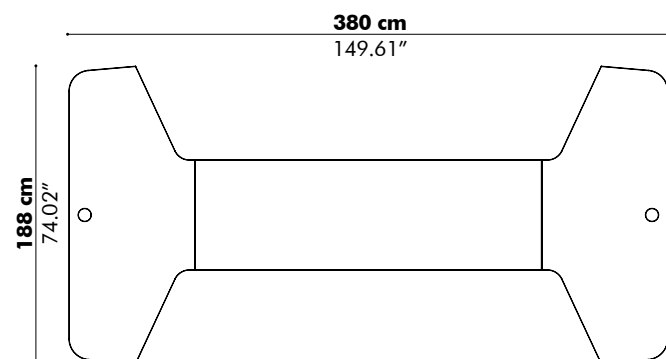
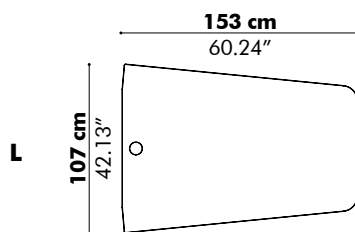
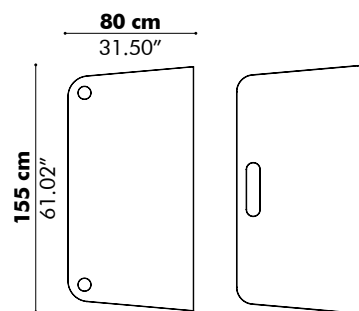
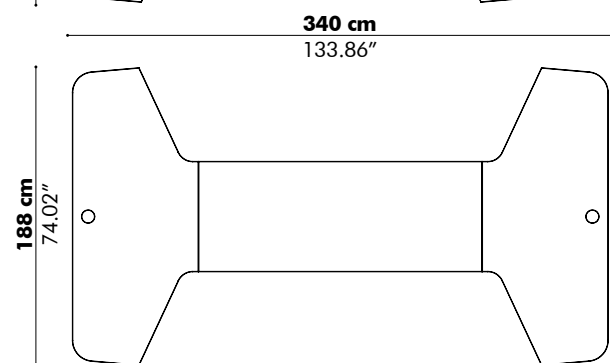
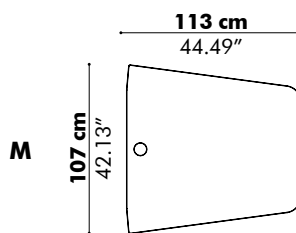
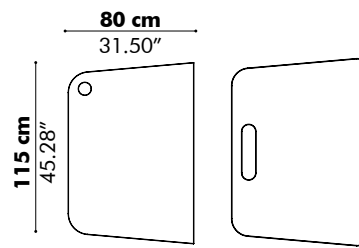

WT Shape

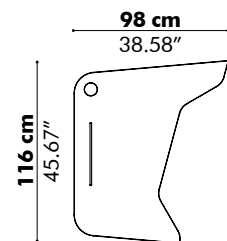

WT Triangle

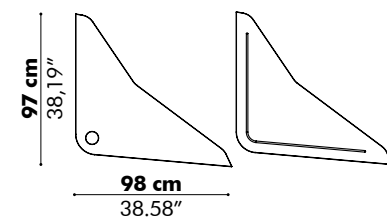
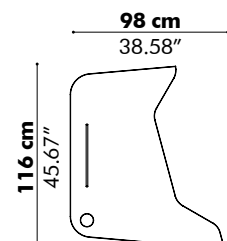
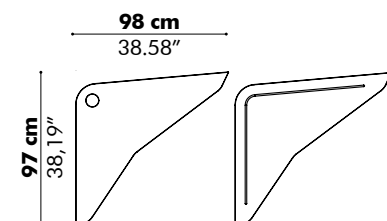

Finishes



Antwerp Oak

White Laminate

Cable entry 80 mm - 3.15" or 80 mm x 320 mm - 3.15" x 12.59"

Bench

S

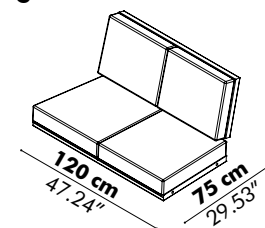

M

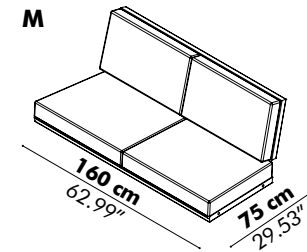

L

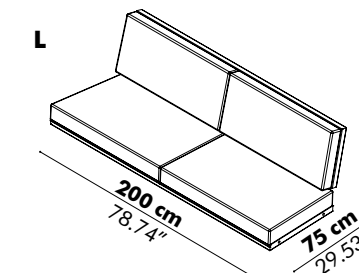

Finishes

Upholstery in fabric collections CAT A, B (check our application overview p. 330)

Tablet

S



M

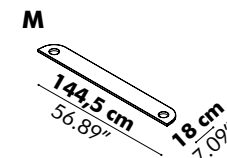

L

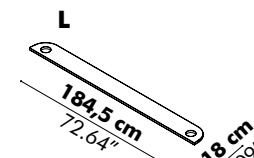

Finishes



Antwerp Oak

White Laminate

Split panel

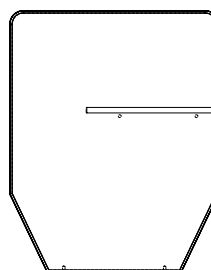
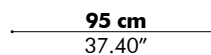

Height

120 cm	47.24"
135 cm	53.15"

Finishes

Upholstery in fabric collections CAT A, B (check our application overview p. 330)

Acoustics

Acoustic Principles

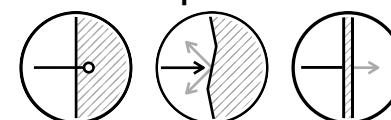

Absorption Diffusion Attenuation

Acoustic Performance

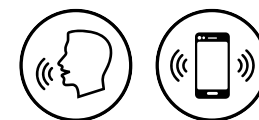

Mid Tones High Tones

Options

Electrification Unit

An electrification unit can be ordered for different regions.

- F
- E
- G
- B



Each electrification unit includes a HDMI, DATA and USB module. It can be configured (by the customer) by snapping HDMI, DATA and/or USB in the grey zone.

HDMI



DATA



USB

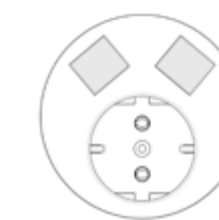

Backlight (LED)

How to order

Components
Size
Finish
Need help? Contact BuzziSpace Project Care

FURNITURE



BuzziBounce — 230



BuzziBox — 233

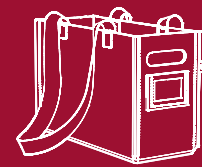

BuzziBox Travel — 235



BuzziCane — 236



BuzziFloat — 239

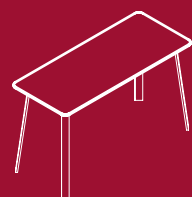

BuzziHub Table — 243



BuzziJungle — 245



BuzziMilk — 246

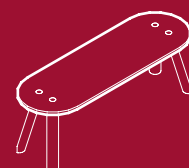

BuzziMilk Table — 251



BuzziMirage — 253

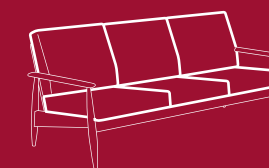

BuzziNordic ST100 — 254

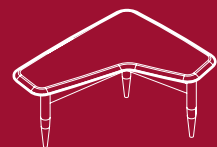

BuzziNordic ST400 — 257

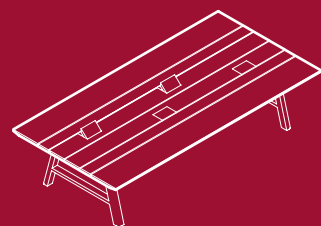

BuzziPicNic — 258

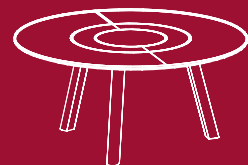

BuzziPicNic Round — 264



BuzziPlank — 267



BuzziSuzzi — 269

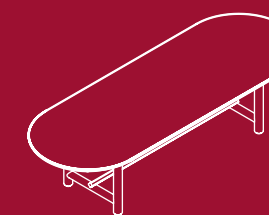

BuzziTable — 270

FURNITURE

BuzziBounce

— by Gerd Couckhuyt

The perfect chair to bounce back

BuzziBounce is a full-bodied seat on a flexible metal base that provokes a light spring-like effect when sitting. It is defined by its S-shape. Either a wooden finish or upholstery can be used as a highlight on the back of the chair. BuzziBounce brings movement into an otherwise static workday. Its mixture of materials and interactive design distinguishes it as an engineered, comfortable seating experience. BuzziBounce is ideal for offices or residential use.



Dimensions

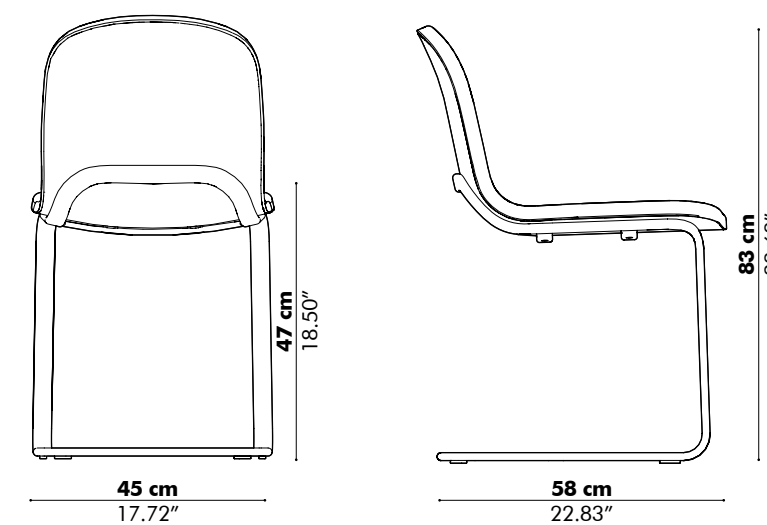

Finishes

Base in black satin or alu satin
 Seat upholstered in fabric collections CAT A, B, E
 (check our application overview p. 330)
 Back in 3D veneer (Ash White Wash or Ash Black Stained)
 or upholstered in CAT A, B, E
 (same collection as upholstery seat, different colors possible between back and seat)

How to order

Fabric seat (CAT > collection > color)
 Material back (Ash White Wash, Ash Black Stained or upholstered)





BuzziBox

— by BuzziSpace Studio

Storage box in BuzziFelt

The storage basket is made of 100% recycled BuzziFelt, available in different sizes and colors. It is the perfect storage solution for magazines, toys, papers or even laundry!

Dimensions

	Length	Width	Height
XXS	35 cm 13.78"	18 cm 7.09"	27 cm 10.63"
XS	35 cm 13.78"	25 cm 9.84"	27 cm 10.63"
S	35 cm 13.78"	35 cm 13.78"	35 cm 13.78"
M	40 cm 15.75"	60 cm 23.62"	40 cm 15.75"
L	45 cm 17.72"	65 cm 25.59"	45 cm 17.72"
XL	50 cm 19.69"	70 cm 27.56"	50 cm 19.69"

Finishes

BuzziFelt

How to order

Size
BuzziFelt color



BuzziBox Travel

— by BuzziSpace Studio

BuzziBox Travel for the professional nomad

Use it as your personal travel box to store office supplies or personal belongings, get organized in your car or pack up your sports gear. To make sure nobody runs off with your bag, you can personalize it thanks to the adjustable name tag. This soft travel box is made of 100% recycled BuzziFelt and available in different colors to match your style. Bon voyage.

Dimensions

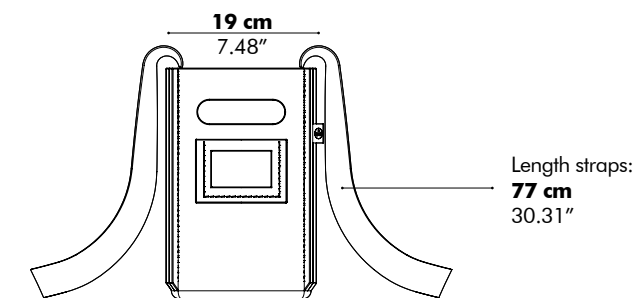
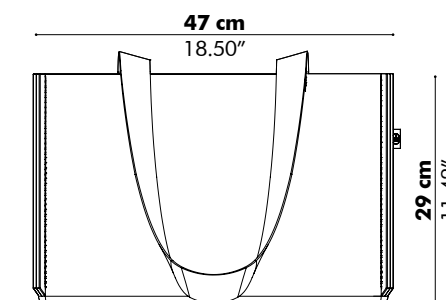

Finishes

Box in BuzziFelt
Strap: outside grey, inside black
Removable tag in BuzziFelt

How to order

BuzziFelt color



BuzziCane

— by Wiebe Boonstra & Marc van Nederpelt

A soft lounge sofa on an unexpected frame

With its woven cane back, wood base, and luscious upholstery, BuzziCane sofa brings a fresh, vintage-inspired look into the contemporary workplace. This sofa mixes a firm, elevated structure with plush seat and back cushions that are perfect for relaxing. The informal design welcomes guests with its friendly feel. BuzziCane is ideal for hotel suites, private offices, and homes. It is available as a one, two, or three-seater.



Dimensions

DO 101

Side view

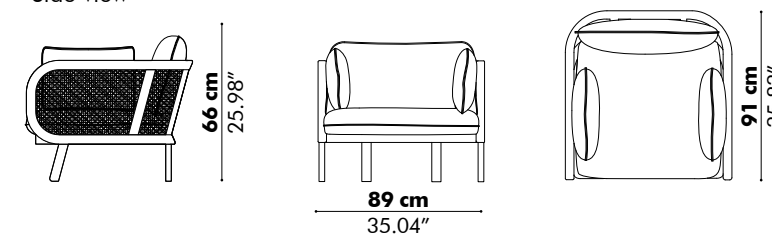

DO 102

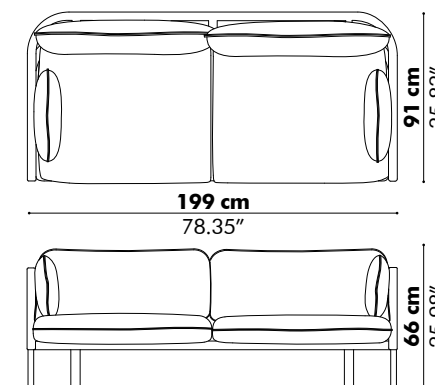

DO 103

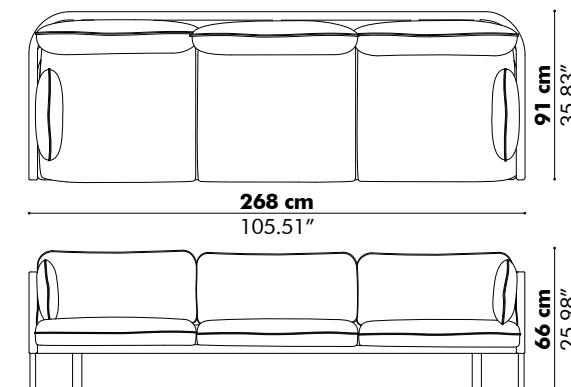

Finishes

Frame

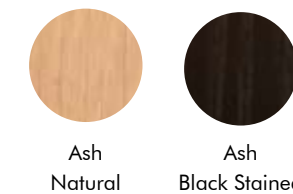

Webbing in Natural Rotan
 Cushions in fabric collections CAT A, B, C, D, E, F
 (check our application overview p. 330)

How to order

Model
 Color frame
 Fabric (CAT > collection > color)



BuzziFloat

— by Alain Gilles

A minimal chair to maximize space

BuzziFloat is an intentionally simple design that blends into its surroundings. This transparent chair is engineered to feel spacious and airy and has a strong graphic personality. BuzziFloat is offered in multiple finishes: non-upholstered or upholstered with an elegantly cushioned seat and backrest. The bent plywood back support aligns perfectly with your tabletop. BuzziFloat fits perfectly together with BuzziPicNic tables in office settings, residential homes, and hospitality areas.



Models

Float

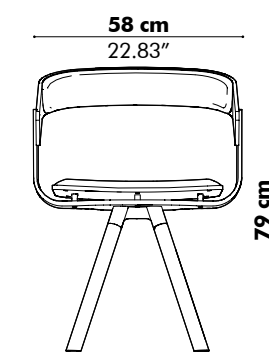

Float Cross

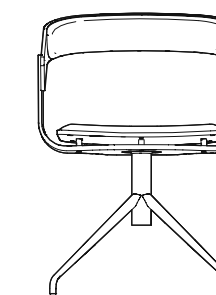

Float CrossPlus

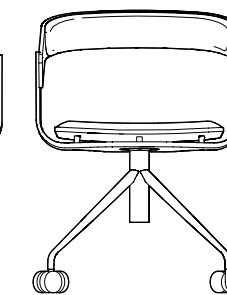

51 cm 20.08"

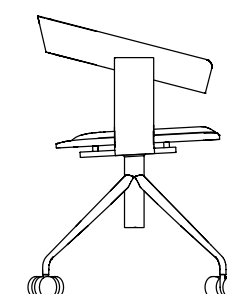
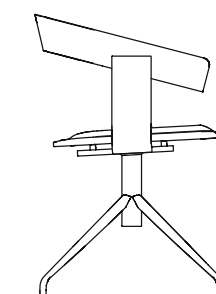
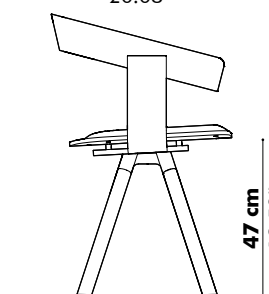

Finishes

Shell in Ash White Wash or Ash Black Stained - plain or with upholstered cushions in fabric collection CAT A, B, C, D, E, F, Leather (check our application overview p. 330)

Base Float in Ash White Wash or Ash Black Stained (same as shell)

Base Float Cross in black satin or alu satin

Base Float CrossPlus in black satin or alu satin

How to order

Base:

- Model

- Color

Finish shell

Fabric cushion (CAT > collection > color) or not upholstered



BuzziHub Table

— by Alain Gilles

Aluminum table

The BuzziHub Table is originally designed in combination with the BuzziHub but it can stand perfectly on its own. It is available in various sizes and is ideal as an office desk or as a small side table for your work gear.

Dimensions

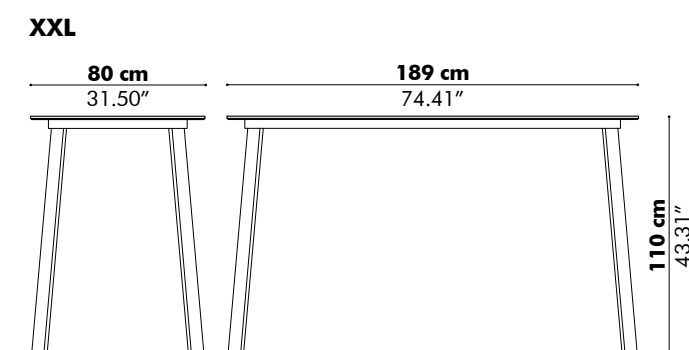
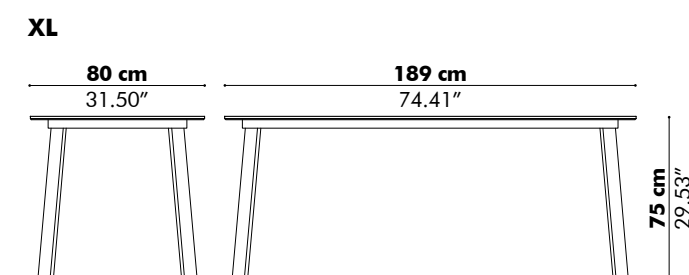
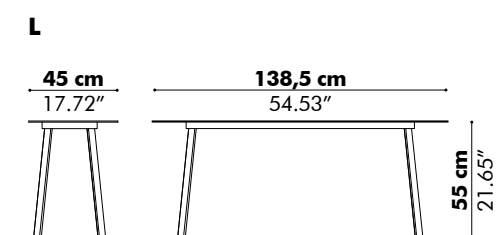
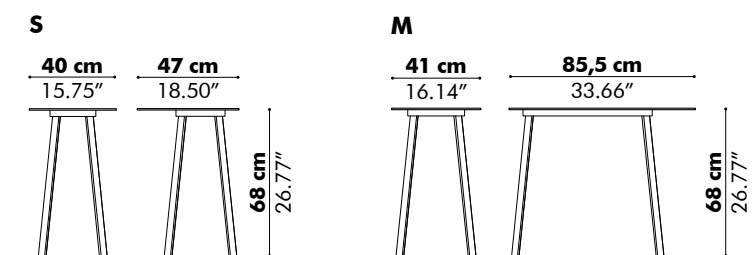

Finishes

Powder coated aluminum in black (RAL 9005) or white (RAL 9010)

How to order

Size
Color



BuzziJungle

— by Jonas Van Put

Vertical conversation tower

Inspired by nature, BuzziJungle offers a solution to the conventional meeting space. The launch of the BuzziJungle introduced the design world to young Belgian talent Jonas Van Put. This is Van Put's first project with a major international manufacturer. BuzziJungle is BuzziSpace's reflection of their vision for the social office and further pushing the traditional boundaries of the workplace.

Various elements within the structure provide an opportunity for different interactions within the "jungle". You can climb, lounge and meet in the elevated work-lounge space made from powder coated steel. The BuzziJungle creates an urban footprint in large and small spaces.

Models

The Tower High

Overview

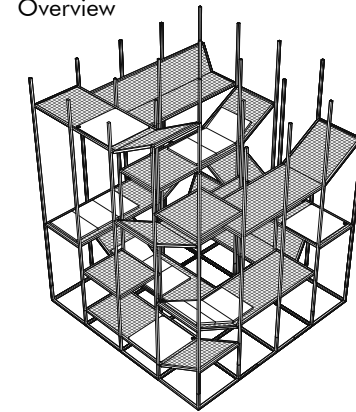

Side view

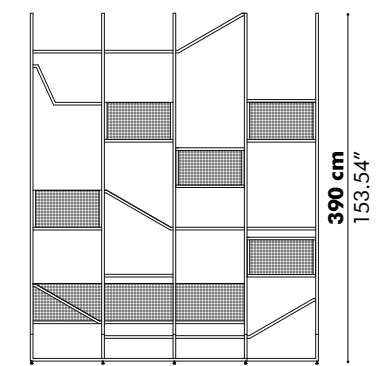

80 cm 80 cm 80 cm 80 cm
31.50" 31.50" 31.50" 31.50"

323 cm
127.17"

390 cm
153.54"

The Tower Low

Overview

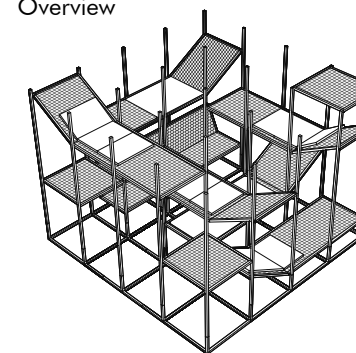

Side view

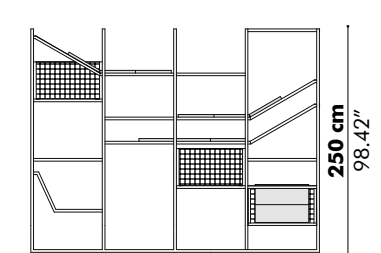

80 cm 80 cm 80 cm 80 cm
31.50" 31.50" 31.50" 31.50"

323 cm
127.17"

250 cm
98.42"

Finishes

Powder coated metal frame in Fluo Yellow (RAL 1016)
Seats, beds, tablets (frame + mesh) in galvanized metal
Cushion upholstered in fabric CAT A

How to order

Model
Cushions



BuzziMilk

— by Alain Gilles

A classic milk stool

This rustic-meets-modern take on the old farmhouse favorite would even make your grandma feel nostalgic. BuzziMilk is a sturdy little stool inspired by elements not usually found in a standard office space. Its goal? Create a warm and homey feeling at work.

BuzziMilk has four legs and an upholstered seat for a softer experience. Select from a variety of wood finishes and make it your own by pairing with one of our many BuzziSpace fabrics. Whether you choose a bold pop of color (red, yellow, green, white and blue) or a natural neutral, it is designed to stand on its own or match the BuzziPicNic table.

Looking for a pure wood stool? BuzziMilk Stool AllWood is pure simplicity and strong design.



Models

Stool

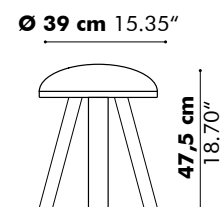

Counter

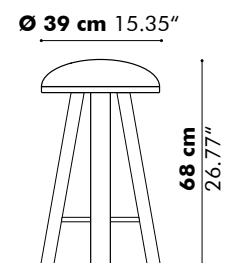

Bar

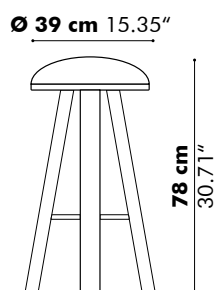

Bench

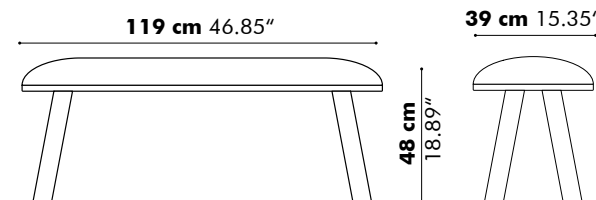

Stool All Wood

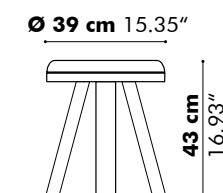

Tile Small

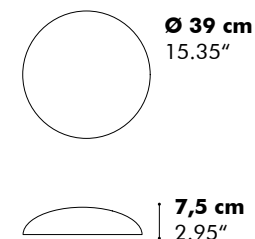

Tile Large

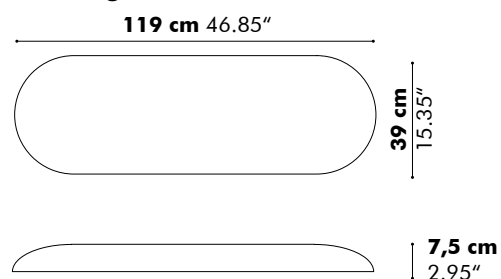

Finishes

Frame



Seating upholstery in fabric collections CAT A, B, C, D, E, F & Leather (check our application overview p. 330)

How to order

Model
 Wood finish (not for tiles)
 Fabric (CAT > collection > color)
 Bench Tartan: straight or diagonal orientation fabric





BuzziMilk Table

— by Alain Gilles

A versatile little table

The BuzziMilk base has inspired the handy BuzziMilk Tables. They can be grouped together to create a series of coffee or side tables, or used independently. Like the BuzziMilk design, multiple size and color options are possible.

Models

Side Table

Ø 39 cm
15.35"

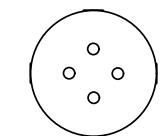

20 mm
0.79"

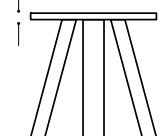

Side Table Large

119 cm
46.85"

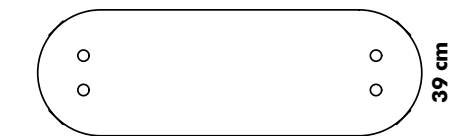

20 mm
0.79"



Table

Ø 100 cm
39.37"

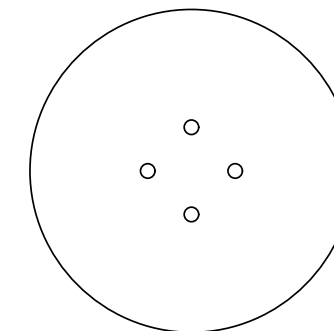

35 mm
1.38"

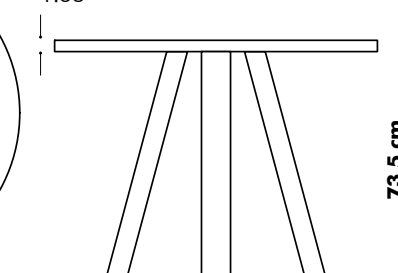

Finishes

Wood finish



Ash Natural Ash Black Stained Ash White Wash Walnut Oak

Not available in Ash Lacquered

How to order

Model
Wood finish



BuzziMirage

— by Alain Gilles

The Art of Illusion

BuzziMirage is about reflections, false perspectives and fake shadows. The mirrors act as a “trompe l’oeil” since they are based on false impressions and confused perceptions. “It’s a discussion between materials, reality and virtuality. But, above all BuzziMirage is about creating a little world of its own,” says designer Alain Gilles.

The offset between the arch-shaped mirror and its support creates a sense of depth and false impression that a door or window is open. The design combines various materials—a metal or wooden arched frame, paired with a glass mirror—to play with depth and light, creating new vanishing points.

Models

M

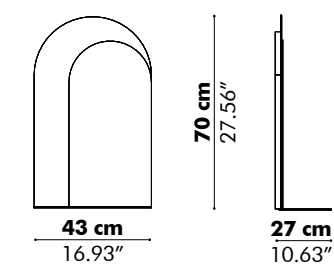

L

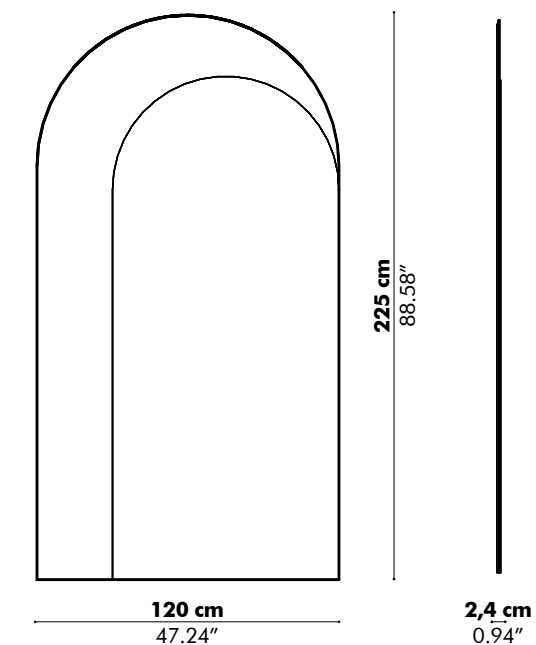

Finishes

M: Powder coated metal in Signal Grey (RAL 7004), Beige Red (RAL 3012), Black Green (RAL 6012) or Black (RAL 9005)

L: Wood veneer in Ash Black Stained or Ash White Wash

How to order

Size
Color

BuzziNordic ST100

— by Ståffan Thomassen

Lounge chair with Nordic heritage

The timeless look of Scandinavian furniture inspired the BuzziNordic Series. Model ST101 is a sleek armchair with a vintage look. The Nordic-inspired armchairs are available in plenty of different solid wood finishes. The homey feel of the armchairs is an ideal match for new BuzziSpace fabrics from Kvadrat. Discover the magic!



Kienbaum Offices - Cologne
Photography: Philipp Jester

Models

ST101



ST102

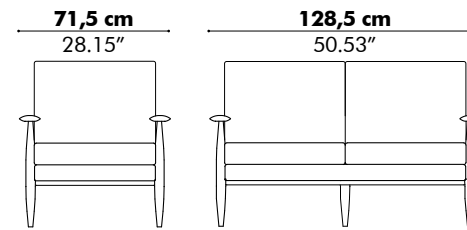

ST103

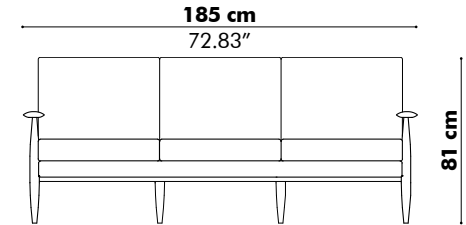

ST101 Ottoman

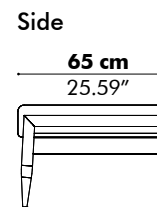
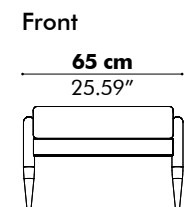

ST101 Footstool

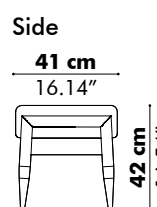
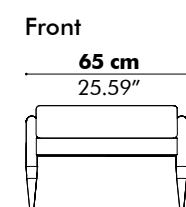

ST111

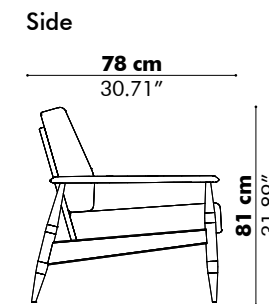
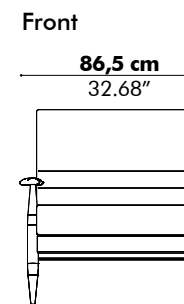

ST111 Ottoman

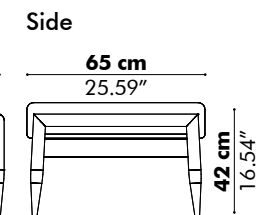
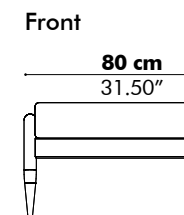

Finishes

Frame



Ash Natural Ash Black Stained Ash White Wash Walnut Oak



Ash Lacquered
White

Cushion in fabric collections CAT A, B, C, D, E, F, Leather
(check our application overview p. 330)

How to order

Model
Wood finish frame
Fabric (CAT > collection > color)





BuzziNordic ST400

— by Ståffan Thomasen

The guards of our BuzziNordic collection

The shapes allow you to position the side table left or right next to your sofa. Perfect for your evening tea, the daily newspaper or a table lamp. Our solid wood finish goes hand in hand with the brass cross. The perfect setting for a Mad Men scene.

Models

ST401

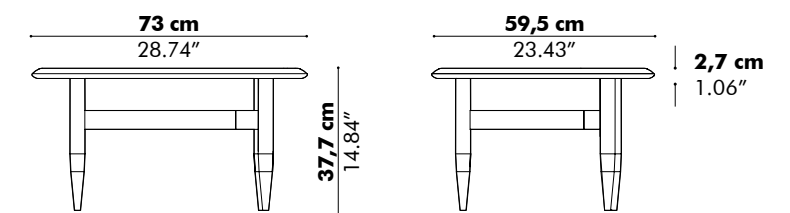

ST401 Left

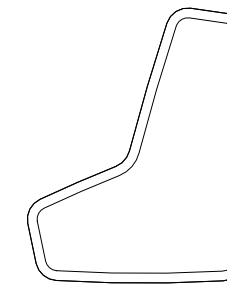

ST401 Right

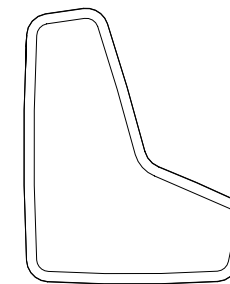

Finishes

Legs and Tabletop



Ash
Black Stained

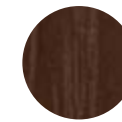

Walnut

Connection part in brass

How to order

Model
Wood finish



BuzziPicNic

— by Alain Gilles

The first indoor picnic table

Go ahead, have a picnic in the office! Now you can work, have a meeting, stop for lunch or enjoy a beer with your coworkers at the same multifunctional table. Open the windows and get the barbecue going!



Models

Desk

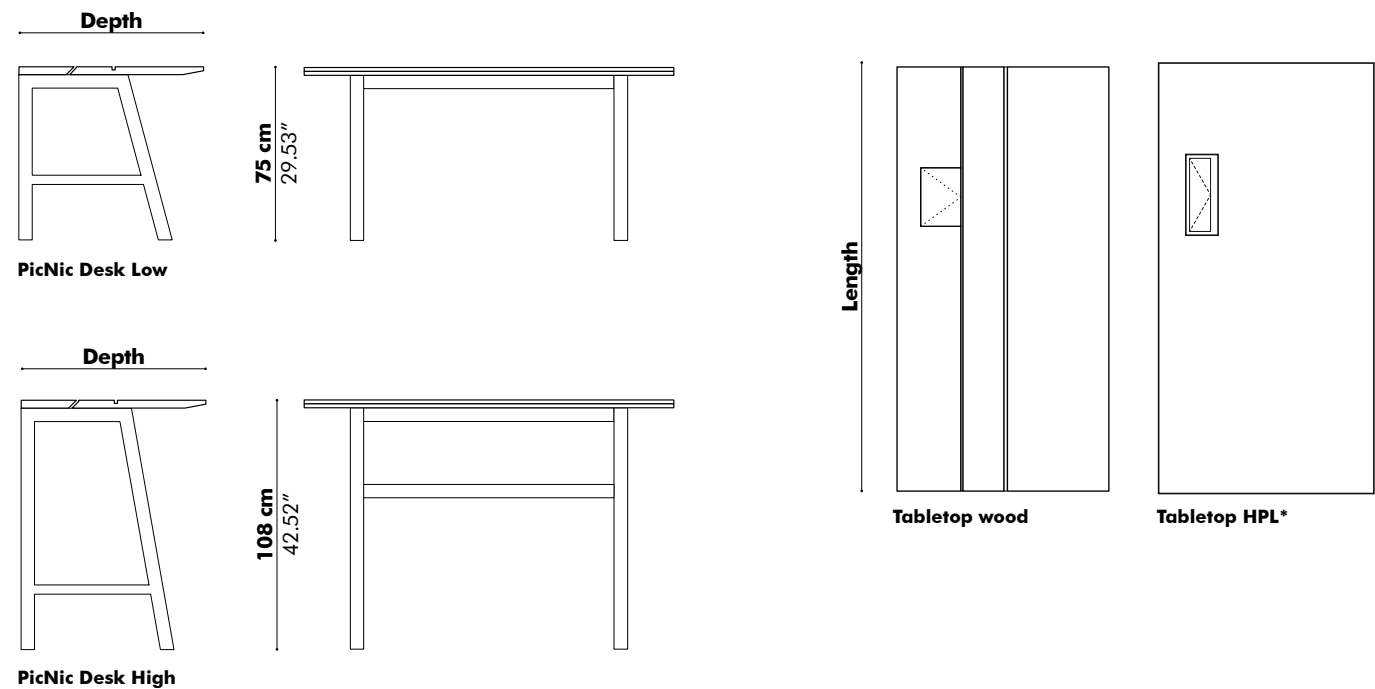

Length 120 cm 47.24" 140 cm 55.12" 160 cm 62.99" 180 cm 70.87" 200 cm 78.74" 220 cm 86.61" 240 cm 94.49"
Depth 80 cm 31.50" 90 cm 35.43" 100 cm 39.37"

* HPL worktop always without grooves

Meet

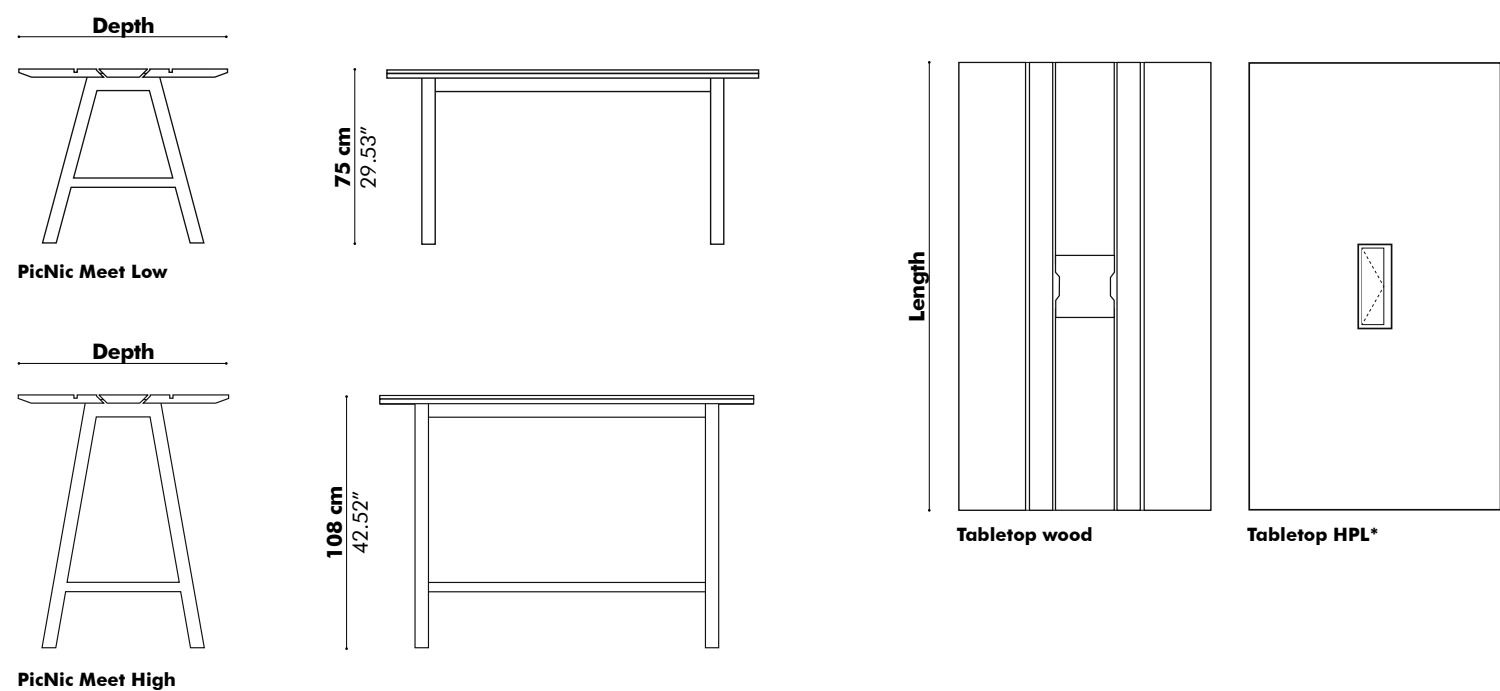

Length 160 cm 62.99" 180 cm 70.87" 200 cm 78.74" 220 cm 86.61" 240 cm 94.49"
Depth 80 cm 31.50*** 90 cm 35.43" 100 cm 39.37" 120 cm 47.24"

* HPL worktop always without grooves
 ** 80 cm - 31.50" only available for Meet High. Cable entry not possible.

Side

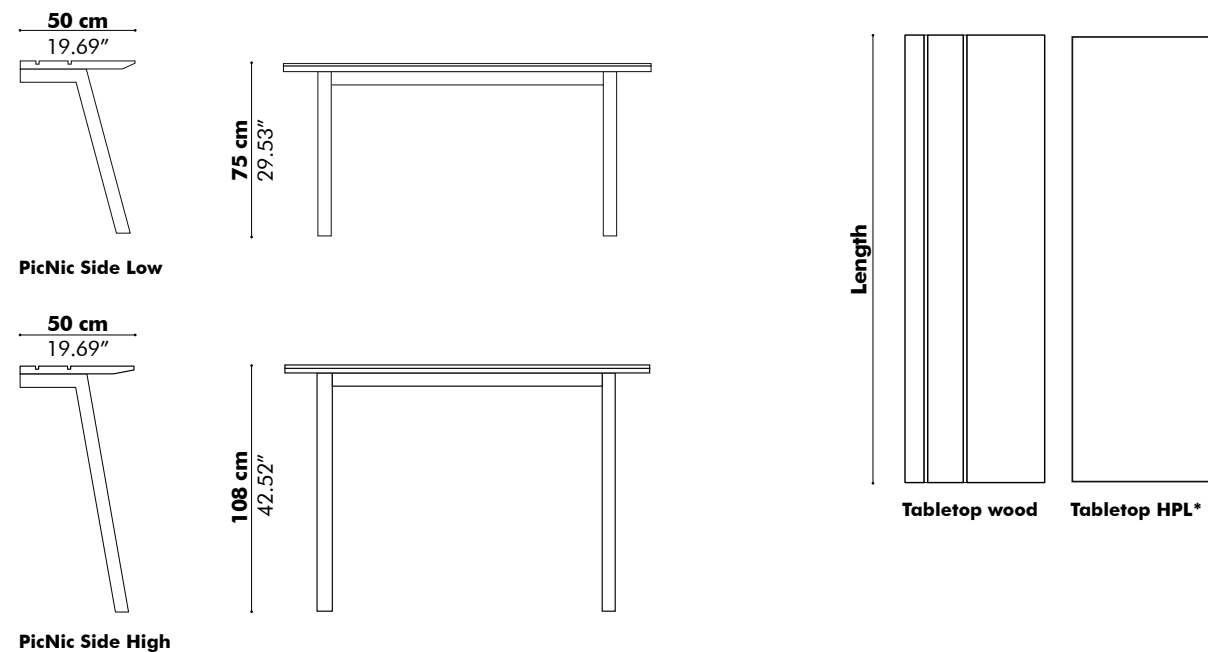

Length 160 cm 62.99" 180 cm 70.87" 200 cm 78.74" 220 cm 86.61" 240 cm 94.49"
Depth 50 cm 19.68"

* HPL worktop always without grooves

WorkBench

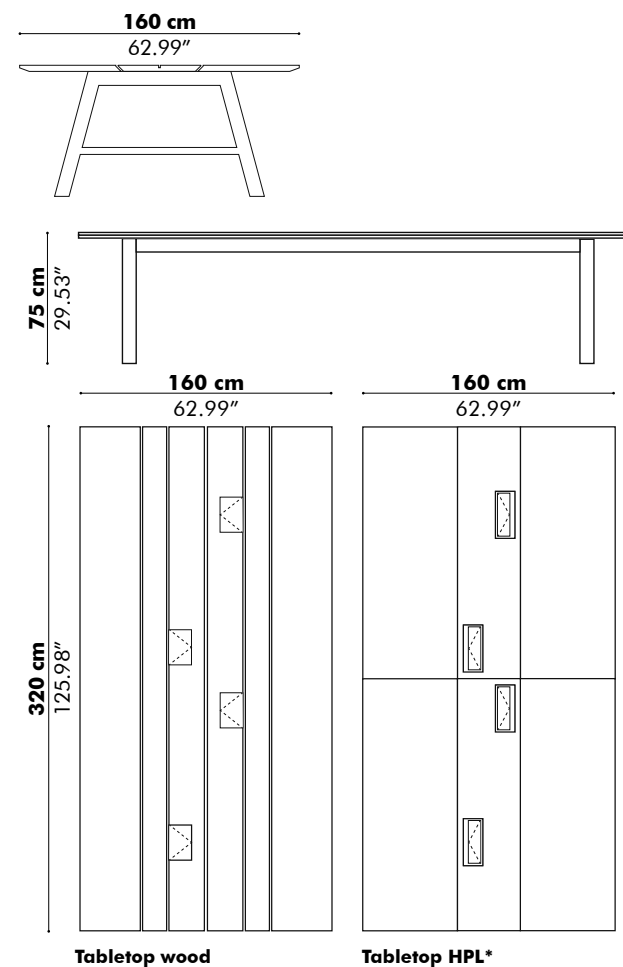

* HPL worktop always without grooves

Bench Wood

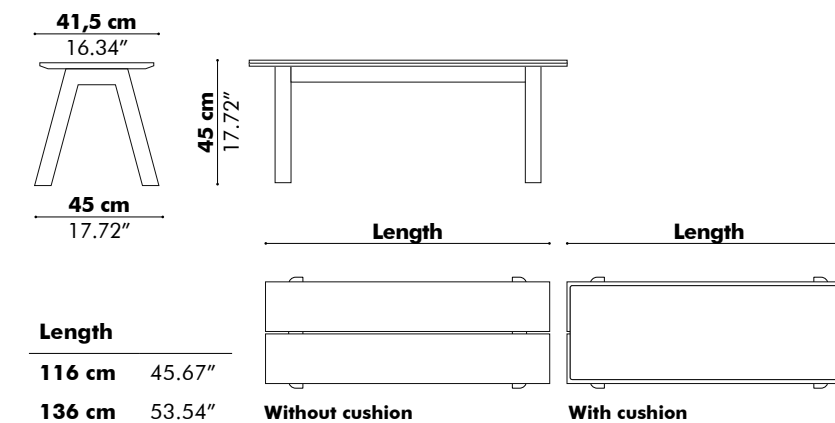

Connect Panel

Connect Panel in Wood or Felt can be mounted to the BuzziPicNic Desk High. Connection brackets and screws are included.

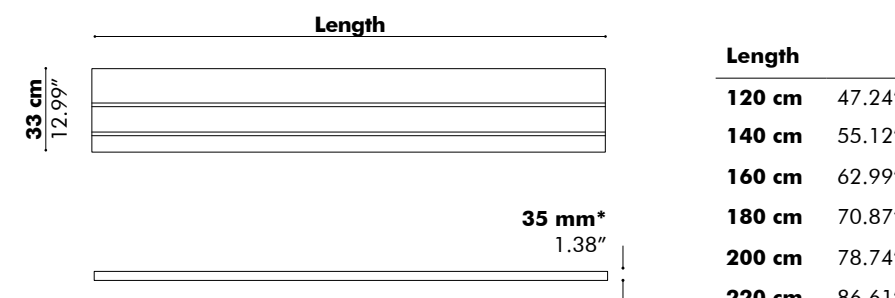

*Thickness of connect panel 35 mm | 1.38" Wood or 12 mm | 0.47" Felt

Finishes

Base always in wood
 Tabletop in wood (same finish as base) or HPL

Wood



HPL



Bench Cushion in fabric collections CAT A, B, C, D, E, F
 (check our application overview p. 330)

Options

Electrification

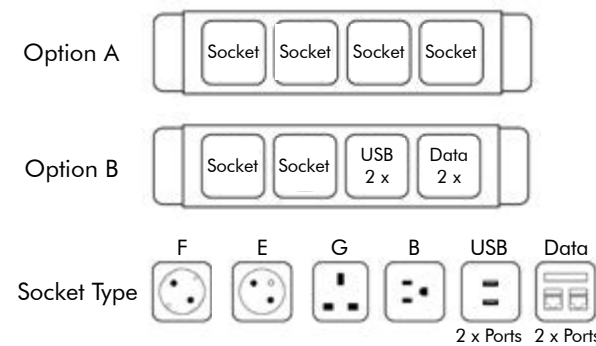

Cable entry cover HPL

Powder coated aluminum in black (RAL 9005), white (RAL 9010) or alu color (RAL 9006)

How to order

Model
 Size (W x L)
 Wood finish base
 Wood finish tabletop (same as base) or color HPL
 Electrification



BuzziPicNic Round

— by Alain Gilles

The first indoor picnic table in a round shape

Designer Alain Gilles has extended the BuzziPicNic family with a new round shape: the PicNic Round. With this design, everyone works on the same side of the table.



Models

Small

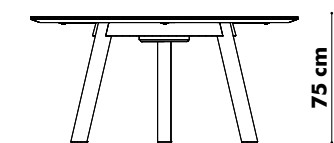

Ø 160 cm
62.99"

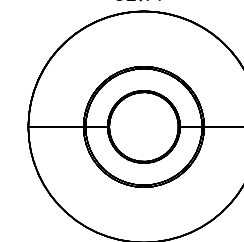

Large

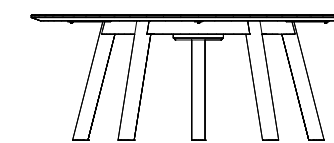

Ø 200 cm
78.74"

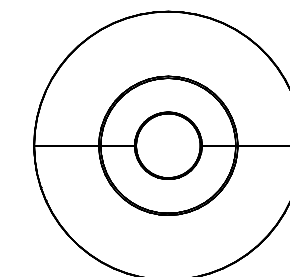

Finishes

Worktop & base in wood



Options

Electrification

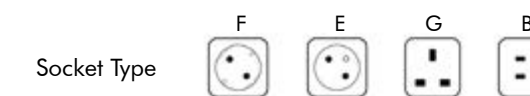
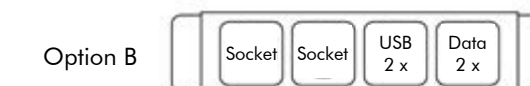
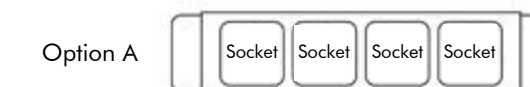

Cable entry cover
Solid or hinged

How to order

Size
Wood finish
Cable entry cover
Electrification



BuzziPlank

— by Gerd Couckhuyt

A multipurpose shelf with harmonious curves

BuzziPlank is a sleek and simple shelf with organic curves. It acts as a standing workspace or a place to hold your valuables and is fixed to the wall. Its plank-like design is softened with smooth edges. Available in solid wood.

Models

M

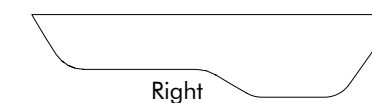
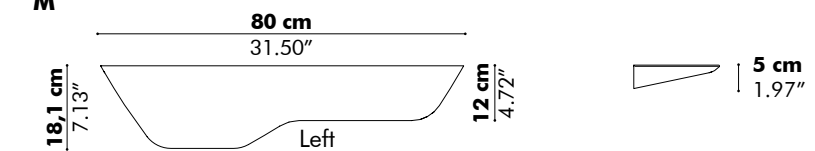

L

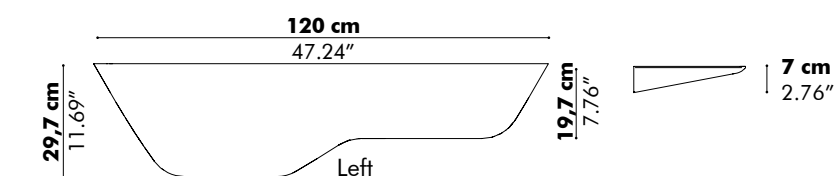

Mounting

Wall mounted

Finishes

Solid wood



How to order

Model
Size
Wood finish



BuzziSuzzi

— by Alain Gilles

Ready to go for a spin?

A joy that is shared is a joy made double! That's how the saying goes, and with BuzziSuzzi, designed by BuzziSpace Studio, you can make it come true. This rotating tray with a firm wooden surface makes it easier than ever to share food and office supplies with your colleagues, friends and family. BuzziSuzzi is available in all BuzziPicNic finishes to form a perfect match with the PicNic family.

Dimensions

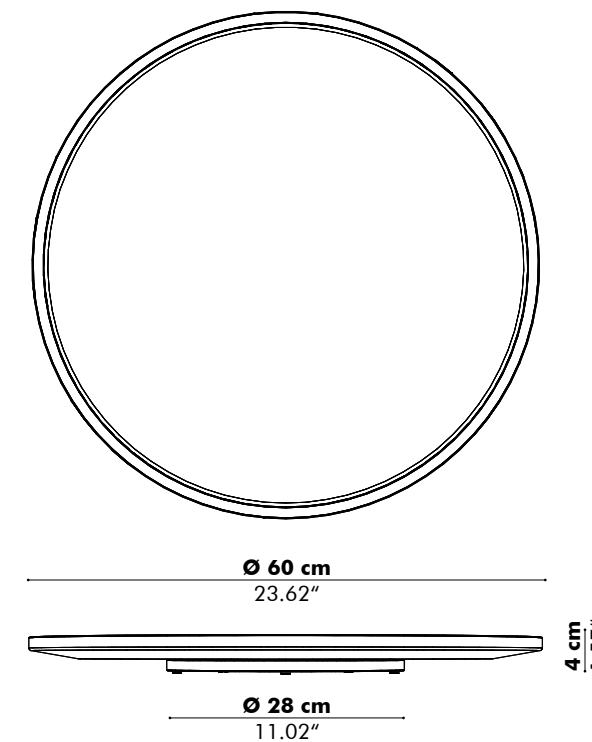

Finishes

Solid wood



How to order

Wood finish

BuzziTable

— by Alain Gilles

An effortless signature

Subtle, yet resilient. The straightforward character of BuzziTable is its force. With an oval-shaped table top and supporting structure refined to the essentials, this design leaves behind an effortless signature. The sideless silhouette brings everyone together, leaving no-one out of the conversation. Compared to other communal furniture and worktops, BuzziTable has a lightweight appearance, giving the illusion of a floating tabletop with the rounded corners vanishing below the surface. Available in a variety of materials and colors to easily accommodate a range of different styles and spaces—from communal to hospitality spaces and meeting areas. No matter the space, BuzziSpace makes a statement without being flamboyant. It is proof that less is more.



Models

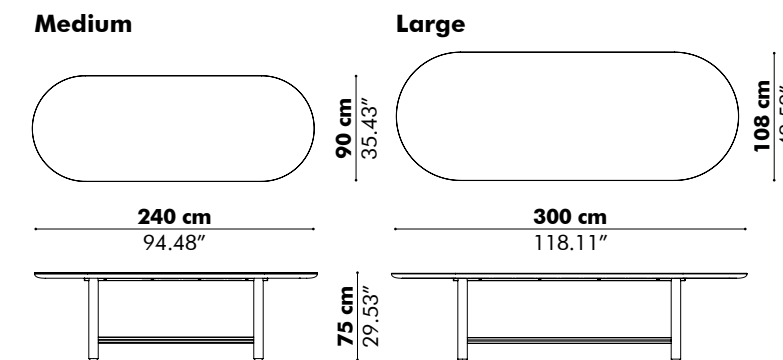

Finishes

Worktop ceramic



Worktop linoleum

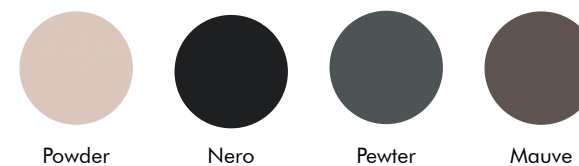

Finish base



Options

Electrification Unit

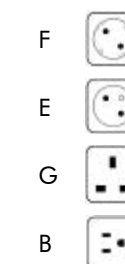

How to order

- Size
- Finish base
- Finish worktop
- Option



LIGHTING

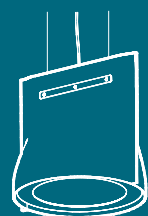

BuzziBell — 274



BuzziChandelier — 276

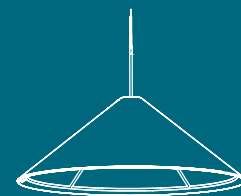

BuzziCone — 278

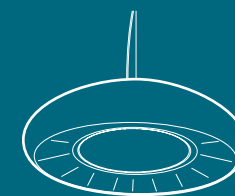

BuzziDome — 280



BuzziHat — 284

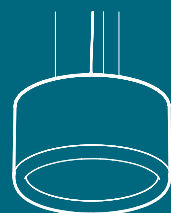

BuzziJet — 289

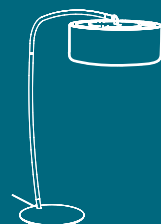

BuzziJet Standing — 292



BuzziLight Mono — 294

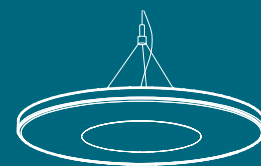

BuzziMoon — 297

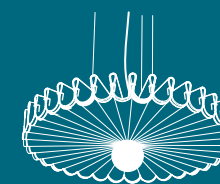

BuzziPleat Light — 300



BuzziProp — 304

LIGHTING

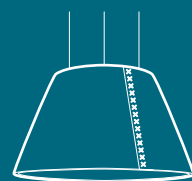

BuzziShade — 306

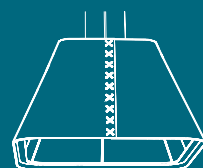

BuzziShade Square — 310



BuzziShade Standing — 312



BuzziSol — 314



BuzziTrom — 316

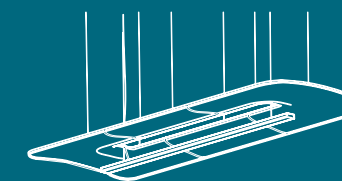

BuzziZepp Light — 318

BuzziBell

— by Chris Hardy

Acoustical lighting solution

Stretching the BuzziFelt to its limits, BuzziBell is recognized by the harmonious curve of its bell-shape. Its design adds softness to a room with the textural look of felt and a delicate, diffused light source or high performance LED engine. BuzziBell is offered in 12 BuzziFelt colors, has a metal feature and is CE and UL listed. BuzziBell makes a statement in offices, restaurants, hotels, institutions and residences.

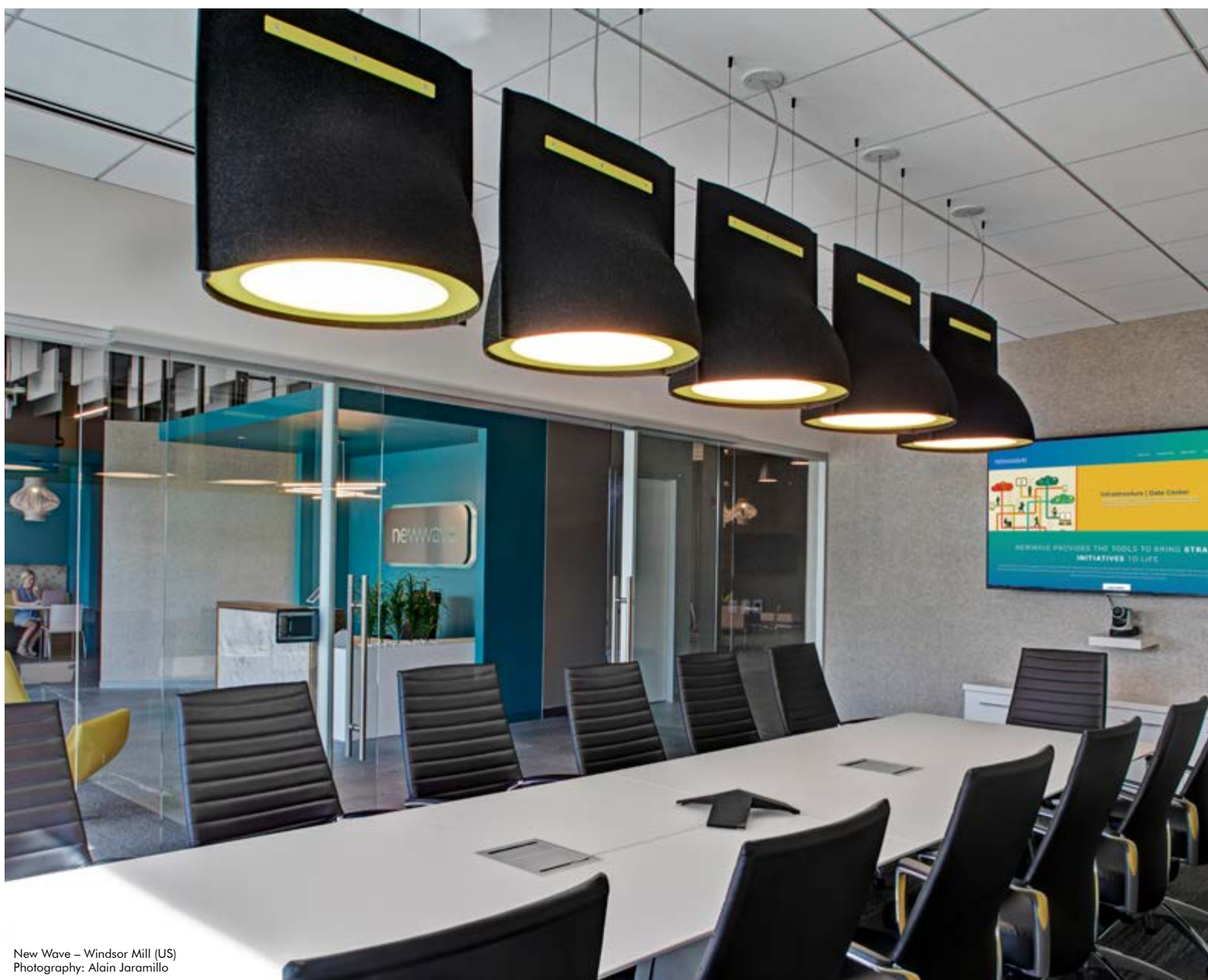

New Wave – Windsor Mill (US)
Photography: Alain Jaramillo

Dimensions

Front

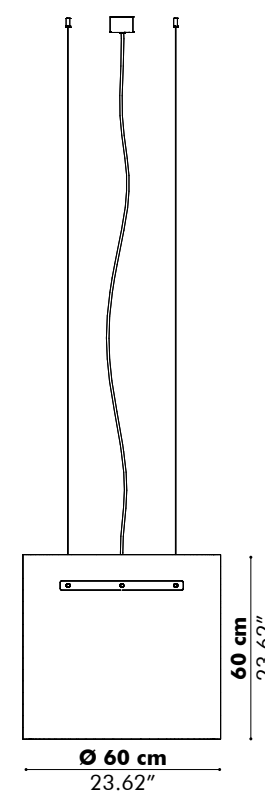

Side

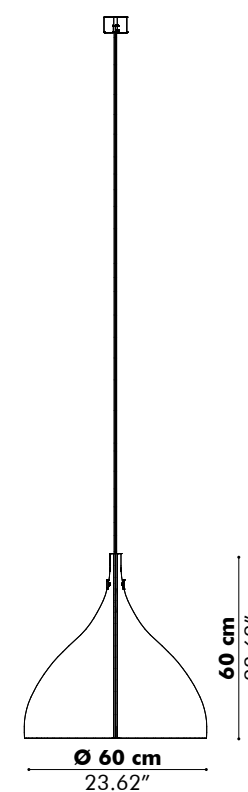

LUX levels

To enlighten your space with optimal LUX levels take following measures into account.

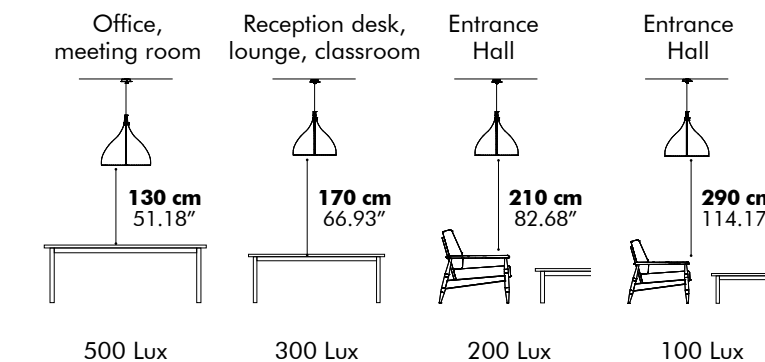

According to EN12464 (only on LUX levels) at full output

Acoustics

Acoustic Principles

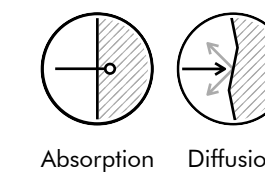

Absorption Diffusion

Acoustic Performance



Mid Tones High Tones

Finishes

Metal frame in black (RAL 9005), white (RAL 9010) or fluo yellow (RAL 1016)
Cover in BuzziFelt

Mounting

White metal ceiling canopy and transparant power cable incl.

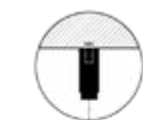

Ceiling Suspended.
Fixing System Screw with 2 cables of 2 m - 78.74"
or 4 m - 157.85" (black or alu)

Light

Input Voltage: 110 - 240V
Input Frequency: 50/60Hz
Lumen output: 2545 Lm
Color temperature: 3000K / 4000K on request
Color Rendering Index: 90
Dimming: 1-10V or Dali (CE/CB)
Diffuser: milky (URG22) or prismatic (UGR19) on request
CE/CB certified / cULus listed

How to order

BuzziFelt color
Color frame
Mounting option

BuzziChandelier

— by Sas Adriaenssens

An eye-catching lighting solution

Make a statement with your lighting by opting for the BuzziChandelier. A contemporary take on the classic chandelier. The perfect way to add atmosphere to your room with artful shadows and softened sounds. BuzziChandelier is an ideal design statement and acoustical solution for offices, restaurants, hotels, institutions, residences and more.



Dimensions

Chandelier

Chandelier Plain

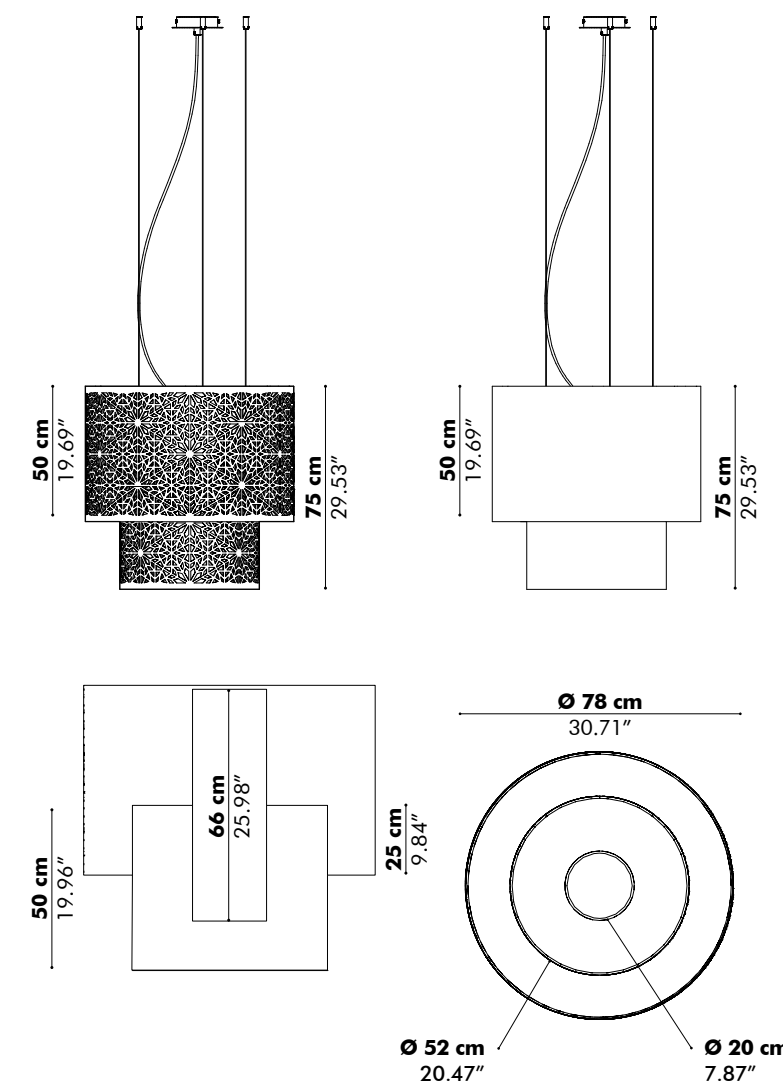

Finishes

Metal frame in black (RAL 9005)
Shades in BuzziFelt or BuzziFelt printed (Gold, Carrara, Emperor)

Mounting

Black metal ceiling canopy and black fabric power cable incl.



Ceiling Suspended
Fixing System Screw with 3 cables of 2 m - 78.74" or 5 m - 196.85" (black or alu)

Light

Input Voltage: 110 - 240V
4 pin CFL Bulb with 2G11 base included 55W (EU-CE certified)
Bulb excluded (US-cULus listed)

Acoustics

Acoustic Principles

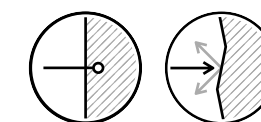

Absorption Diffusion

Acoustic Performance

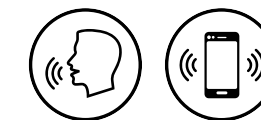

Mid Tones High Tones

How to order

Model
BuzziFelt finish
Mounting option

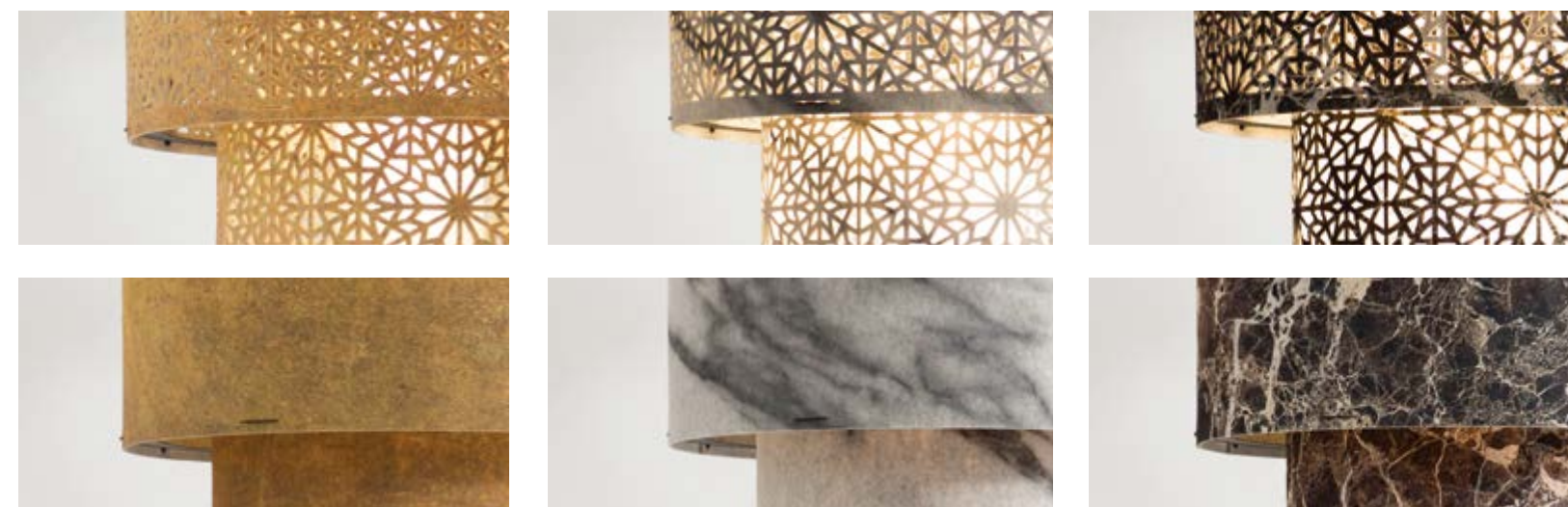

BuzziCone

— by BuzziSpace Studio

An iconic lighting solution

This cone-shaped pendant light manages to find the perfect balance between being a decorative element and a powerful acoustic performer. Select a globe LED for mood lighting or a spot LED, which offers direct functional light for any workstation. BuzziCone's versatility works well independently, or as a cluster to add depth and variation to any given space.



Models

133

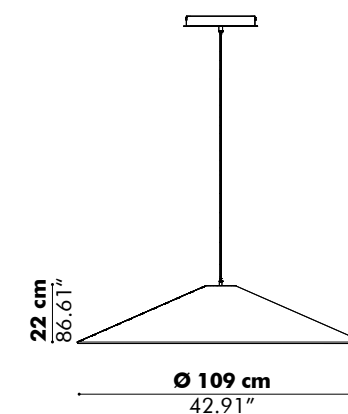

102

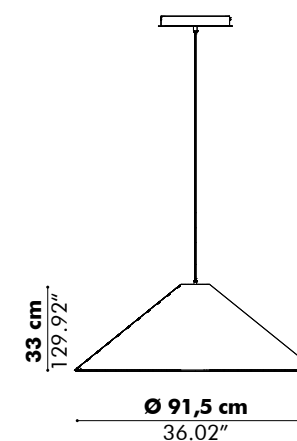

47

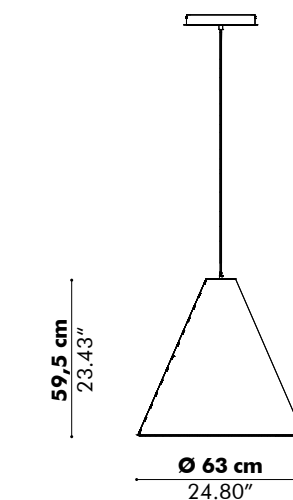

Light

Diffuser: Glass Globe or Reflector Spot
 Input Voltage: 110 – 240V
 Input Frequency: 50/60Hz
 Lumen Output: 1500 Lm
 Color Temperature: 3000K
 Color Rendering Index: 90
 Dimming: 1 - 10V or Dali (CE/CB)
 CE/CB certified / cULus listed

LUX levels

LED Spot

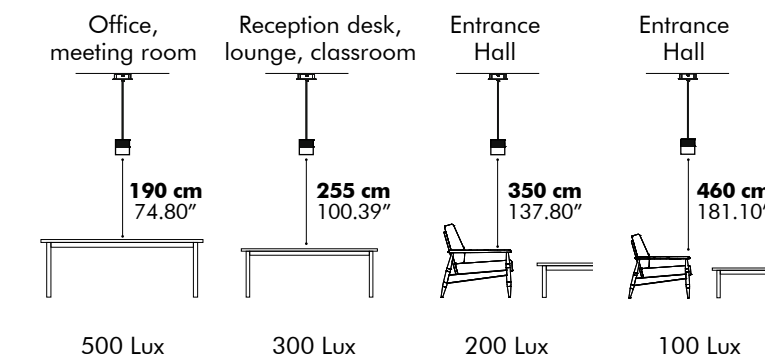

According to EN12464 (only on LUX levels) at full output

LED Globe

Only for decorative lighting effect.

Acoustics

Acoustic Principles

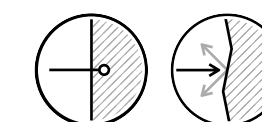

Absorption Diffusion

Acoustic Performance

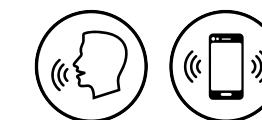

Mid Tones High Tones

Finishes

Metal frame in black (RAL 9005)
 Shade in one layer of BuzziFelt finished with push buttons in glossy black
 Extra layer in fabric collection CAT A, C possible (inside or outside)
 (Check our application overview p. 330)

Mounting

Black metal ceiling canopy and black fabric power cable.



Ceiling Suspended
 Fixing System Screw with 1 cable of 2 m or
 5 m - 196.85" (Black)

How to order

Model / Size
 BuzziFelt Color
 Option with extra layer fabric
 Mounting option
 Light option (Glass Globe or Reflector Spot)

BuzziDome

— by BuzziSpace Studio

Temple of silence

BuzziDome is a modern acoustic light distinct for its refined dome shape. BuzziDome's concave design, coupled with its acoustic foam element, acts as an excellent diffuser and absorber of sound. Therefore, BuzziDome provides exceptional acoustic treatment for open-plan settings. A recessed LED light source, paired with its tailored design, accentuates the pendant's meticulous craftsmanship while also emitting a warm, functional light. BuzziDome accommodates the demand for both sound absorption and light, being the perfect fit for open-plan workplaces, hospitality settings, and break-out areas. Pick yours from a wide range of colorful upholstery options. It will definitely complement the aesthetic scheme of your interior.



Dimensions

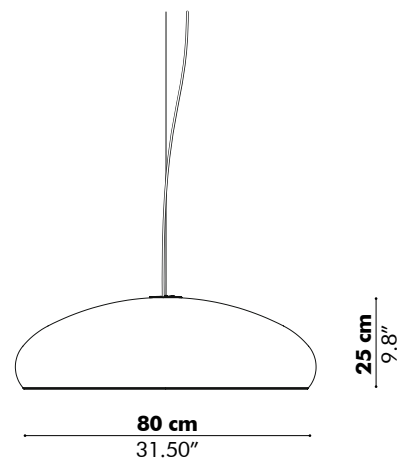

Finishes

Acoustic foam upholstered element with integrated LED disk.
Fabric collections CAT A, B, C, D and E
(Check our application overview p. 330)

Mounting

White metal ceiling canopy and transparent power cable incl.

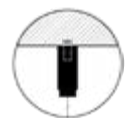

Ceiling Suspended Straight
Fixing System Screw with 1 cable of 2 m - 78.74" or 4 m - 196.85" (black or alu)



Light

Input Voltage: 110 - 240V
Input Frequency: 50/60Hz
Lumen Output: 2545 Lm
Color Temperature: 3000K / 4000K on request
Color Rendering Index: 90
Dimming: 1-10V or Dali
Diffuser: milky (UGR22) or prismatic (UGR19) on request
CE/CB certified / cULus listed

LUX levels

To enlight your workplace or room with optimal LUX levels take following measures into account.

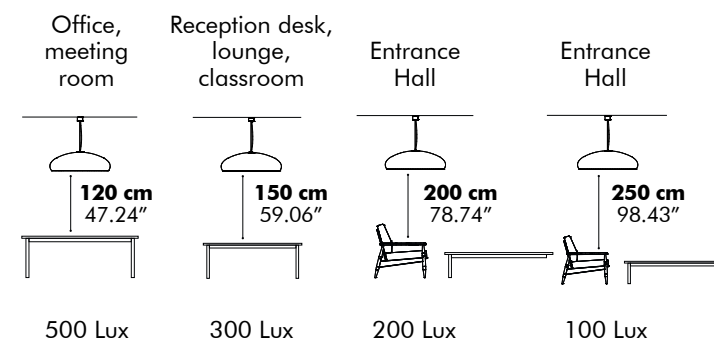

According to EN12464 (only on LUX levels) at full output

Acoustics

Acoustic Principles

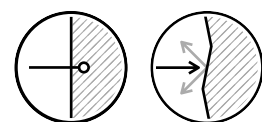

Absorption Diffusion

Acoustic Performance



Low Tones Mid Tones High tones

How to order

Fabric (CAT > collection > color)
Mounting option



BuzziHat

— by Alain Gilles

Say goodbye to noisy environments

A decorative and highly recognizable hat-shaped pendant light with excellent sound absorption capabilities. Its unique design, combining an upholstered part with a metal shade is bound to steal the attention in any space. The upholstered foam body is available in a wide palette of color and fabric combinations, while the metal shade and ring come in 4 finishes (black, white, beige red and gold). Mix colors of your choosing and match the fabric of BuzziHat with the color of your furniture to create an impeccable setting. BuzziHat is available in different sizes to fit different noisy environments which makes it the ultimate acoustic lighting for any office, lobby or restaurant that needs acoustic absorption treatment combined with high-quality lighting.



Models

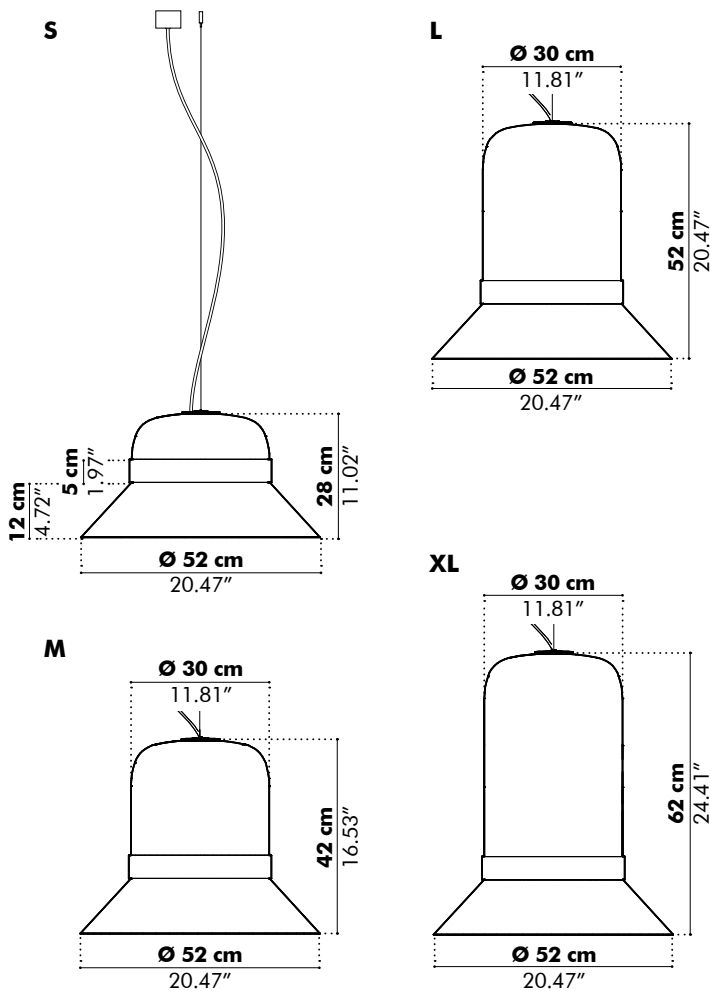

Finishes

Metal Shade and decorative ring in black (RAL 9005), white (RAL 9010), beige red (RAL 3012) or gold
 Upholstery in fabric collections CAT A, B, C, D, E
 (Check our application overview p. 330)

Mounting

White metal ceiling canopy and transparent power cable incl.



Ceiling Suspended.
 Fixing System Screw with 1 cable of 2 m - 78.74"
 or 4 m - 157.48" (black or alu)

Light

Input Voltage: 110 - 240V
 Input Frequency: 50/60Hz
 Lumen Output: 2000 Lm
 Color Temperature: 3000K
 Color Rendering Index: 80
 Dimming: 1-10V
 Diffuser: milky (UGR20) or prismatic (UGR19) on request
 CE/CB certified / cULus listed

LUX levels

To enlight your workplace or room with optimal LUX levels take following measures into account.

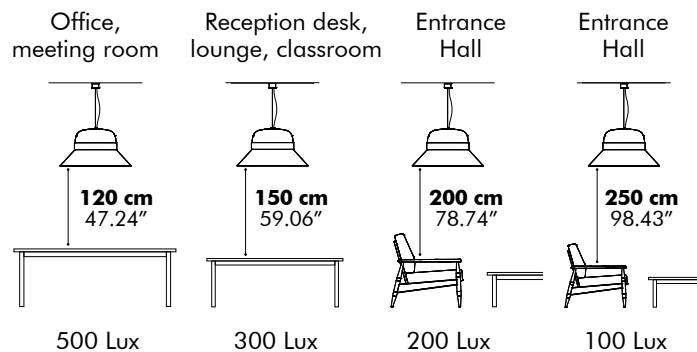

According to EN12464 (only on LUX levels) at full output

Acoustics

Acoustic Principles

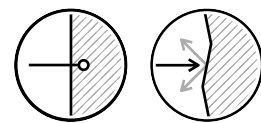

Absorption Diffusion

Acoustic Performance

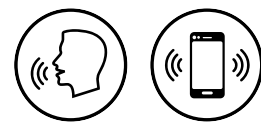

Mid Tones High Tones

How to order

Model
 Fabric (CAT > collection > color)
 Color metal shade
 Color decorative ring
 Mounting option





BuzziJet

— by BuzziSpace Studio

Powerful acoustic circle of light

Form follows function with BuzziJet, an intentionally simple design based on the principles of geometric acoustics. Available in three different diameters, this cylindrical design allows sound waves to bounce back-and-forth within the radius of its circular body, and in turn, mitigates noise. Despite its size, BuzziJet is lightweight and airy due to its upholstered foam core. Its soft presence evokes a majestic sense of serenity, while concealed inside its body, a powerful light source emits warm, pleasant light.

Dimensions

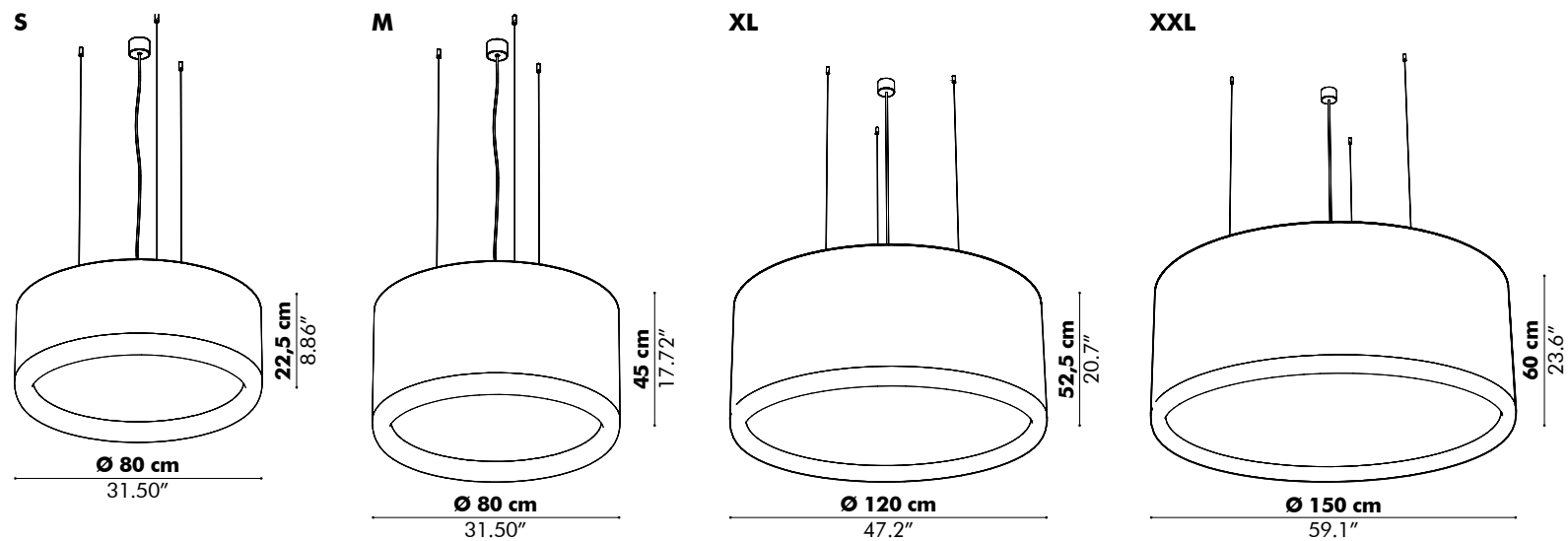

Finishes

Metal frame in white (RAL 9010)
 Upholstery in fabric collections CAT A, B, C, D and E
 (Check our application overview p. 330)

Mounting

White metal ceiling canopy and transparent power cable incl.

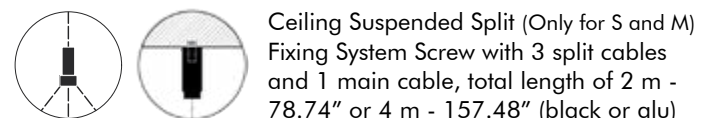
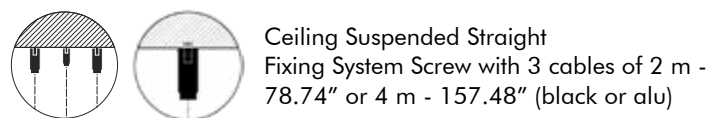

Light

S, M and XL

Input Voltage: 230V / 120V
 Input Frequency: 50/60Hz
 Lumen Output: 2545 Lm
 Color temperature: 3000K / 4000K on request
 Color Rendering Index: 90
 Dimming: 1-10V or Dali (CE/CB)
 Diffuser: milky (UGR22) or prismatic (UGR19) on request
 CE/CB certified / cULus listed

XXL

Input Voltage: 230V / 120V
 Input Frequency: 50/60Hz
 Lumen Output: 6232 Lm
 Color temperature: 3000K
 Color Rendering Index: 90
 Dimming: 1-10V
 Diffuser: milky (UGR23)
 CE/CB certified / cULus listed From March 2021

LUX levels

To enlight your workplace or room with optimal LUX levels take following measures into account.

S, M and XL

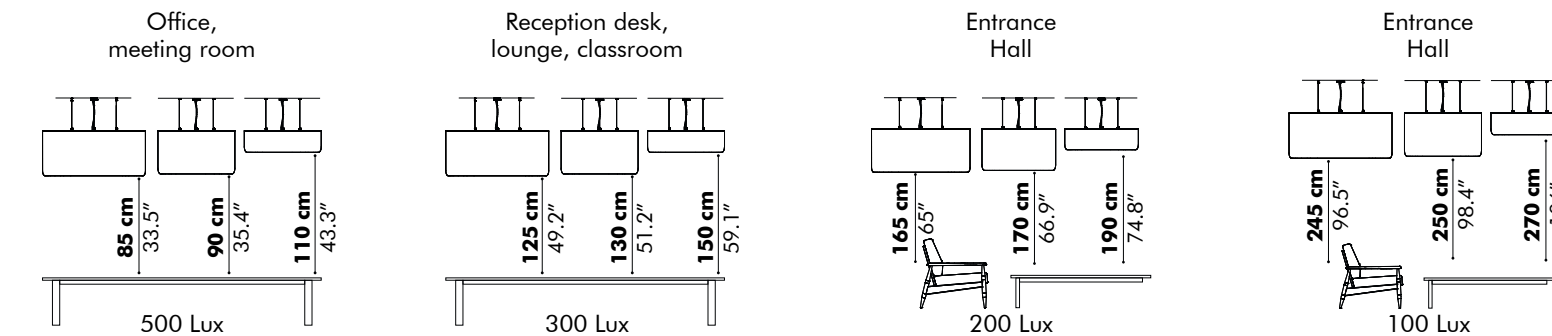

XXL

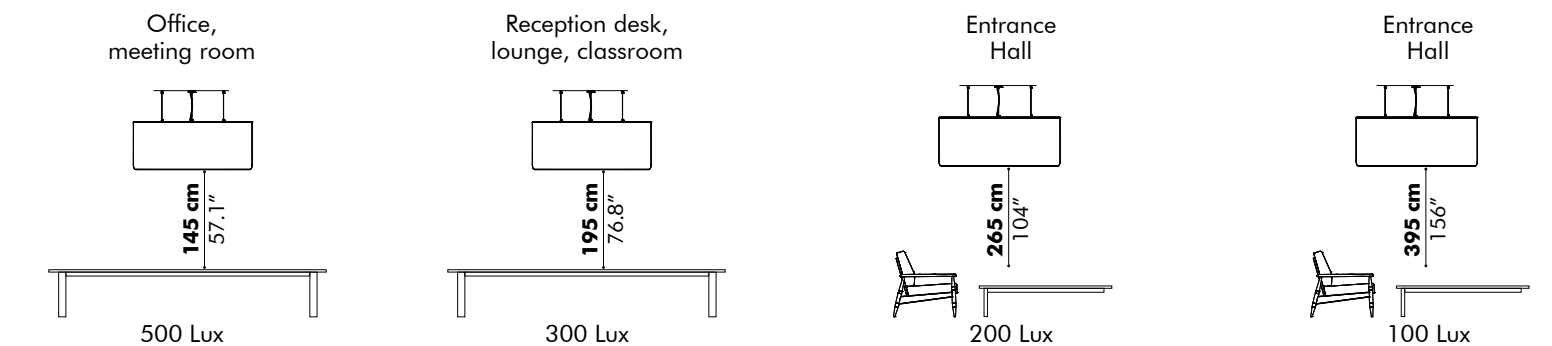

According to EN12464 (only on LUX levels) at full output

Acoustics

Acoustic Principles

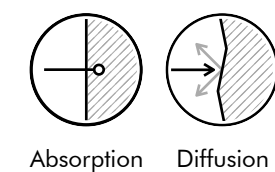

Acoustic Performance



How to order

Fabric (CAT > collection > color)
 Mounting option
 Size



BuzziJet Standing

— by BuzziSpace Studio

An elegant lighting solution

BuzziJet Standing is a functional acoustical lighting solution designed to suit flexible and open spaces. As a solution that requires no installation, this elegant lighting option is also a perfect add-on to any lounge area or break-out zone and can dim to create different atmospheres.

Models

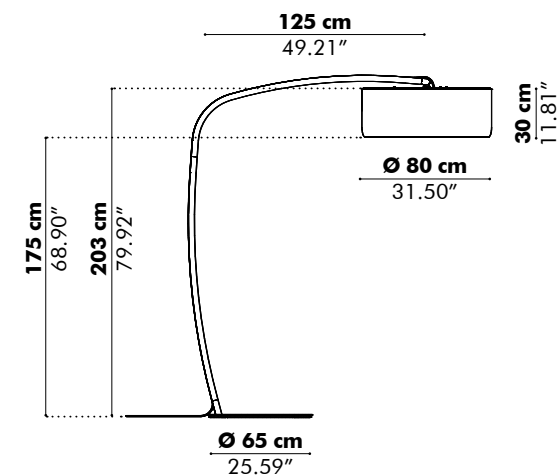

Finishes

Aluminum arch in black (RAL 9005)
 Metal baseplate in black (RAL 9005)
 Upholstered acoustic shade in fabric collection CAT A, B, C, D and E
 Fabric power cable in Black or Red
 (Check our application overview p. 330)

Light

Wattage: 21W
 Input Voltage: 120V - 240V
 Input Frequency: 50/60Hz
 Lumen Output: 1900 lumen
 Color Temperature: 3000K
 Color Rendering Index: >95
 Dimming: Floordimmer
 Unified Glare Rating: 22
 CE/CB certified / cULus listed

Lux levels

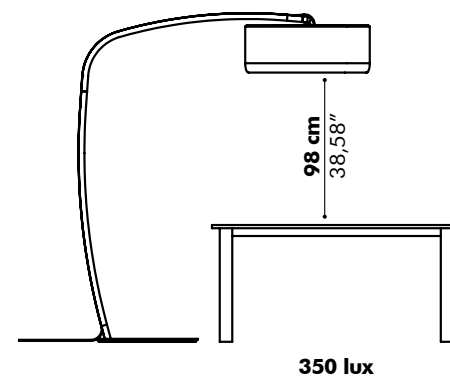

Acoustics

Acoustic Principles

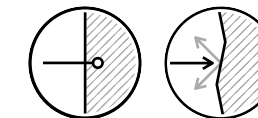

Absorption Diffusion

Acoustic Performance



Low Tones Mid Tones High Tones

How to order

Color fabric power cable
 Fabric (CAT, collection, color)

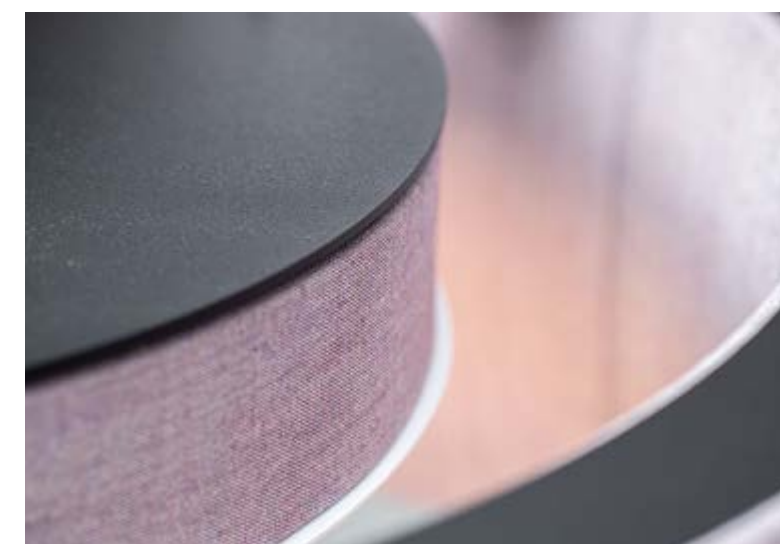

BuzziLight Mono

— by Sas Adriaenssens

Lighting fixture in BuzziFelt

BuzziLight Mono is a striking phenomenon. The strips of sound-absorbing felt are fixed around a steel structure, allowing this light object to take on different shapes. BuzziLight Mono makes a design statement with just one color of BuzziFelt.



Splunk, McLean (US)
Photography: Chris Spielmann

Models

L

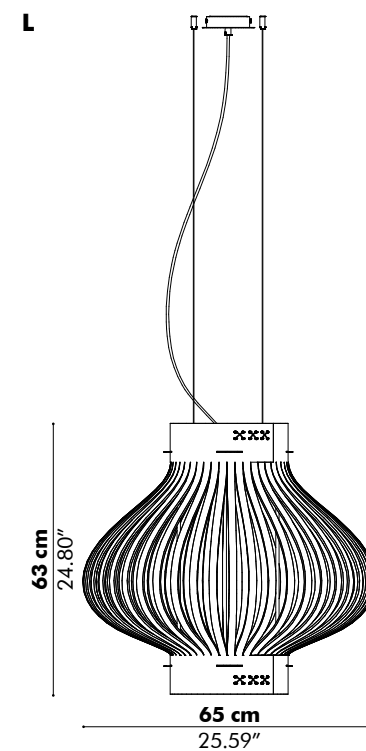

Finishes

Metal frame always in black (RAL 9005)
One layer of BuzziFelt
Black or white lace
Black or white stitch or no stitch

Mounting

Black metal ceiling canopy and black fabric power cable incl.

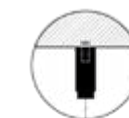

Ceiling Suspended
Fixing System Screw with 2 cables of 2 m - 78.74" or
5 m - 196.85" (black or alu)

Light

Excl. lightbulb
E27, max 60W (EU-CE/CB certified)
E26, max 100W (US-cULus listed)

Options

LED bulb E27, 5W (EU)

Acoustics

Acoustic Principles

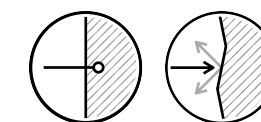

Absorption Diffusion

Acoustic Performance

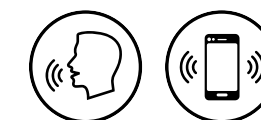

Mid Tones High Tones

How to order

BuzziFelt color
Color lace
Stitch
Mounting option



BuzziMoon

— by BuzziSpace Studio

Embedded light

BuzziMoon offers the best of both worlds, a highly functional general lighting embedded in a proven acoustic ceiling solution. One of the first acoustical lighting solutions that are equally performant on lighting as well as on an acoustic level. The LED light module is designed specifically to answer the request for general lighting in office spaces. BuzziMoon can be finished off in different fabrics and various 3D patterns. The diffuser gives it a “full moon” lighting experience.

Dimensions

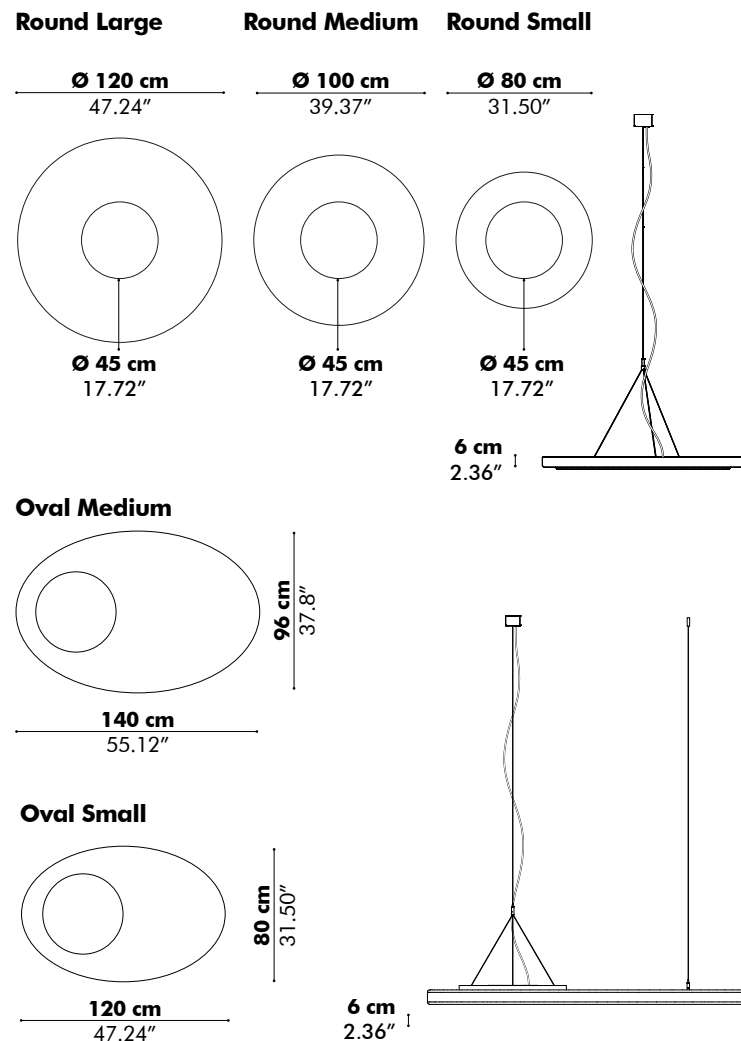

Patterns

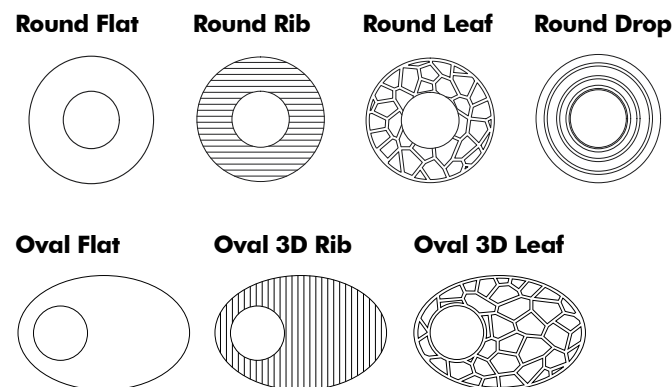

Mounting

White metal ceiling canopy and transparent power cable.

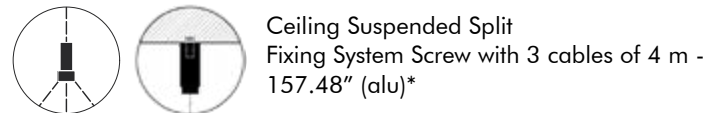

* Moon Oval with additional cable & Fixing System Screw.

Finishes

Upholstery in fabric collections CAT A, B, C, D, E
(Check our application overview p. 330)

Light

Input Voltage: 110 - 240V
Input Frequency: 50/60Hz
Lumen Output: 2545 Lm
Color temperature: 3000K / 4000K on request
Color Rendering Index: 90
Dimming: 1-10V or Dali (CE/CB)
Diffuser: milky (UGR22) or prismatic (UGR19) on request
CE/CB certified / cULus listed

LUX levels

To enlighten your space with optimal LUX levels take following measures into account.

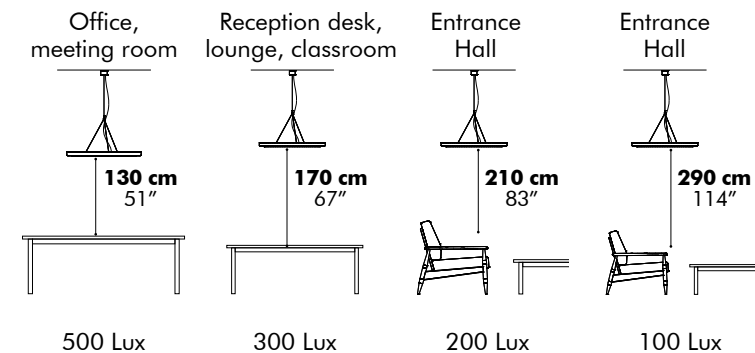

According to EN12464 (only on LUX levels) at full output

Acoustics

Acoustic Principles

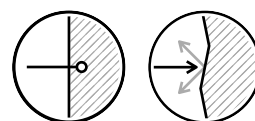

Absorption Diffusion

Acoustic Performance

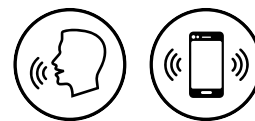

Mid Tones High Tones

How to order

Size
Pattern
Fabric (CAT > collection > color)
Mounting option

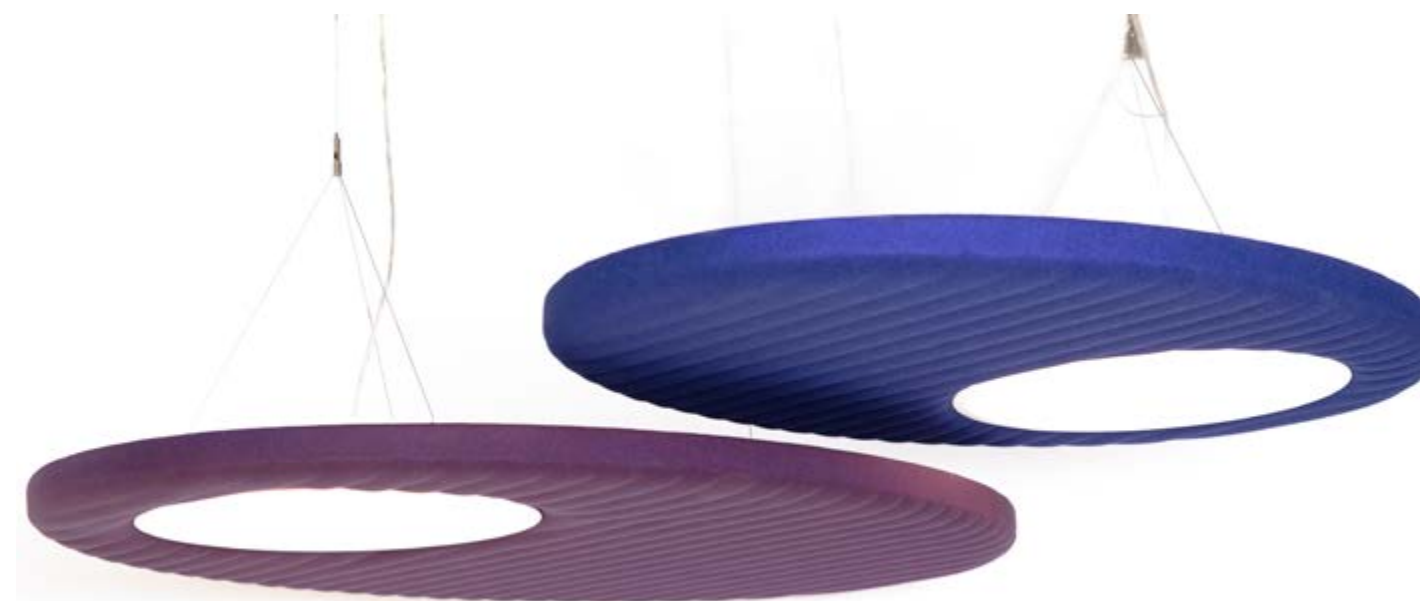

BuzziPleat Light

— by 13&9 Design and BuzziSpace Studio

A series of architectural solutions

BuzziPleat delivers sound control with an architectural edge. This series reinterprets ancient techniques used in fashion design, like smocking and pleating, to create large-scale, yet lightweight sculptural forms, made of sound-absorbing BuzziFelt. Architectural folds maximize surface area, delivering exceptional acoustic performance. Combine the hanging acoustic pendants with a light source to marry sound control and illumination in one multi-purpose product, BuzziPleat Light.



Dimensions

Ripple M

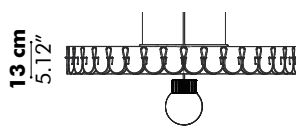

Ø 100 cm
39.37"

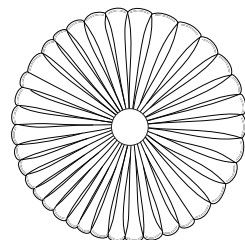

Ripple L

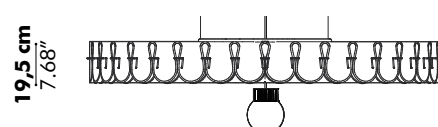

Ø 150 cm
59.06"

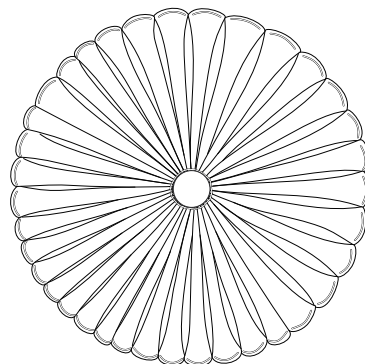

Edel M

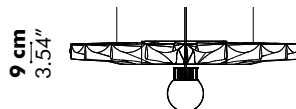

Ø 100 cm
39.37"

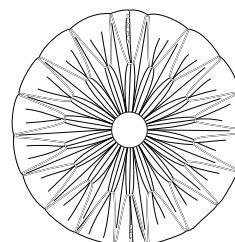

Edel L

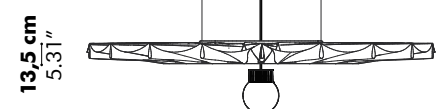

Ø 150 cm
59.06"

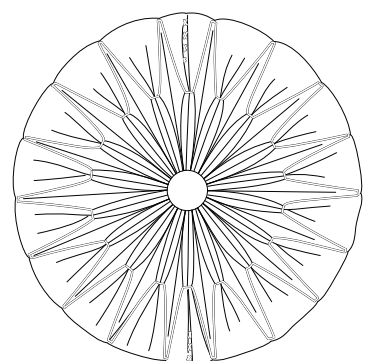

Finishes

Pleat in BuzziFelt: OffWhite, StoneGrey, Lime, Anthracite
Lace in OffWhite or Black
LED Light source with powder-coated metal heatsink in black (RAL 9005)
(Check our application overview p. 330)

Mounting

Black metal ceiling canopy and black fabric power cable incl.



Ceiling Suspended.
Fixing System Screw with 3 cables of 2 m - 78.74" or 5 m - 196.85" (black or alu)

Light

Diffuser: glass globe or reflector spot
Input voltage: 110-240V
Input freq: 50/60 Hz
Lumen Output: 1500 Lm
Color Temperature: 3000K
Color Rendering Index: 90
Dimming: 1-10V or Dali on request
LED Light source CE/CB certified / cULus listed

LUX levels

To enlighten your space with optimal LUX levels take following measures into account.

LED Spot

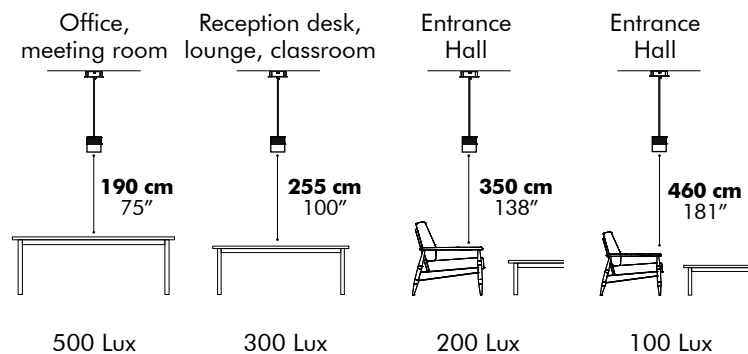

LED Globe

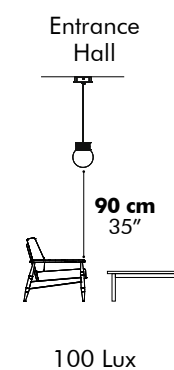

According to EN12464 (only on LUX levels) at full output

Acoustics

Acoustic Principles

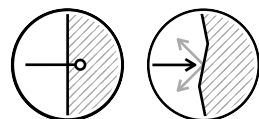

Absorption Diffusion

Acoustic Performance

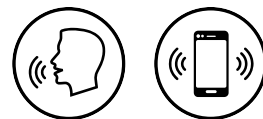

Mid Tones High Tones

How to order

Size
Model
Color lace
Mounting option



BuzziProp

— by BuzziSpace Studio

Aerodynamic noise regulating light

Reminiscent of the tubular shape of a propeller, BuzziProp is an aerodynamic design with sound-absorbent capabilities. With its minimal design, BuzziProp allows your mind to travel to an uninterrupted and balanced space for improved concentration, productivity, and focus at work.



Nvidia, Reading (UK)
Photography: Siobhan Doran

Dimensions

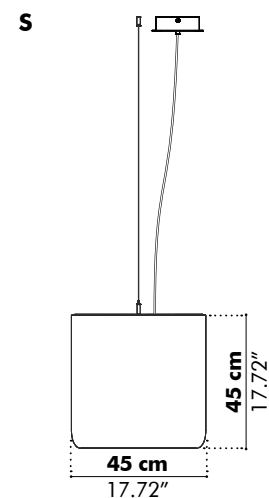

Finishes

Metal frame in black (RAL 9005)
Upholstery in fabric collections CAT A, B, C, D and E (Check our application overview p. 330)
LED Light source with powder-coated metal heatsink in black (RAL 9005)

Mounting

Black metal ceiling canopy and black fabric power cable incl.

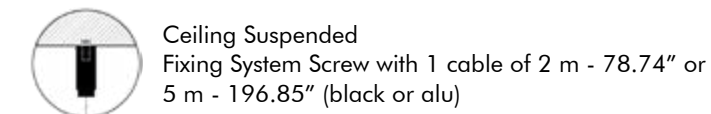

Light

Diffuser: glass globe or reflector spot
Input Voltage: 110 - 240V
Input Frequency: 50/60Hz
Lumen Output: 1500 Lm
Color Temperature: 3000K
Color Rendering Index: 90
Dimming: 1-10V or Dali on request
CE/CB certified / cULus listed

Acoustics

Acoustic Principles

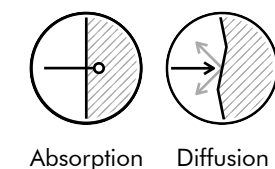

Acoustic Performance



How to order

Fabric (CAT > collection > color)
Mounting option

LUX levels

To enlighten your space with optimal LUX levels take following measures into account.

LED Spot

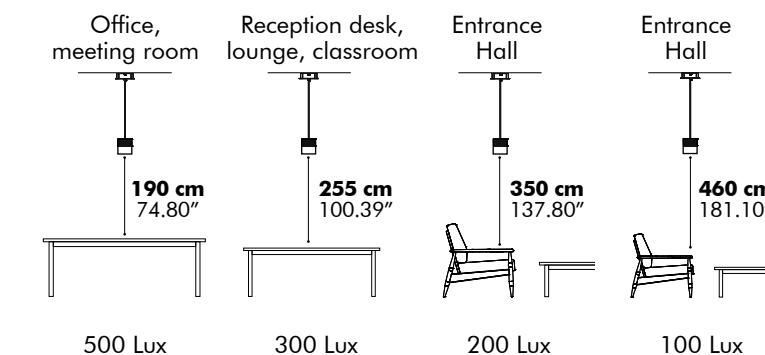

According to EN12464 (only on LUX levels) at full output

LED Globe

Only for decorative lightning effect.

BuzziShade

— by BuzziSpace Studio and Stal Collectief

A sound-absorbing lighting fixture in BuzziFelt

BuzziShade's design prevents eavesdroppers from hearing your private conversations and reduces external noise levels to a minimum. BuzziShade's versatility makes it a fantastic addition to any office, waiting room, or restaurant and is designed with large-scale settings in mind. Be creative by adding a layer of colorful fabric to BuzziFelt shades.

Models

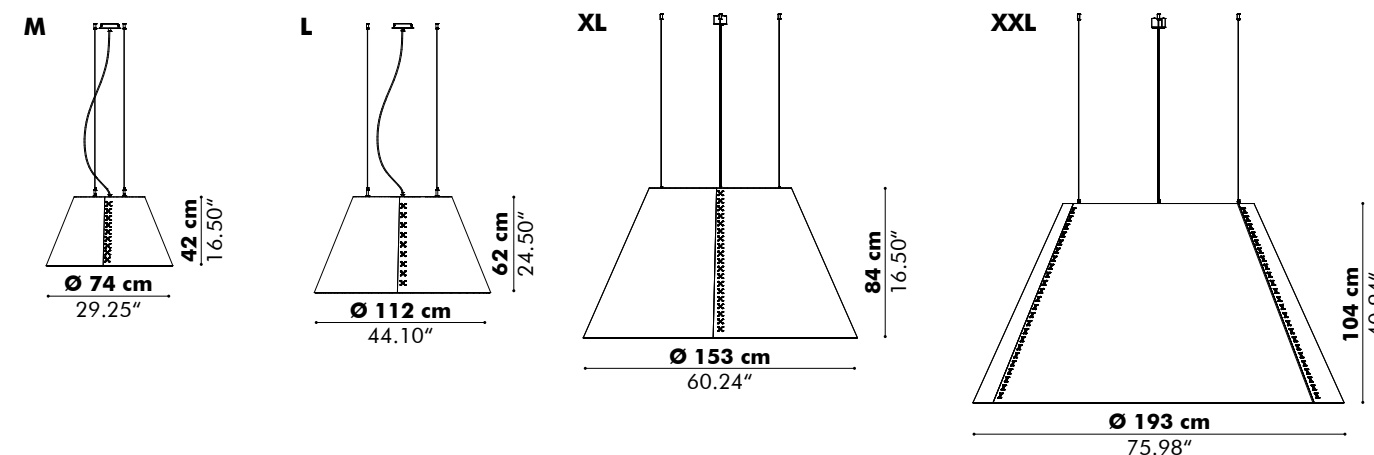

Light

Retrofit	LED Globe	LED Spot	LED Disk
Available for M, L	Available for M, L	Available for M, L	Available for XL, XXL
Excl. lightbulb E27, max 60W (EU) E26, max 100W (US)	Input Voltage: 110 - 240V Input Frequency: 50/60Hz Lumen Output: 1500 Lm Color Temperature: 3000K Color Rendering Index: 90 Diffuser: glass globe or reflector spot Dimming: 1-10V or Dali on request	Input Voltage: 110 - 240V Input Frequency: 50/60Hz Lumen Output: 1500 Lm Color Temperature: 3000K / 4000K on request Color Rendering Index: 90 Diffuser: milky (UGR22) or prismatic (UGR19) on request Dimming: 1-10V or Dali (CE/CB)	Input Voltage: 110 - 240V Input Frequency: 50/60Hz Lumen Output: 2545 Lm Color Temperature: 3000K / 4000K on request Color Rendering Index: 90 Diffuser: milky (UGR22) or prismatic (UGR19) on request Dimming: 1-10V or Dali (CE/CB)
Fabric power cable in black, red or orange (CE only)	Black metal ceiling canopy. Fabric power cable in black	Black metal ceiling canopy. Fabric power cable in black	White metal ceiling canopy. Transparent cable
Black or white metal ceiling canopy	CE/CB certified / cULus listed	CE/CB certified / cULus listed	CE/CB certified / cULus listed

LUX levels

To enlighten your space with optimal LUX levels take following measures into account.

Spot

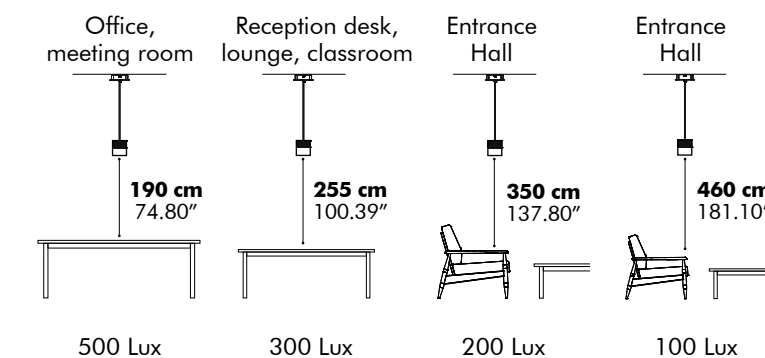

Globe

Only for decorative lighting effect.

According to EN12464 (only on LUX levels) at full output



Finishes

Shade in one layer of BuzziFelt
Extra layer in fabric collections CAT A, C possible inside or outside
(Check our application overview p. 330)

M/L: Frame in white (RAL 9010), black (RAL 9005),
fluo orange (RAL 2005) or uncoated aluminum
Color lace in black, white or fluorescent orange

XL/XXL: Frame in white (RAL 9010), black (RAL 9005),
or uncoated aluminum
Color lace in black or white

Mounting

M/L



Ceiling Suspended
Fixing System Screw with 2 cables of 2 m - 78.74" or
5 m - 196.85" (black or alu)

XL/XXL

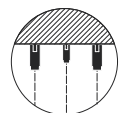

Ceiling Suspended Straight
Fixing System Screw with 3 cables of 2 m -
78.74" or 4 m - 157.48" (black or alu)

Acoustics

Acoustic Principles

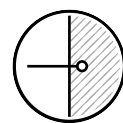

Absorption

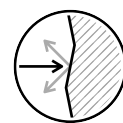

Diffusion



Mid Tones



High Tones

Acoustic Performance

How to order

- Size
- Color frame
- BuzziFelt color
- Option extra layer fabric (CAT > collection > color > inside or outside)
- Color lace
- Mounting option
- Light option
- Color power cable (retrofit)
- Color ceiling canopy (retrofit)

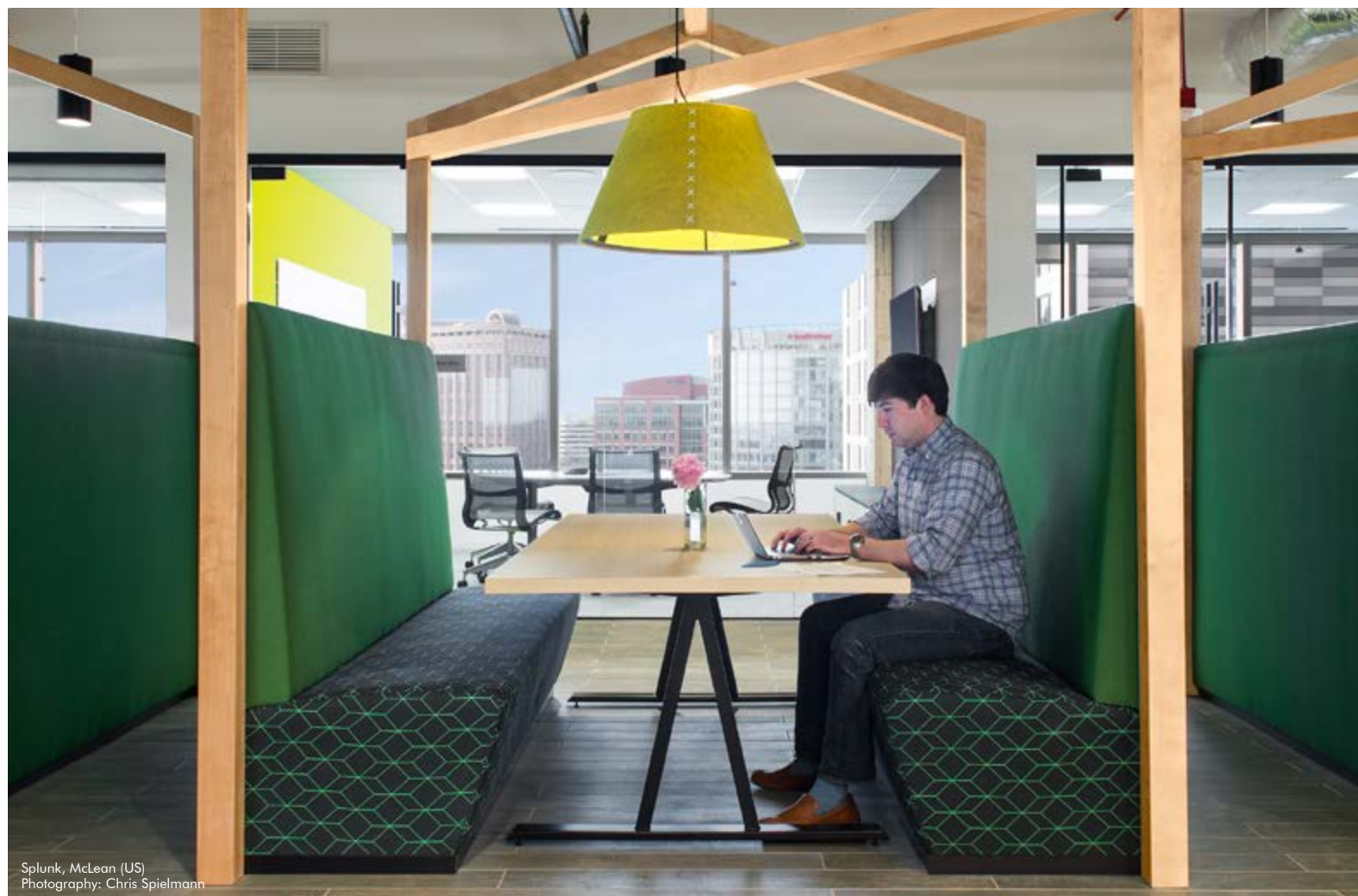

Splunk, McLean (US)
Photography: Chris Spielmann



360i - London (GB)
Photography: Grey Limited

BuzziShade Square

— by BuzziSpace Studio and Stal Collectief

Noise-reducing pendant lighting with a twist

Meet BuzziShade Square with its unique personality. It combines a nicely finished metal frame, upholstered in BuzziFelt, with our signature lacing available in a wide range of colors. This meticulously crafted lighting fixture, with acoustic capabilities, reduces external noise level to a maximum while blending in with the interior. It is such a versatile modern lighting that means the perfect addition to any office, lobby area or restaurant. Be adventurous and hang several square pendants in a row for an even more distinctive setting and well-balanced space.



Models

M

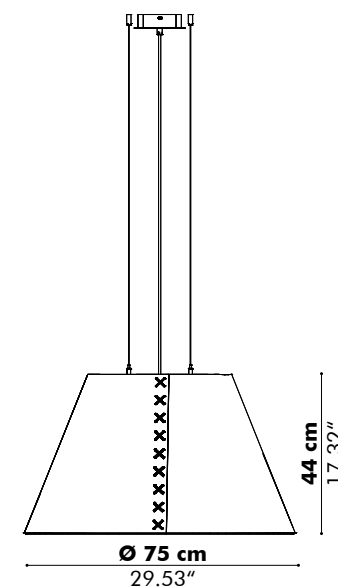

Finishes

Metal frame in black (RAL 9005), white (RAL 9010), uncoated aluminum or fluorescent orange (RAL 2005)
Shade in one layer of BuzziFelt
Color lace in black, white or fluorescent orange
(Check our application overview p. 330)

Acoustics

Acoustic Principles

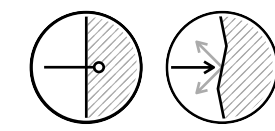

Absorption Diffusion

Acoustic Performance

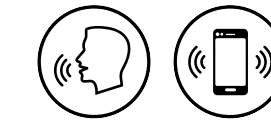

Mid Tones High Tones

Light

Retrofit

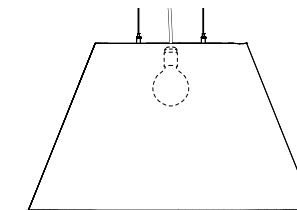

Excl. lightbulb
E27, max 60W
EU-CE/CB certified
E26, max 100W
cULus listed

Black or white metal ceiling canopy
Fabric power cable in black, red or fluorescent orange*
* only CE certified

LED Spot

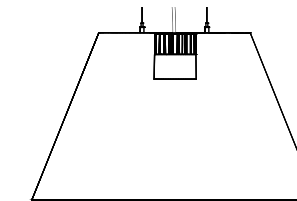

LED Globe

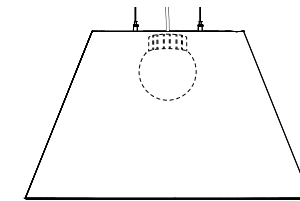

Input Voltage: 110 - 240V
Input Frequency: 50/60Hz
Lumen Output: 1500 Lm
Color Temperature: 3000K
Color Rendering Index: 90
Dimming: 1-10V or Dali on request

Black metal ceiling canopy
Fabric power cable in black

CE/CB certified / cULus listed

Mounting

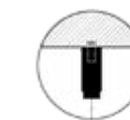

Ceiling Suspended
Fixing System Screw with 2 cables of 2 m - 78.74" or 5 m - 196.85" (black or alu)

LUX levels

To enlighten your space with optimal LUX levels take following measures into account.

Spot

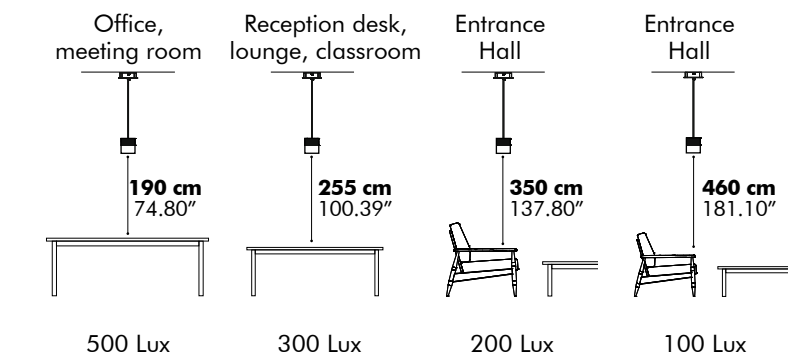

Globe

Only for decorative lighting effect

According to EN12464 (only on LUX levels) at full output

How to order

Color frame
BuzziFelt color
Color lace
Mounting option
Light option
Color power cable (Retrofit)
Color ceiling canopy (Retrofit)

BuzziShade Standing

— by BuzziSpace Studio and Stal Collectief

Floor lamp in BuzziFelt

BuzziShade Standing offers decorative lighting and reduces external noise levels to a minimum. BuzziShade is extremely versatile. This floor lamp is an ideal add-on to any waiting room, hotel lobby or even at home to create that perfect hideaway. BuzziShade is the culmination of an artistic collaboration between BuzziSpace and the four young Belgian furniture designers of Stal Collectief.



Kienbaum, Cologne (DE)
Photography: Philipp Jester

Models

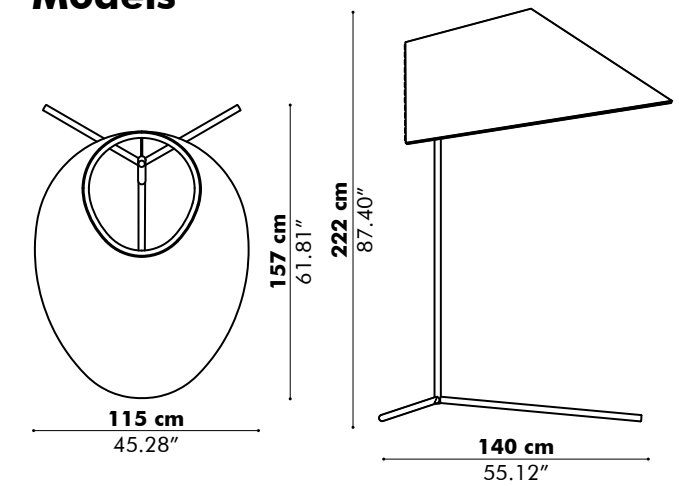

Finishes

Metal frame in white (RAL 9010), black (RAL 9005) or fluo orange (RAL 2005)
Power cable in black, red or orange (CE-only)
Shade in one layer of BuzziFelt
Color lace in black, white or fluorescent orange

Light

Excl. lightbulb
E27, max 60W (EU)
E26, max 100W (US)

Acoustics

Acoustic Principles

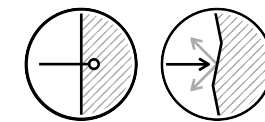

Absorption Diffusion

Acoustic Performance

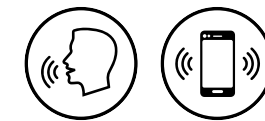

Mid Tones High Tones

How to order

Color frame
BuzziFelt color
Color lace
Color power cable

BuzziSol

— by BuzziSpace Studio

Shine bright

BuzziSol is a versatile and straightforward pendant light fixture. It can be fitted with a frosted glass globe for a decorative effect or with a reflector for more direct lighting. Both the LED Globe and the Spot are designed to complement existing acoustic lighting solutions, for instance, BuzziPleat, BuzziShade, BuzziProp, and more. Alternatively, use BuzziSol standalone as a unique lighting centerpiece. No boundaries!



Models

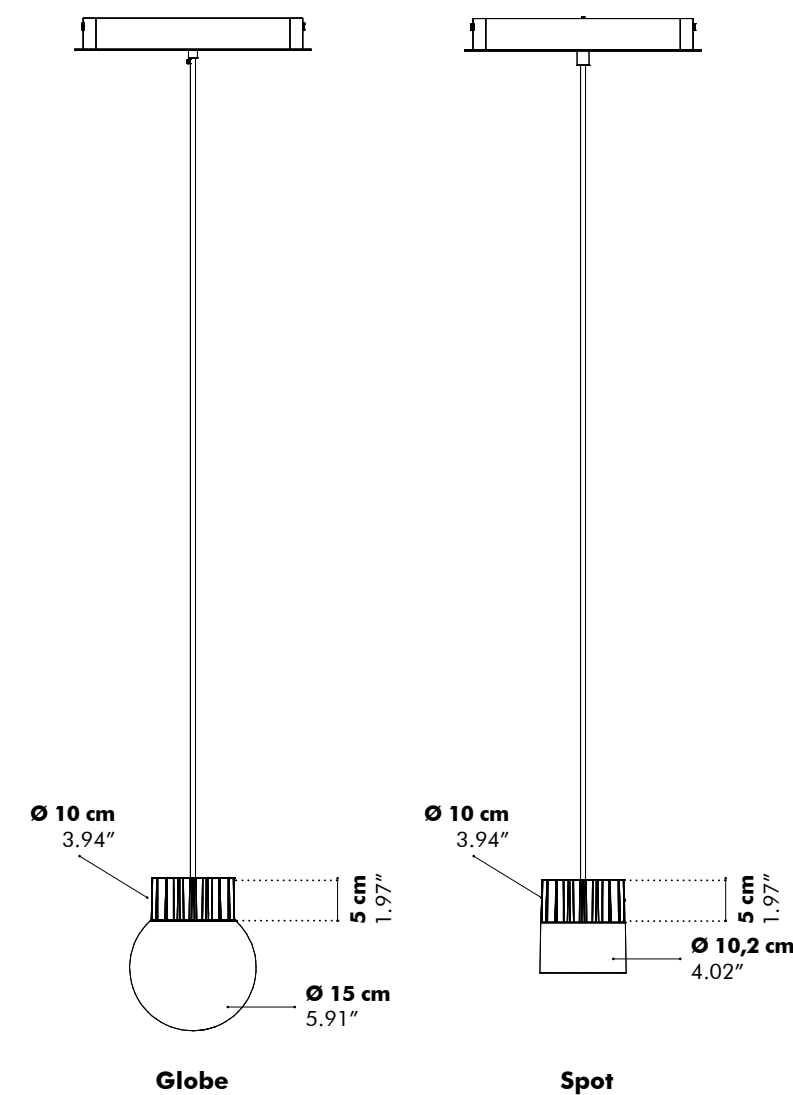

Finishes

Powder-coated metal heatsink in black (RAL 9005)
Black fabric power cable
(Check our application overview p. 330)

Mounting

Ceiling Suspended
Black metal ceiling canopy and black fabric cable incl.

Light

Frosted glass globe or reflector spot.
Input Voltage: 220 - 240V
Input Frequency: 50/60Hz
Lumen Output: 1500 Lm
Color Temperature: 3000K
Color Rendering Index: 90
Diffuser: Glass globe or Reflector spot
Dimming: 1-10V or Dali on request
CE/CB certified / cULus listed

LUX levels

To enlighten your space with optimal LUX levels take following measures into account.

Spot

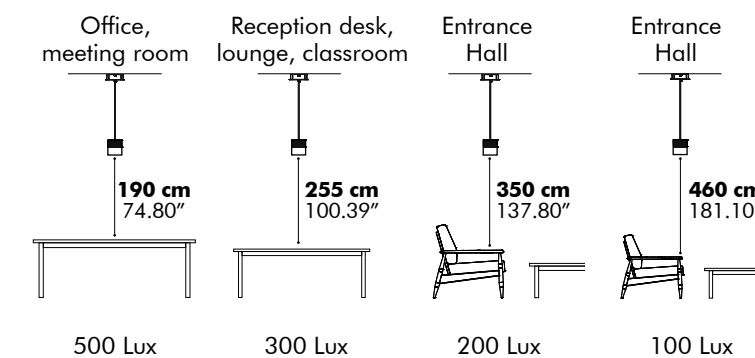

Globe

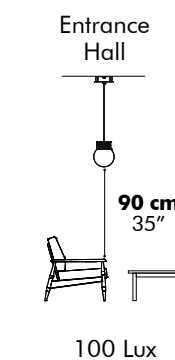

According to EN12464 (only on LUX levels) at full output

BuzziTrom

— by BuzziSpace Studio

Functional Lighting with acoustic abilities

BuzziTrom is the first functional acoustic lighting solution crafted from a dual layer of felt to join our lineup that works on speech and high-tones. Along with an integrated LED disk, this acoustic lighting pendant houses an enclosed 4 cm air cavity that ensures maximum acoustic performance. Its cylindrical design traps sound waves within the radius of its frame; meanwhile, the exterior helps to diffuse sound energy.

BuzziTrom features sturdy glossy bronze push buttons, giving the lighting option a modern twist. To add a playful touch, go for a bicolor variation, or keep things simple with a monotone outfit. BuzziTrom comes in three different sizes to suit your space. Choose from S to L.



Models

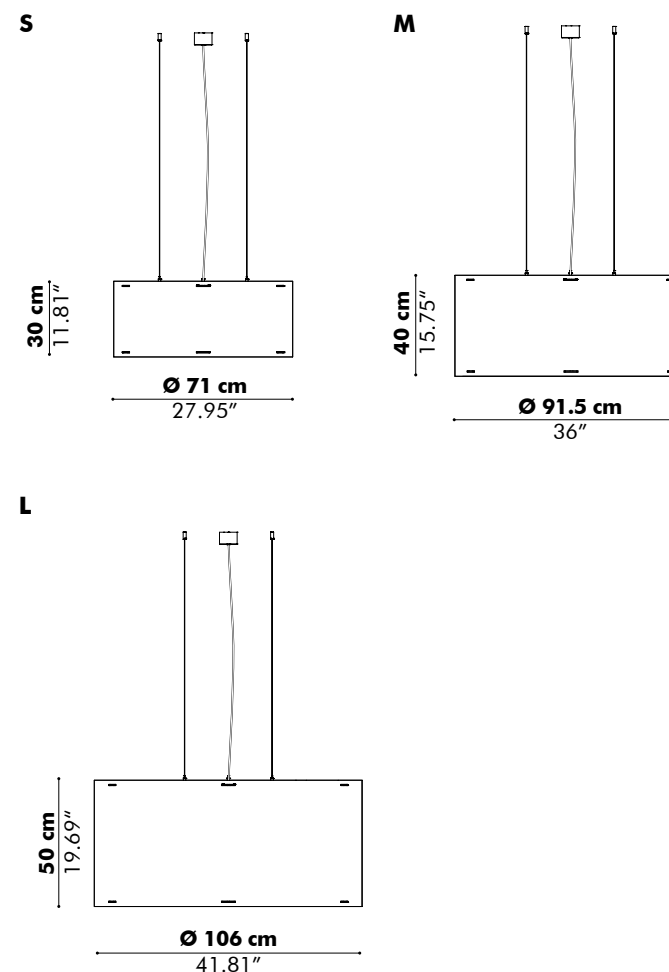

Finishes

Metal frame in black (RAL 9005)
Shade with an inside and outside layer of BuzziFelt finished with push buttons in glossy black.
(Check our application overview p. 330)

Options

Bicolor (inside or outside in different felt color)

Mounting

White metal ceiling canopy and transparent power cable incl.

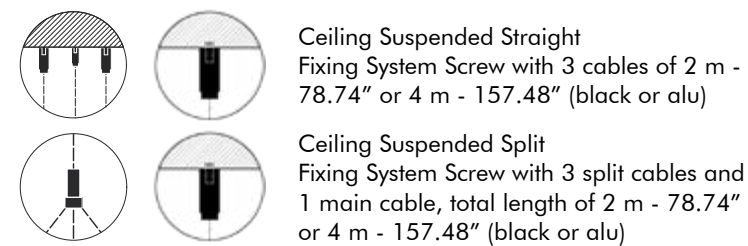

Light

Input Voltage: 220 - 240V
Input Frequency: 50/60Hz
Lumen output: 2545 Lm
Color temperature: 3000K / 4000K on request
Color Rendering Index: >90
Dimming: 1-10V or Dali (CE/CB)
Diffuser: milky (URG22) or prismatic (UGR19) on request
CE/CB certified / cULus listed (from end of summer 2020)
Dali on request

LUX levels

To enlighten your space with optimal LUX levels take following measures into account.

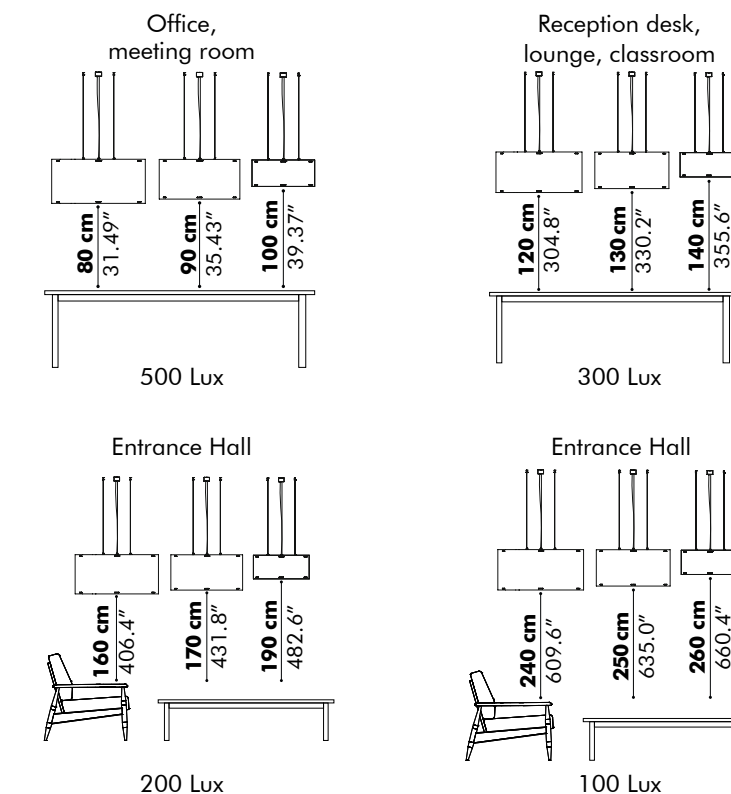

Acoustics

Acoustic Principles Acoustic Performance

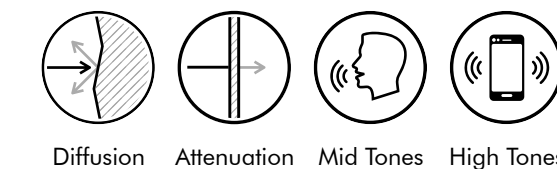

How to order

BuzziFelt Color inside
BuzziFelt Color outside
Mounting option
Available from end of summer 2020

BuzziZepp Light

— by Alain Gilles and BuzziSpace Studio

A suspended plane of light with sleek acoustic body

BuzziZepp is an impressive shield of light, offering acoustic control. The suspended design was conceived by designer Alain Gilles as an “imaginary island” to visually delineate and bring a sense of tranquility to large open spaces. With its striking linear design, BuzziZepp hovers from above to define zones without obstruction, establishing a more intimate, quiet and purposeful sense of space—no vertical partitions or walls needed! The slim framework is made of upholstered acoustic panels, engineered to absorb sound and reduce echo. The streamlined design is outfitted with dimmable LED lines, which can be adjusted for various situations. Dim the lights to set a more relaxed tone at your next meeting, or brighten your workstation to focus on the task at hand.



Models

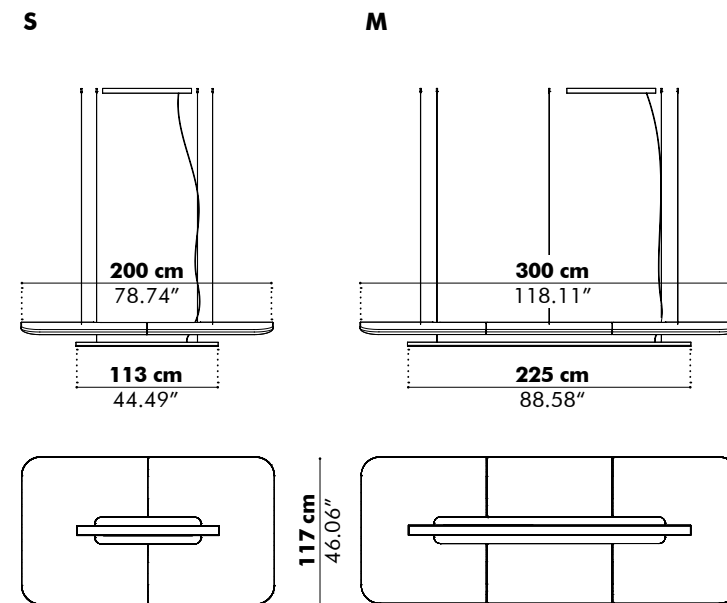



Finishes

Upholstery in fabric collections CAT A, B, C, D, E
(Check our application overview p. 330)
Black LED Line

Mounting

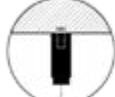
Black metal ceiling canopy and transparent power cable incl.

 Ceiling Suspended
Fixing System Screw with 6 or 8 cables of 2 m - 78.74" or 5 m - 196.85" (black or alu)

 The acoustic panel can be mounted straight or slanted, with a maximum angle of 20° to create a more secluded setting.

Light

Input Voltage: 110 - 240V
Input Frequency: 50/60Hz
Lumen Output small: 2300 Lm
Lumen Output medium: 4600 Lm
Color Temperature: 3000K / 4000K & 2700K on request
Color Rendering Index: 90
Dimming: 1-10V or Dali on request
CE/CB certified / cULus listed

LUX levels

To enlighten your space with optimal LUX levels take following measures into account.

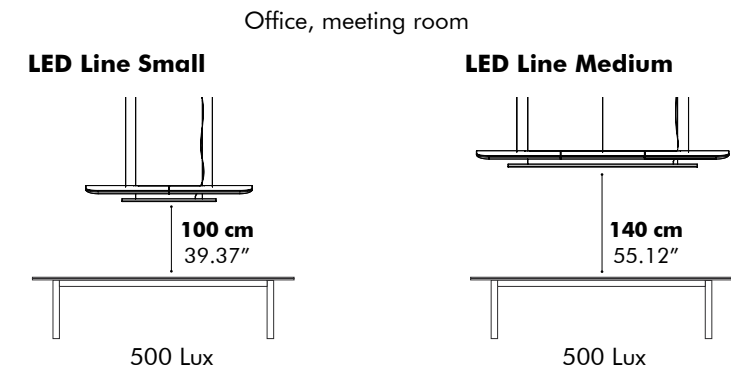

According to EN12464 (only on LUX levels)

Acoustics

Acoustic Principles

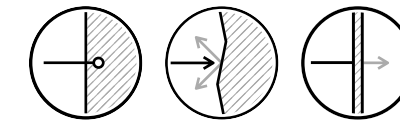

Absorption Diffusion Attenuation

Acoustic Performance



Low Tones Mid Tones High Tones

How to order

Size
Fabric (CAT > collection > color)
Mounting option

OUTDOOR

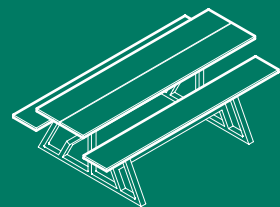

BuzziBreeze — 323

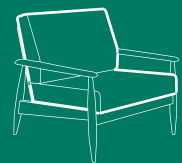

BuzziNordic ST900 — 324

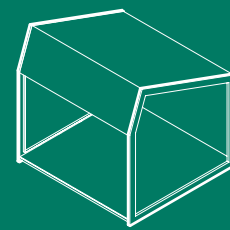

BuzziShed — 327

OUTDOOR

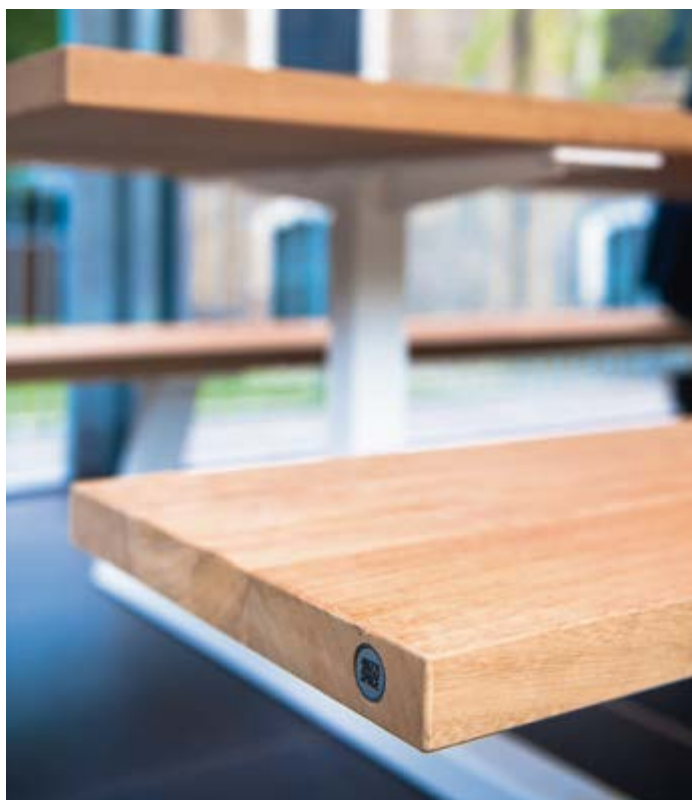

BuzziBreeze

— by BuzziSpace Studio in collaboration with Cassecroute

Outdoor workstation

BuzziSpace has always had a penchant for picnics, which is why it created the BuzziPicNic. This award-winning indoor table has all the nostalgic design features of a traditional picnic table. Our love of outdoor living inspired our designers to create BuzziBreeze, answering the call for an outdoor workstation that captures the collaborative needs of the modern workplace. BuzziBreeze is constructed using a powder coated metal frame, with the top and seat in weather-resistant hardwood or aluminum.

Models

BuzziBreeze

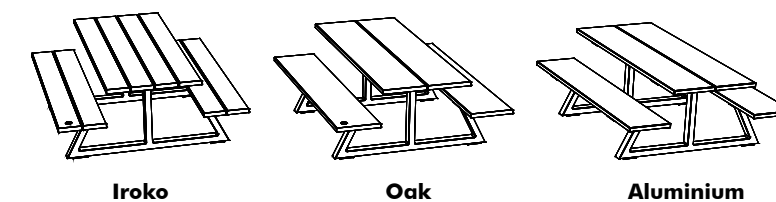

Iroko

Oak

Aluminium

Dimensions

BuzziBreeze

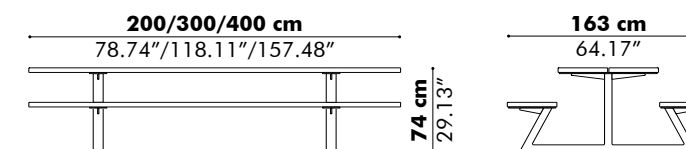

Finishes

Base in powder coated steel black (RAL 9005) or white (RAL 9010)
Worktop & seats in powder coated aluminum black (RAL 9005) or white (RAL 9010), Oak* or Iroko.

Iroko wood is naturally durable but may be prone to movement and cracking in outdoor environments.

How to order

Model
Length
Color base
Material worktop & seats

*Not suitable for outdoor use

BuzziNordic ST900

— Ståffan Thomasen

Outdoor zen

Vintage-inspired furniture should not be limited to the indoors. The BuzziNordic ST900 Collection gives you the opportunity to upgrade your outdoor space with a Scandinavian look and feel. Choose among several models; a single armchair, a matching ottoman and a daybed, all built on a frame of solid hardwood, suitable for the outdoors. Each style is outfitted with upholstered cushions in a variety of outdoor weather-proof fabrics, so you can choose to enjoy the open air year-round.



Models

ST911

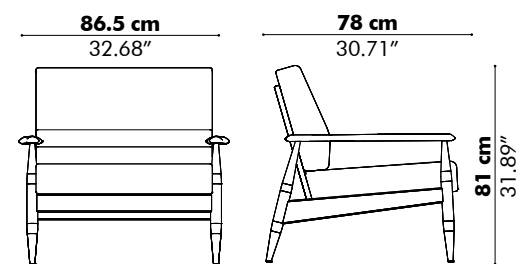

ST911 Ottoman

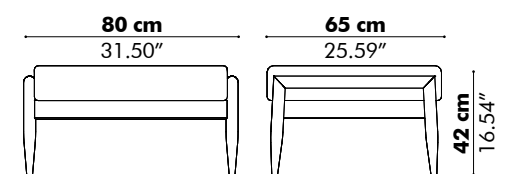

ST931 Daybed

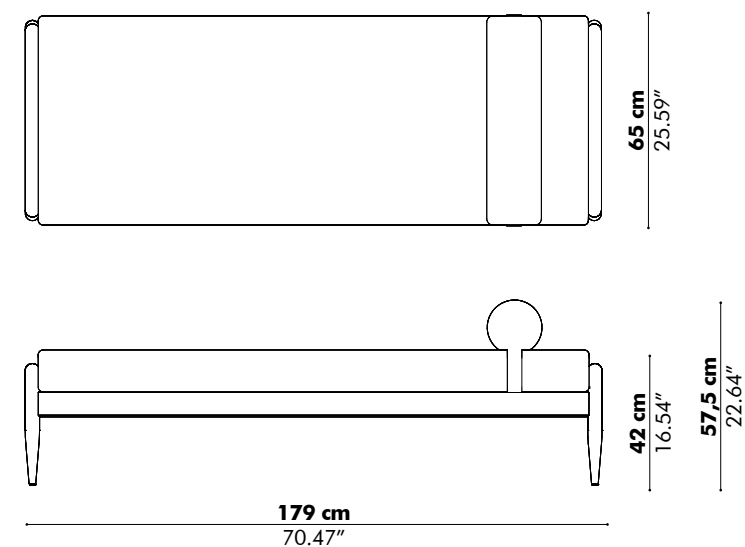

Finishes

Frame in Cumaru

Upholstery in outdoor fabric (check our website)

How to order

Model

Fabric (CAT > Collection > Color)





BuzziShed

— Jean-Pierre Galeyn and
BuzziSpace Studio

Outdoor shed

While working outside might seem nice, the lack of comfy furniture and the glare of the sun on your laptop or smartphone screen might cause a lot of discomfort. Until now. With the launch of the BuzziShed, designed by Jean Pierre Galeyn and BuzziSpace Studio, you can now work or spend time outside in this stylish outdoor shed, protected from sunlight and even from the rain. The BuzziShed can also be used as a garden shed on cool or rainy days or to create meeting points in a large open space.

Models

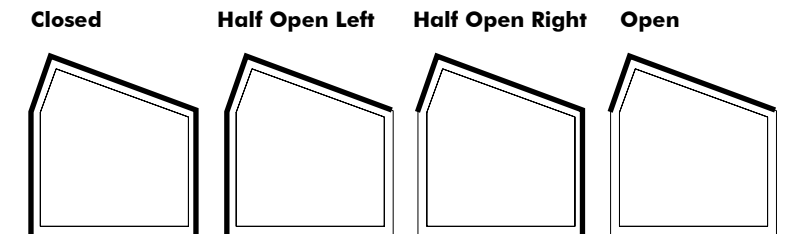

Dimensions

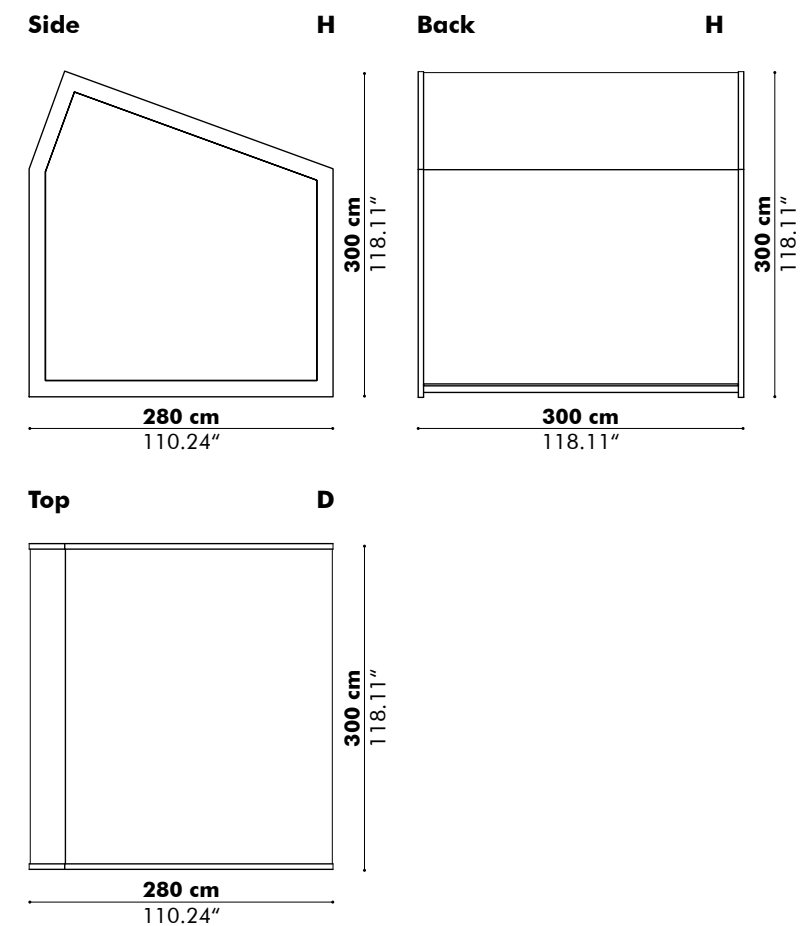

Options

Gutter available to connect two sheds (not possible with closed shed)
Custom fabric print on request

Finishes

Frame in galvanized steel
Roof in orchestra fabric (check our website)
Floor in antiskid outdoor plywood

How to order

Model
Color orchestra fabric
Options

MATERIALS

Upholstery	330
Curtains	368
Solid Materials	380

MATERIALS

UPHOLSTERY

FELTS, FABRICS & LEATHER

332 - 347 Application overview

348 - 353 Felt

- 348 BuzziFelt
- 349 Sliced BuzziFelt
- 352 BuzziFelt Printed

354 - 357 Category A

- 355 Fabric
- 356 Trevira CS | Trevira CS+
- 357 Revive 1

358 - 363 Category B

- 359 Clara 2
- 360 Remix 3
- 362 Velvet

364 Category C

- 364 Hero

365 Category D

- 365 Tonus 4

366 Category E

- 366 Memory 2

367 Leather

- 367 Vegetal



APPLICATION OVERVIEW

Felts, Fabrics & Leather

- Not possible
- Possible
- Sliced BuzziFelt

Product	Felt		Felt Printed	Leather	CAT A			
			Vegetal		Fabric	Trevira CS ⁺	Trevira CS [*]	Revive 1 ^{**}
	100% Recycl P.E.T. Felt	100% Recycl P.E.T. Felt	100% Leather		75% Recycled Wool 25% Recycled Polyacryl	100% Trevira	100% Trevira	100% Recycl. polyester FR
BuzziBack	<input checked="" type="radio"/>	<input type="radio"/>	<input type="radio"/>	<input type="radio"/>	<input checked="" type="radio"/>	<input checked="" type="radio"/>	<input checked="" type="radio"/>	<input checked="" type="radio"/>
BuzziBalance	<input type="radio"/>	<input type="radio"/>	<input type="radio"/>	<input type="radio"/>	<input checked="" type="radio"/>	<input checked="" type="radio"/>	<input checked="" type="radio"/>	<input checked="" type="radio"/>
BuzziBell	<input checked="" type="radio"/>	<input type="radio"/>	<input type="radio"/>	<input type="radio"/>	<input type="radio"/>	<input type="radio"/>	<input type="radio"/>	<input type="radio"/>
BuzziBlinds Classic	<input checked="" type="radio"/>	<input checked="" type="radio"/>	<input type="radio"/>	<input type="radio"/>	<input checked="" type="radio"/>	<input checked="" type="radio"/>	<input checked="" type="radio"/>	<input checked="" type="radio"/>
BuzziBlinds	Plain	<input checked="" type="radio"/>	<input type="radio"/>	<input type="radio"/>	<input checked="" type="radio"/>	<input checked="" type="radio"/>	<input checked="" type="radio"/>	<input checked="" type="radio"/>
	Lines	<input checked="" type="radio"/>	<input type="radio"/>	<input type="radio"/>	<input type="radio"/>	<input type="radio"/>	<input type="radio"/>	<input type="radio"/>
BuzziBlox	<input type="radio"/>	<input type="radio"/>	<input type="radio"/>	<input type="radio"/>	<input checked="" type="radio"/>	<input checked="" type="radio"/>	<input checked="" type="radio"/>	<input checked="" type="radio"/>
BuzziBoard	<input checked="" type="radio"/>	<input type="radio"/>	<input type="radio"/>	<input type="radio"/>	<input type="radio"/>	<input type="radio"/>	<input type="radio"/>	<input type="radio"/>
BuzziBooth	Single	<input type="radio"/>	<input type="radio"/>	<input type="radio"/>	<input checked="" type="radio"/>	<input checked="" type="radio"/>	<input type="radio"/>	<input type="radio"/>
	Standing	<input type="radio"/>	<input type="radio"/>	<input type="radio"/>	<input checked="" type="radio"/>	<input checked="" type="radio"/>	<input type="radio"/>	<input type="radio"/>
BuzziBooth Targa	H 120	<input type="radio"/>	<input type="radio"/>	<input type="radio"/>	<input checked="" type="radio"/>	<input checked="" type="radio"/>	<input checked="" type="radio"/>	<input type="radio"/>
	H 135	<input type="radio"/>	<input type="radio"/>	<input type="radio"/>	<input checked="" type="radio"/>	<input checked="" type="radio"/>	<input type="radio"/>	<input type="radio"/>
BuzziBounce	<input type="radio"/>	<input type="radio"/>	<input type="radio"/>	<input type="radio"/>	<input checked="" type="radio"/>	<input checked="" type="radio"/>	<input checked="" type="radio"/>	<input checked="" type="radio"/>
BuzziBox	<input checked="" type="radio"/>	<input type="radio"/>	<input type="radio"/>	<input type="radio"/>	<input type="radio"/>	<input type="radio"/>	<input type="radio"/>	<input type="radio"/>
BuzziBox Travel	<input checked="" type="radio"/>	<input type="radio"/>	<input type="radio"/>	<input type="radio"/>	<input type="radio"/>	<input type="radio"/>	<input type="radio"/>	<input type="radio"/>
BuzziBrickBack	<input checked="" type="radio"/>	<input type="radio"/>	<input type="radio"/>	<input type="radio"/>	<input type="radio"/>	<input type="radio"/>	<input type="radio"/>	<input type="radio"/>
BuzziBrickBack Architectural	<input checked="" type="radio"/>	<input type="radio"/>	<input type="radio"/>	<input type="radio"/>	<input type="radio"/>	<input type="radio"/>	<input type="radio"/>	<input type="radio"/>
BuzziCactus	<input type="radio"/>	<input type="radio"/>	<input type="radio"/>	<input type="radio"/>	<input checked="" type="radio"/>	<input checked="" type="radio"/>	<input checked="" type="radio"/>	<input type="radio"/>
BuzziCane	<input type="radio"/>	<input type="radio"/>	<input type="radio"/>	<input type="radio"/>	<input checked="" type="radio"/>	<input checked="" type="radio"/>	<input checked="" type="radio"/>	<input checked="" type="radio"/>
BuzziChandelier	<input checked="" type="radio"/>	<input type="radio"/>	<input type="radio"/>	<input type="radio"/>	<input type="radio"/>	<input type="radio"/>	<input type="radio"/>	<input type="radio"/>
BuzziClipse	<input type="radio"/>	<input type="radio"/>	<input type="radio"/>	<input type="radio"/>	<input checked="" type="radio"/>	<input checked="" type="radio"/>	<input checked="" type="radio"/>	<input checked="" type="radio"/>
BuzziCone	<input checked="" type="radio"/>	<input type="radio"/>	<input type="radio"/>	<input type="radio"/>	<input checked="" type="radio"/>	<input type="radio"/>	<input type="radio"/>	<input type="radio"/>
BuzziCube	Flat	<input type="radio"/>	<input type="radio"/>	<input type="radio"/>	<input checked="" type="radio"/>	<input checked="" type="radio"/>	<input checked="" type="radio"/>	<input checked="" type="radio"/>
	3D	<input type="radio"/>	<input type="radio"/>	<input type="radio"/>	<input checked="" type="radio"/>	<input checked="" type="radio"/>	<input type="radio"/>	<input type="radio"/>
BuzziDee	Flat	<input type="radio"/>	<input type="radio"/>	<input type="radio"/>	<input checked="" type="radio"/>	<input checked="" type="radio"/>	<input checked="" type="radio"/>	<input checked="" type="radio"/>
	3D	<input type="radio"/>	<input type="radio"/>	<input type="radio"/>	<input checked="" type="radio"/>	<input checked="" type="radio"/>	<input checked="" type="radio"/>	<input checked="" type="radio"/>
BuzziDesk	<input checked="" type="radio"/>	<input type="radio"/>	<input type="radio"/>	<input type="radio"/>	<input checked="" type="radio"/>	<input checked="" type="radio"/>	<input checked="" type="radio"/>	<input checked="" type="radio"/>
BuzziDesk Cross	<input checked="" type="radio"/>	<input type="radio"/>	<input type="radio"/>	<input type="radio"/>	<input checked="" type="radio"/>	<input checked="" type="radio"/>	<input checked="" type="radio"/>	<input checked="" type="radio"/>
BuzziDesk FlipFlop	<input type="radio"/>	<input type="radio"/>	<input type="radio"/>	<input type="radio"/>	<input checked="" type="radio"/>	<input checked="" type="radio"/>	<input checked="" type="radio"/>	<input checked="" type="radio"/>
BuzziDesk Split	<input checked="" type="radio"/>	<input type="radio"/>	<input type="radio"/>	<input type="radio"/>	<input type="radio"/>	<input type="radio"/>	<input type="radio"/>	<input type="radio"/>
BuzziDish	<input type="radio"/>	<input type="radio"/>	<input type="radio"/>	<input type="radio"/>	<input checked="" type="radio"/>	<input checked="" type="radio"/>	<input checked="" type="radio"/>	<input checked="" type="radio"/>
BuzziDome	<input type="radio"/>	<input type="radio"/>	<input type="radio"/>	<input type="radio"/>	<input checked="" type="radio"/>	<input checked="" type="radio"/>	<input checked="" type="radio"/>	<input type="radio"/>

*Trevira CS and Trevira CS+ contain organophosphorus chemicals used as "covered flame retardant" above a level of 1000ppm. Therefore these fabrics can't be used as upholstery cover material in US states that require compliance to California Assembly Bill No. 2998.

**Revive 1 contains organophosphorus chemicals used as "covered flame retardant" above a level of 1000ppm. Therefore this fabric can't be used as upholstery cover material in US states that require compliance to California Assembly Bill No. 2998.

APPLICATION OVERVIEW

Felts, Fabrics & Leather

- Not possible
- Possible
- Sliced BuzziFelt

Product	CAT B			CAT C	CAT D	CAT E
	Clara 2	Remix 3	Velvet	Hero	Tonus 4	Memory 2*
	92% New Wool worsted 8% Nylon	90% New Wool worsted 10% Nylon	100% polyester	96% New Wool 4% Nylon	90% New Wool 10% Helanca	100% Trevira CS
BuzziBack	<input checked="" type="radio"/>	<input checked="" type="radio"/>	<input checked="" type="radio"/>	<input checked="" type="radio"/>	<input checked="" type="radio"/>	<input checked="" type="radio"/>
BuzziBalance	<input checked="" type="radio"/>	<input checked="" type="radio"/>	<input checked="" type="radio"/>	<input checked="" type="radio"/>	<input checked="" type="radio"/>	<input checked="" type="radio"/>
BuzziBell	<input type="radio"/>	<input type="radio"/>	<input type="radio"/>	<input type="radio"/>	<input type="radio"/>	<input type="radio"/>
BuzziBlind Classic	<input checked="" type="radio"/>	<input checked="" type="radio"/>	<input checked="" type="radio"/>	<input checked="" type="radio"/>	<input checked="" type="radio"/>	<input checked="" type="radio"/>
BuzziBlind	No lines	<input checked="" type="radio"/>	<input checked="" type="radio"/>	<input checked="" type="radio"/>	<input checked="" type="radio"/>	<input checked="" type="radio"/>
	Lines	<input type="radio"/>	<input type="radio"/>	<input type="radio"/>	<input type="radio"/>	<input type="radio"/>
BuzziBlox	<input checked="" type="radio"/>	<input checked="" type="radio"/>	<input checked="" type="radio"/>	<input checked="" type="radio"/>	<input checked="" type="radio"/>	<input checked="" type="radio"/>
BuzziBoard	<input type="radio"/>	<input type="radio"/>	<input type="radio"/>	<input type="radio"/>	<input type="radio"/>	<input type="radio"/>
BuzziBooth	Single	<input type="radio"/>	<input type="radio"/>	<input type="radio"/>	<input type="radio"/>	<input checked="" type="radio"/>
	Standing	<input type="radio"/>	<input type="radio"/>	<input type="radio"/>	<input type="radio"/>	<input checked="" type="radio"/>
BuzziBooth Targa	H 120	<input checked="" type="radio"/>	<input checked="" type="radio"/>	<input type="radio"/>	<input checked="" type="radio"/>	<input checked="" type="radio"/>
	H 135	<input type="radio"/>	<input type="radio"/>	<input type="radio"/>	<input type="radio"/>	<input checked="" type="radio"/>
BuzziBounce	<input checked="" type="radio"/>	<input checked="" type="radio"/>	<input type="radio"/>	<input type="radio"/>	<input type="radio"/>	<input checked="" type="radio"/>
BuzziBox	<input type="radio"/>	<input type="radio"/>	<input type="radio"/>	<input type="radio"/>	<input type="radio"/>	<input type="radio"/>
BuzziBox Travel	<input type="radio"/>	<input type="radio"/>	<input type="radio"/>	<input type="radio"/>	<input type="radio"/>	<input type="radio"/>
BuzziBrickBack	<input type="radio"/>	<input type="radio"/>	<input type="radio"/>	<input type="radio"/>	<input type="radio"/>	<input type="radio"/>
BuzziBrickBack Architectural	<input type="radio"/>	<input type="radio"/>	<input type="radio"/>	<input type="radio"/>	<input type="radio"/>	<input type="radio"/>
BuzziCactus	<input checked="" type="radio"/>	<input checked="" type="radio"/>	<input type="radio"/>	<input checked="" type="radio"/>	<input checked="" type="radio"/>	<input checked="" type="radio"/>
BuzziCane	<input checked="" type="radio"/>	<input checked="" type="radio"/>	<input checked="" type="radio"/>	<input checked="" type="radio"/>	<input checked="" type="radio"/>	<input checked="" type="radio"/>
BuzziChandelier	<input type="radio"/>	<input type="radio"/>	<input type="radio"/>	<input type="radio"/>	<input type="radio"/>	<input type="radio"/>
BuzziClipse	<input checked="" type="radio"/>	<input checked="" type="radio"/>	<input checked="" type="radio"/>	<input checked="" type="radio"/>	<input checked="" type="radio"/>	<input checked="" type="radio"/>
BuzziCone	<input type="radio"/>	<input type="radio"/>	<input type="radio"/>	<input checked="" type="radio"/>	<input type="radio"/>	<input type="radio"/>
BuzziCube	Flat	<input checked="" type="radio"/>	<input checked="" type="radio"/>	<input checked="" type="radio"/>	<input checked="" type="radio"/>	<input checked="" type="radio"/>
	3D	<input type="radio"/>	<input type="radio"/>	<input type="radio"/>	<input type="radio"/>	<input checked="" type="radio"/>
BuzziDee	Flat	<input checked="" type="radio"/>	<input checked="" type="radio"/>	<input checked="" type="radio"/>	<input checked="" type="radio"/>	<input checked="" type="radio"/>
	3D	<input checked="" type="radio"/>	<input checked="" type="radio"/>	<input type="radio"/>	<input checked="" type="radio"/>	<input checked="" type="radio"/>
BuzziDesk	<input checked="" type="radio"/>	<input checked="" type="radio"/>	<input checked="" type="radio"/>	<input checked="" type="radio"/>	<input checked="" type="radio"/>	<input checked="" type="radio"/>
BuzziDesk Cross	<input checked="" type="radio"/>	<input checked="" type="radio"/>	<input checked="" type="radio"/>	<input checked="" type="radio"/>	<input checked="" type="radio"/>	<input checked="" type="radio"/>
BuzziDesk FlipFlop	<input checked="" type="radio"/>	<input checked="" type="radio"/>	<input checked="" type="radio"/>	<input checked="" type="radio"/>	<input checked="" type="radio"/>	<input checked="" type="radio"/>
BuzziDesk Split	<input type="radio"/>	<input type="radio"/>	<input type="radio"/>	<input type="radio"/>	<input type="radio"/>	<input type="radio"/>
BuzziDish	<input checked="" type="radio"/>	<input checked="" type="radio"/>	<input type="radio"/>	<input checked="" type="radio"/>	<input checked="" type="radio"/>	<input checked="" type="radio"/>
BuzziDome	<input checked="" type="radio"/>	<input checked="" type="radio"/>	<input type="radio"/>	<input checked="" type="radio"/>	<input checked="" type="radio"/>	<input checked="" type="radio"/>

* Memory 2 contains organophosphorus chemicals used as "covered flame retardant" above a level of 1000ppm. Therefore this fabric can't be used as upholstery cover material in US states that require compliance to California Assembly Bill No. 2998.

APPLICATION OVERVIEW

Felts, Fabrics & Leather

- Not possible
- ✔ Possible
- Ⓢ Sliced BuzziFelt

Product			Felt	Felt Printed	Leather	CAT A			
					Vegetal	Fabric	Trevira CS ⁺⁺	Trevira CS ⁺	Revive 1 ^{**}
			100% Recycl P.E.T. Felt	100% Recycl P.E.T. Felt	100% Leather	75% Recycled Wool 25% Recycled Polyacryl	100% Trevira	100% Trevira	100% Recycl. polyester FR
BuzziDonut			○	○	○	✔	✔	✔	✔
BuzziFalls			✔	✔	○	○	○	○	○
BuzziFalls Standing			✔	✔	○	○	○	○	○
BuzziFloat			○	○	✔	✔	✔	✔	✔
BuzziFree	H ≤ 120 cm	W ≤ 200 cm	✔	○	○	✔	✔	✔	✔
	H ≤ 140 cm	W ≤ 120 cm	✔	○	○	✔	✔	✔	✔
	H ≤ 140 cm	W ≤ 200 cm	✔	○	○	✔	✔	○	○
	H ≤ 160 cm	W ≤ 120 cm	✔	○	○	✔	✔	✔	✔
	H ≤ 160 cm	W ≤ 140 cm	✔	○	○	✔	✔	○	○
	H ≤ 160 cm	W ≤ 180 cm	✔	○	○	○	○	○	○
	H ≤ 180 cm	W ≤ 120 cm	✔	○	○	✔	✔	✔	✔
	H ≤ 180 cm	W ≤ 140 cm	✔	○	○	✔	✔	○	○
	H ≤ 180 cm	W ≤ 180 cm	✔	○	○	○	○	○	○
BuzziFrio			✔	○	○	✔	✔	✔	✔
BuzziFrontDesk			✔	○	○	✔	✔	✔	✔
BuzziGrid			✔	○	○	○	○	○	○
BuzziGrip			✔	○	○	○	○	○	○
BuzziHat			○	○	○	✔	✔	✔	✔
BuzziHive			○	○	○	✔	✔	✔	✔
BuzziHood	Flat		○	○	○	✔	✔	✔	✔
	3D		○	○	○	✔	✔	✔	✔
BuzziHub	Hub		○	○	○	✔	✔	○	○
	Side		○	○	○	✔	✔	○	○
	Single		○	○	○	✔	✔	○	○
	Bench		○	○	○	✔	✔	✔	✔
	Cushion		○	○	○	✔	✔	✔	✔
	Armrest		○	○	○	✔	✔	✔	✔
BuzziHub Table	Acoustic layer		✔	○	○	○	○	○	○
BuzziHug			○	○	○	✔	✔	✔	✔
BuzziJet			○	○	○	✔	✔	✔	✔
BuzziJet Standing			○	○	○	✔	✔	✔	✔
BuzziKey Soft			○	○	○	✔	✔	✔	✔
BuzziLand	Oval / Round Flat		○	○	○	✔	✔	✔	✔
	Oval / Round 3D		○	○	○	✔	✔	✔	✔
BuzziLight Mono			✔	○	○	○	○	○	○
BuzziLoose	Flat		✔	○	○	✔	✔	✔	✔
	3D		○	○	○	✔	✔	✔	✔

*Trevira CS and Trevira CS+ contain organophosphorus chemicals used as “covered flame retardant” above a level of 1000ppm. Therefore these fabrics can’t be used as upholstery cover material in US states that require compliance to California Assembly Bill No. 2998.

**Revive 1 contains organophosphorus chemicals used as “covered flame retardant” above a level of 1000ppm. Therefore this fabric can’t be used as upholstery cover material in US states that require compliance to California Assembly Bill No. 2998.

Find the latest update of the application overview on our website: www.buzzi.space

APPLICATION OVERVIEW

Felts, Fabrics & Leather

- Not possible
- Possible
- ⊗ Sliced BuzziFelt

Product			CAT B			CAT C	CAT D	CAT E
			Clara 2	Remix 3	Velvet	Hero	Tonus 4	Memory 2 [*]
			92% New Wool worsted 8% Nylon	90% New Wool worsted 10% Nylon	100% polyester	96% New Wool 4% Nylon	90% New Wool 10% Helanca	100% Trevira CS
BuzziDonut			●	●	○	●	●	●
BuzziFalls			○	○	○	○	○	○
BuzziFalls Standing			○	○	○	○	○	○
BuzziFloat			●	●	●	●	●	●
BuzziFree	H ≤ 120 cm	W ≤ 200 cm	●	●	●	●	●	●
	H ≤ 140 cm	W ≤ 120 cm	●	●	●	●	●	●
	H ≤ 140 cm	W ≤ 200 cm	○	○	○	○	○	●
	H ≤ 160 cm	W ≤ 120 cm	●	●	●	●	●	●
	H ≤ 160 cm	W ≤ 140 cm	○	○	○	○	○	●
	H ≤ 160 cm	W ≤ 180 cm	○	○	○	○	○	○
	H ≤ 180 cm	W ≤ 120 cm	●	●	●	●	●	●
	H ≤ 180 cm	W ≤ 140 cm	○	○	○	○	○	●
	H ≤ 180 cm	W ≤ 180 cm	○	○	○	○	○	
BuzziFrio			●	●	●	●	●	●
BuzziFrontDesk			●	●	○	●	●	●
BuzziGrid			○	○	○	○	○	○
BuzziGrip			○	○	○	○	○	○
BuzziHat			●	●	●	●	●	●
BuzziHive			●	●	○	●	●	●
BuzziHood	Flat		●	●	○	●	●	●
	3D		●	●	○	●	●	●
BuzziHub	Hub		○	○	○	○	○	●
	Side		○	○	○	○	○	●
	Single		○	○	○	○	○	●
	Bench		●	●	○	●	●	●
	Cushion		●	●	○	●	●	●
	Armrest		●	●	○	●	●	●
BuzziHub Table	Acoustic layer		○	○	○	○	○	○
BuzziHug			●	●	○	●	●	●
BuzziJet			●	●	○	●	●	●
BuzziJet Standing			●	●	○	●	●	●
BuzziKey Soft			●	●	●	●	●	●
BuzziLand	Oval / Round Flat		●	●	○	●	●	●
	Oval / Round 3D		●	●	○	●	●	●
BuzziLight Mono			○	○	○	○	○	○
BuzziLoose	Flat		●	●	○	●	●	●
	3D		●	●	○	●	●	●

^{*} Memory 2 contains organophosphorus chemicals used as "covered flame retardant" above a level of 1000ppm. Therefore this fabric can't be used as upholstery cover material in US states that require compliance to California Assembly Bill No. 2998.

Find the latest update of the application overview on our website: www.buzzi.space

APPLICATION OVERVIEW

Felts, Fabrics & Leather

- Not possible
- Possible
- Sliced BuzziFelt

Product		Felt	Felt Printed	Leather	CAT A			
				Vegetal	Fabric	Trevira CS ⁺⁺	Trevira CS [*]	Revive 1 ^{**}
		100% Recycl PE.T. Felt	100% Recycl PE.T. Felt	100% Leather	75% Recycled Wool 25% Recycled Polyacryl	100% Trevira	100% Trevira	100% Recycl. polyester FR
BuzziMe		<input type="radio"/>	<input type="radio"/>	<input type="radio"/>	<input checked="" type="radio"/>	<input checked="" type="radio"/>	<input checked="" type="radio"/>	<input checked="" type="radio"/>
BuzziMilk		<input type="radio"/>	<input type="radio"/>	<input checked="" type="radio"/>	<input checked="" type="radio"/>	<input checked="" type="radio"/>	<input checked="" type="radio"/>	<input checked="" type="radio"/>
BuzziMood		<input type="radio"/>	<input type="radio"/>	<input type="radio"/>	<input checked="" type="radio"/>	<input checked="" type="radio"/>	<input checked="" type="radio"/>	<input checked="" type="radio"/>
BuzziMoon		<input type="radio"/>	<input type="radio"/>	<input type="radio"/>	<input checked="" type="radio"/>	<input checked="" type="radio"/>	<input checked="" type="radio"/>	<input checked="" type="radio"/>
BuzziNest	Exterior	<input type="radio"/>	<input type="radio"/>	<input type="radio"/>	<input checked="" type="radio"/>	<input checked="" type="radio"/>	<input type="radio"/>	<input type="radio"/>
	Interior	<input checked="" type="radio"/>	<input checked="" type="radio"/>	<input type="radio"/>	<input checked="" type="radio"/>	<input checked="" type="radio"/>	<input type="radio"/>	<input type="radio"/>
BuzziNordic	ST101	<input type="radio"/>	<input type="radio"/>	<input checked="" type="radio"/>	<input checked="" type="radio"/>	<input checked="" type="radio"/>	<input checked="" type="radio"/>	<input checked="" type="radio"/>
	ST111	<input type="radio"/>	<input type="radio"/>	<input checked="" type="radio"/>	<input checked="" type="radio"/>	<input checked="" type="radio"/>	<input checked="" type="radio"/>	<input checked="" type="radio"/>
	ST102	<input type="radio"/>	<input type="radio"/>	<input checked="" type="radio"/>	<input checked="" type="radio"/>	<input checked="" type="radio"/>	<input checked="" type="radio"/>	<input checked="" type="radio"/>
	ST103	<input type="radio"/>	<input type="radio"/>	<input checked="" type="radio"/>	<input checked="" type="radio"/>	<input checked="" type="radio"/>	<input checked="" type="radio"/>	<input checked="" type="radio"/>
	ST101 Ottoman	<input type="radio"/>	<input type="radio"/>	<input checked="" type="radio"/>	<input checked="" type="radio"/>	<input checked="" type="radio"/>	<input checked="" type="radio"/>	<input checked="" type="radio"/>
	ST111 Ottoman	<input type="radio"/>	<input type="radio"/>	<input checked="" type="radio"/>	<input checked="" type="radio"/>	<input checked="" type="radio"/>	<input checked="" type="radio"/>	<input checked="" type="radio"/>
	ST101 Footstool	<input type="radio"/>	<input type="radio"/>	<input checked="" type="radio"/>	<input checked="" type="radio"/>	<input checked="" type="radio"/>	<input checked="" type="radio"/>	<input checked="" type="radio"/>
BuzziPicNic	Desk High Connect Panel	<input checked="" type="radio"/>	<input type="radio"/>	<input type="radio"/>	<input type="radio"/>	<input type="radio"/>	<input type="radio"/>	<input type="radio"/>
	Bench Cushion	<input type="radio"/>	<input type="radio"/>	<input type="radio"/>	<input checked="" type="radio"/>	<input checked="" type="radio"/>	<input checked="" type="radio"/>	<input checked="" type="radio"/>
BuzziPlant		<input type="radio"/>	<input type="radio"/>	<input type="radio"/>	<input checked="" type="radio"/>	<input checked="" type="radio"/>	<input checked="" type="radio"/>	
BuzziPlanter		<input type="radio"/>	<input type="radio"/>	<input type="radio"/>	<input checked="" type="radio"/>	<input checked="" type="radio"/>	<input checked="" type="radio"/>	
BuzziPleat		<input checked="" type="radio"/>	<input type="radio"/>	<input type="radio"/>	<input checked="" type="radio"/>	<input type="radio"/>	<input type="radio"/>	
BuzziPleat Light		<input checked="" type="radio"/>	<input type="radio"/>	<input type="radio"/>	<input type="radio"/>	<input type="radio"/>	<input type="radio"/>	
BuzziPouf	Flat	<input type="radio"/>	<input type="radio"/>	<input type="radio"/>	<input checked="" type="radio"/>	<input checked="" type="radio"/>	<input checked="" type="radio"/>	<input checked="" type="radio"/>
	3D	<input type="radio"/>	<input type="radio"/>	<input type="radio"/>	<input checked="" type="radio"/>	<input checked="" type="radio"/>	<input checked="" type="radio"/>	<input checked="" type="radio"/>
BuzziProp		<input type="radio"/>	<input type="radio"/>	<input type="radio"/>	<input checked="" type="radio"/>	<input checked="" type="radio"/>	<input checked="" type="radio"/>	
BuzziPuzzle		<input type="radio"/>	<input type="radio"/>	<input type="radio"/>	<input checked="" type="radio"/>	<input checked="" type="radio"/>	<input checked="" type="radio"/>	
BuzziRing		<input type="radio"/>	<input type="radio"/>	<input type="radio"/>	<input type="radio"/>	<input checked="" type="radio"/>	<input checked="" type="radio"/>	
BuzziScreen		<input checked="" type="radio"/>	<input checked="" type="radio"/>	<input type="radio"/>	<input checked="" type="radio"/>	<input checked="" type="radio"/>	<input checked="" type="radio"/>	
BuzziScreen Mix		<input checked="" type="radio"/>	<input checked="" type="radio"/>	<input type="radio"/>	<input checked="" type="radio"/>	<input checked="" type="radio"/>	<input checked="" type="radio"/>	
BuzziShade	Pendant	<input checked="" type="radio"/>	<input type="radio"/>	<input type="radio"/>	<input checked="" type="radio"/>	<input type="radio"/>	<input type="radio"/>	<input type="radio"/>
	Standing	<input checked="" type="radio"/>	<input type="radio"/>	<input type="radio"/>	<input type="radio"/>	<input type="radio"/>	<input type="radio"/>	<input type="radio"/>
	Square	<input checked="" type="radio"/>	<input type="radio"/>	<input type="radio"/>	<input type="radio"/>	<input type="radio"/>	<input type="radio"/>	<input type="radio"/>
BuzziShield Desk		<input type="radio"/>	<input type="radio"/>	<input type="radio"/>	<input checked="" type="radio"/>	<input checked="" type="radio"/>	<input checked="" type="radio"/>	
BuzziShield Free		<input type="radio"/>	<input type="radio"/>	<input type="radio"/>	<input checked="" type="radio"/>	<input checked="" type="radio"/>	<input checked="" type="radio"/>	
BuzziShield Hook		<input type="radio"/>	<input type="radio"/>	<input type="radio"/>	<input checked="" type="radio"/>	<input checked="" type="radio"/>	<input checked="" type="radio"/>	
BuzziSkin		<input checked="" type="radio"/>	<input type="radio"/>	<input type="radio"/>	<input type="radio"/>	<input type="radio"/>	<input type="radio"/>	
BuzziSkin Cuts		<input checked="" type="radio"/>	<input type="radio"/>	<input type="radio"/>	<input type="radio"/>	<input type="radio"/>	<input type="radio"/>	
BuzziSkin Printed		<input checked="" type="radio"/>	<input type="radio"/>	<input type="radio"/>	<input type="radio"/>	<input type="radio"/>	<input type="radio"/>	
BuzziSpark	Shields	<input type="radio"/>	<input type="radio"/>	<input type="radio"/>	<input checked="" type="radio"/>	<input checked="" type="radio"/>	<input checked="" type="radio"/>	<input type="radio"/>
	Cushions	<input type="radio"/>	<input type="radio"/>	<input checked="" type="radio"/>	<input checked="" type="radio"/>	<input checked="" type="radio"/>	<input checked="" type="radio"/>	<input checked="" type="radio"/>

*Trevira CS and Trevira CS+ contain organophosphorus chemicals used as "covered flame retardant" above a level of 1000ppm. Therefore these fabrics can't be used as upholstery cover material in US states that require compliance to California Assembly Bill No. 2998.

** Revive 1 contains organophosphorus chemicals used as "covered flame retardant" above a level of 1000ppm. Therefore this fabric can't be used as upholstery cover material in US states that require compliance to California Assembly Bill No. 2998.

Find the latest update of the application overview on our website: www.buzzi.space

APPLICATION OVERVIEW

Felts, Fabrics & Leather

- Not possible
- Possible
- Sliced BuzziFelt

Product		CAT B			CAT C	CAT D	CAT E
		Clara 2	Remix 3	Velvet	Hero	Tonus 4	Memory 2*
		92% New Wool worsted 8% Nylon	90% New Wool worsted 10% Nylon	100% polyester	96% New Wool 4% Nylon	90% New Wool 10% Helanca	100% Trevira CS
BuzziMe		<input checked="" type="radio"/>	<input checked="" type="radio"/>	<input checked="" type="radio"/>	<input checked="" type="radio"/>	<input checked="" type="radio"/>	<input checked="" type="radio"/>
BuzziMilk		<input checked="" type="radio"/>	<input checked="" type="radio"/>	<input checked="" type="radio"/>	<input checked="" type="radio"/>	<input checked="" type="radio"/>	<input checked="" type="radio"/>
BuzziMood		<input checked="" type="radio"/>	<input checked="" type="radio"/>	<input type="radio"/>	<input checked="" type="radio"/>	<input checked="" type="radio"/>	<input checked="" type="radio"/>
BuzziMoon		<input checked="" type="radio"/>	<input checked="" type="radio"/>	<input type="radio"/>	<input checked="" type="radio"/>	<input checked="" type="radio"/>	<input checked="" type="radio"/>
BuzziNest	Exterior	<input type="radio"/>	<input type="radio"/>	<input type="radio"/>	<input type="radio"/>	<input type="radio"/>	<input type="radio"/>
	Interior	<input type="radio"/>	<input type="radio"/>	<input type="radio"/>	<input type="radio"/>	<input type="radio"/>	<input type="radio"/>
BuzziNordic	ST101	<input checked="" type="radio"/>	<input checked="" type="radio"/>	<input checked="" type="radio"/>	<input checked="" type="radio"/>	<input checked="" type="radio"/>	<input checked="" type="radio"/>
	ST111	<input checked="" type="radio"/>	<input checked="" type="radio"/>	<input checked="" type="radio"/>	<input checked="" type="radio"/>	<input checked="" type="radio"/>	<input checked="" type="radio"/>
	ST102	<input checked="" type="radio"/>	<input checked="" type="radio"/>	<input checked="" type="radio"/>	<input checked="" type="radio"/>	<input checked="" type="radio"/>	<input checked="" type="radio"/>
	ST103	<input checked="" type="radio"/>	<input checked="" type="radio"/>	<input checked="" type="radio"/>	<input checked="" type="radio"/>	<input checked="" type="radio"/>	<input checked="" type="radio"/>
	ST101 Ottoman	<input checked="" type="radio"/>	<input checked="" type="radio"/>	<input checked="" type="radio"/>	<input checked="" type="radio"/>	<input checked="" type="radio"/>	<input checked="" type="radio"/>
	ST111 Ottoman	<input checked="" type="radio"/>	<input checked="" type="radio"/>	<input checked="" type="radio"/>	<input checked="" type="radio"/>	<input checked="" type="radio"/>	<input checked="" type="radio"/>
	ST101 Footstool	<input checked="" type="radio"/>	<input checked="" type="radio"/>	<input checked="" type="radio"/>	<input checked="" type="radio"/>	<input checked="" type="radio"/>	<input checked="" type="radio"/>
BuzziPicNic	Desk High Connect Panel	<input type="radio"/>	<input type="radio"/>	<input type="radio"/>	<input type="radio"/>	<input type="radio"/>	<input type="radio"/>
	Bench Cushion	<input checked="" type="radio"/>	<input checked="" type="radio"/>	<input checked="" type="radio"/>	<input checked="" type="radio"/>	<input checked="" type="radio"/>	<input checked="" type="radio"/>
BuzziPlant		<input checked="" type="radio"/>	<input checked="" type="radio"/>	<input type="radio"/>	<input checked="" type="radio"/>	<input checked="" type="radio"/>	<input checked="" type="radio"/>
BuzziPlanter		<input checked="" type="radio"/>	<input checked="" type="radio"/>	<input type="radio"/>	<input checked="" type="radio"/>	<input checked="" type="radio"/>	<input checked="" type="radio"/>
BuzziPleat		<input type="radio"/>	<input type="radio"/>	<input type="radio"/>	<input type="radio"/>	<input type="radio"/>	<input type="radio"/>
BuzziPleat Light		<input type="radio"/>	<input type="radio"/>	<input type="radio"/>	<input type="radio"/>	<input type="radio"/>	<input type="radio"/>
BuzziPouf	Flat	<input checked="" type="radio"/>	<input checked="" type="radio"/>	<input checked="" type="radio"/>	<input checked="" type="radio"/>	<input checked="" type="radio"/>	<input checked="" type="radio"/>
	3D	<input checked="" type="radio"/>	<input checked="" type="radio"/>	<input type="radio"/>	<input checked="" type="radio"/>	<input checked="" type="radio"/>	<input checked="" type="radio"/>
BuzziProp		<input checked="" type="radio"/>	<input checked="" type="radio"/>	<input type="radio"/>	<input checked="" type="radio"/>	<input checked="" type="radio"/>	<input checked="" type="radio"/>
BuzziPuzzle		<input checked="" type="radio"/>	<input checked="" type="radio"/>	<input checked="" type="radio"/>	<input checked="" type="radio"/>	<input checked="" type="radio"/>	<input checked="" type="radio"/>
BuzziRing		<input checked="" type="radio"/>	<input type="radio"/>	<input type="radio"/>	<input checked="" type="radio"/>	<input checked="" type="radio"/>	<input checked="" type="radio"/>
BuzziScreen		<input checked="" type="radio"/>	<input checked="" type="radio"/>	<input checked="" type="radio"/>	<input checked="" type="radio"/>	<input checked="" type="radio"/>	<input checked="" type="radio"/>
BuzziScreen Mix		<input checked="" type="radio"/>	<input checked="" type="radio"/>	<input checked="" type="radio"/>	<input checked="" type="radio"/>	<input checked="" type="radio"/>	<input checked="" type="radio"/>
BuzziShade	Pendant	<input type="radio"/>	<input type="radio"/>	<input type="radio"/>	<input checked="" type="radio"/>	<input type="radio"/>	<input type="radio"/>
	Standing	<input type="radio"/>	<input type="radio"/>	<input type="radio"/>	<input type="radio"/>	<input type="radio"/>	<input type="radio"/>
	Square	<input type="radio"/>	<input type="radio"/>	<input type="radio"/>	<input type="radio"/>	<input type="radio"/>	<input type="radio"/>
BuzziShield Desk		<input checked="" type="radio"/>	<input checked="" type="radio"/>	<input checked="" type="radio"/>	<input checked="" type="radio"/>	<input checked="" type="radio"/>	<input checked="" type="radio"/>
BuzziShield Free		<input checked="" type="radio"/>	<input checked="" type="radio"/>	<input checked="" type="radio"/>	<input checked="" type="radio"/>	<input checked="" type="radio"/>	<input checked="" type="radio"/>
BuzziShield Hook		<input checked="" type="radio"/>	<input checked="" type="radio"/>	<input type="radio"/>	<input checked="" type="radio"/>	<input checked="" type="radio"/>	<input checked="" type="radio"/>
BuzziSkin		<input type="radio"/>	<input type="radio"/>	<input type="radio"/>	<input type="radio"/>	<input type="radio"/>	<input type="radio"/>
BuzziSkin Cuts		<input type="radio"/>	<input type="radio"/>	<input type="radio"/>	<input type="radio"/>	<input type="radio"/>	<input type="radio"/>
BuzziSkin Printed		<input type="radio"/>	<input type="radio"/>	<input type="radio"/>	<input type="radio"/>	<input type="radio"/>	<input type="radio"/>
BuzziSpark	Shield	<input checked="" type="radio"/>	<input type="radio"/>	<input checked="" type="radio"/>	<input checked="" type="radio"/>	<input checked="" type="radio"/>	<input checked="" type="radio"/>
	Cushions	<input checked="" type="radio"/>	<input checked="" type="radio"/>	<input checked="" type="radio"/>	<input checked="" type="radio"/>	<input checked="" type="radio"/>	<input checked="" type="radio"/>

* Memory 2 contains organophosphorus chemicals used as "covered flame retardant" above a level of 1000ppm. Therefore this fabric can't be used as upholstery cover material in US states that require compliance to California Assembly Bill No. 2998.

Find the latest update of the application overview on our website: www.buzzi.space

APPLICATION OVERVIEW

Felts, Fabrics & Leather

- Not possible
- Possible
- Sliced BuzziFelt

Product		Felt	Felt Printed	Leather	CAT A			
				Vegetal	Fabric	Trevira CS ⁺	Trevira CS [*]	Revive 1 ^{**}
		100% Recycl PE.T. Felt	100% Recycl PE.T. Felt	100% Leather	75% Recycled Wool 25% Recycled Polyacryl	100% Trevira	100% Trevira	100% Recycl. polyester FR
BuzziSpot	Flat	<input type="radio"/>	<input type="radio"/>	<input type="radio"/>	<input checked="" type="radio"/>	<input checked="" type="radio"/>	<input checked="" type="radio"/>	<input checked="" type="radio"/>
	3D	<input type="radio"/>	<input type="radio"/>	<input type="radio"/>	<input checked="" type="radio"/>	<input checked="" type="radio"/>	<input checked="" type="radio"/>	<input checked="" type="radio"/>
BuzziTab Soft		<input type="radio"/>	<input type="radio"/>	<input type="radio"/>	<input checked="" type="radio"/>	<input checked="" type="radio"/>	<input checked="" type="radio"/>	<input checked="" type="radio"/>
BuzziTemp		<input type="radio"/>	<input type="radio"/>	<input type="radio"/>	<input checked="" type="radio"/>	<input checked="" type="radio"/>	<input checked="" type="radio"/>	<input checked="" type="radio"/>
BuzziTile	Flat	<input type="radio"/>	<input type="radio"/>	<input type="radio"/>	<input checked="" type="radio"/>	<input checked="" type="radio"/>	<input checked="" type="radio"/>	<input checked="" type="radio"/>
	3D	<input type="radio"/>	<input type="radio"/>	<input type="radio"/>	<input checked="" type="radio"/>	<input checked="" type="radio"/>	<input checked="" type="radio"/>	<input checked="" type="radio"/>
BuzziTotem		<input type="radio"/>	<input type="radio"/>	<input type="radio"/>	<input checked="" type="radio"/>	<input checked="" type="radio"/>	<input checked="" type="radio"/>	<input checked="" type="radio"/>
BuzziTripl Desk		<input checked="" type="radio"/>	<input type="radio"/>	<input type="radio"/>	<input type="radio"/>	<input type="radio"/>	<input type="radio"/>	<input type="radio"/>
BuzziTripl Desk Split		<input checked="" type="radio"/>	<input type="radio"/>	<input type="radio"/>	<input type="radio"/>	<input type="radio"/>	<input type="radio"/>	<input type="radio"/>
BuzziTripl Desk Wrap		<input checked="" type="radio"/>	<input type="radio"/>	<input type="radio"/>	<input type="radio"/>	<input type="radio"/>	<input type="radio"/>	<input type="radio"/>
BuzziTripl Home		<input checked="" type="radio"/>	<input type="radio"/>	<input type="radio"/>	<input type="radio"/>	<input type="radio"/>	<input type="radio"/>	<input type="radio"/>
BuzziTrom		<input checked="" type="radio"/>	<input type="radio"/>	<input type="radio"/>	<input type="radio"/>	<input type="radio"/>	<input type="radio"/>	<input type="radio"/>
BuzziTwist		<input checked="" type="radio"/>	<input type="radio"/>	<input type="radio"/>	<input type="radio"/>	<input type="radio"/>	<input type="radio"/>	<input type="radio"/>
BuzziVille	Panel H 120 cm	<input type="radio"/>	<input type="radio"/>	<input type="radio"/>	<input checked="" type="radio"/>	<input checked="" type="radio"/>	<input checked="" type="radio"/>	<input checked="" type="radio"/>
	Panel H 135 cm	<input type="radio"/>	<input type="radio"/>	<input type="radio"/>	<input checked="" type="radio"/>	<input checked="" type="radio"/>	<input type="radio"/>	<input type="radio"/>
	Panel H 150 cm	<input type="radio"/>	<input type="radio"/>	<input type="radio"/>	<input checked="" type="radio"/>	<input checked="" type="radio"/>	<input type="radio"/>	<input type="radio"/>
	Panel H 180 cm	<input type="radio"/>	<input type="radio"/>	<input type="radio"/>	<input checked="" type="radio"/>	<input checked="" type="radio"/>	<input type="radio"/>	<input type="radio"/>
	Bench	<input type="radio"/>	<input type="radio"/>	<input type="radio"/>	<input checked="" type="radio"/>	<input checked="" type="radio"/>	<input checked="" type="radio"/>	<input type="radio"/>
	Booth / Booth Standing	<input type="radio"/>	<input type="radio"/>	<input type="radio"/>	<input checked="" type="radio"/>	<input checked="" type="radio"/>	<input type="radio"/>	<input type="radio"/>
	Hub	<input type="radio"/>	<input type="radio"/>	<input type="radio"/>	<input checked="" type="radio"/>	<input checked="" type="radio"/>	<input type="radio"/>	<input type="radio"/>
	Hub Open	<input type="radio"/>	<input type="radio"/>	<input type="radio"/>	<input checked="" type="radio"/>	<input checked="" type="radio"/>	<input type="radio"/>	<input type="radio"/>
	Split Panel	<input type="radio"/>	<input type="radio"/>	<input type="radio"/>	<input checked="" type="radio"/>	<input checked="" type="radio"/>	<input checked="" type="radio"/>	<input checked="" type="radio"/>
BuzziWings		<input checked="" type="radio"/>	<input type="radio"/>	<input type="radio"/>	<input checked="" type="radio"/>	<input checked="" type="radio"/>	<input checked="" type="radio"/>	<input checked="" type="radio"/>
BuzziWrap Desk		<input checked="" type="radio"/>	<input type="radio"/>	<input type="radio"/>	<input type="radio"/>	<input type="radio"/>	<input type="radio"/>	<input type="radio"/>
BuzziWrap FrontDesk		<input checked="" type="radio"/>	<input type="radio"/>	<input type="radio"/>	<input type="radio"/>	<input type="radio"/>	<input type="radio"/>	<input type="radio"/>
BuzziZepp		<input type="radio"/>	<input type="radio"/>	<input type="radio"/>	<input checked="" type="radio"/>	<input checked="" type="radio"/>	<input checked="" type="radio"/>	<input checked="" type="radio"/>
BuzziZepp Light		<input type="radio"/>	<input type="radio"/>	<input type="radio"/>	<input checked="" type="radio"/>	<input checked="" type="radio"/>	<input checked="" type="radio"/>	<input checked="" type="radio"/>

*Trevira CS and Trevira CS+ contain organophosphorus chemicals used as "covered flame retardant" above a level of 1000ppm. Therefore these fabrics can't be used as upholstery cover material in US states that require compliance to California Assembly Bill No. 2998.

**Revive 1 contains organophosphorus chemicals used as "covered flame retardant" above a level of 1000ppm. Therefore this fabric can't be used as upholstery cover material in US states that require compliance to California Assembly Bill No. 2998.

Find the latest update of the application overview on our website: www.buzzi.space

APPLICATION OVERVIEW

Felts, Fabrics & Leather

- Not possible
- Possible
- Sliced BuzziFelt

Product		CAT B			CAT C	CAT D	CAT E
		Clara 2	Remix 3	Velvet	Hero	Tonus 4	Memory 2*
		92% New Wool worsted 8% Nylon	90% New Wool worsted 10% Nylon	100% polyester	96% New Wool 4% Nylon	90% New Wool 10% Helanca	100% Trevira CS
BuzziSpot	Flat	<input checked="" type="radio"/>	<input checked="" type="radio"/>	<input checked="" type="radio"/>	<input checked="" type="radio"/>	<input checked="" type="radio"/>	<input checked="" type="radio"/>
	3D	<input checked="" type="radio"/>	<input checked="" type="radio"/>	<input type="radio"/>	<input checked="" type="radio"/>	<input checked="" type="radio"/>	<input checked="" type="radio"/>
BuzziTab Soft		<input checked="" type="radio"/>	<input checked="" type="radio"/>	<input checked="" type="radio"/>	<input checked="" type="radio"/>	<input checked="" type="radio"/>	<input checked="" type="radio"/>
BuzziTemp		<input checked="" type="radio"/>	<input checked="" type="radio"/>	<input type="radio"/>	<input checked="" type="radio"/>	<input checked="" type="radio"/>	<input checked="" type="radio"/>
BuzziTile	Flat	<input checked="" type="radio"/>	<input checked="" type="radio"/>	<input type="radio"/>	<input checked="" type="radio"/>	<input checked="" type="radio"/>	<input checked="" type="radio"/>
	3D	<input checked="" type="radio"/>	<input checked="" type="radio"/>	<input type="radio"/>	<input checked="" type="radio"/>	<input checked="" type="radio"/>	<input checked="" type="radio"/>
BuzziTotem		<input checked="" type="radio"/>	<input checked="" type="radio"/>	<input checked="" type="radio"/>	<input checked="" type="radio"/>	<input checked="" type="radio"/>	<input checked="" type="radio"/>
BuzziTripl Desk		<input type="radio"/>	<input type="radio"/>	<input type="radio"/>	<input type="radio"/>	<input type="radio"/>	<input type="radio"/>
BuzziTripl Desk Split		<input type="radio"/>	<input type="radio"/>	<input type="radio"/>	<input type="radio"/>	<input type="radio"/>	<input type="radio"/>
BuzziTripl Wrap		<input type="radio"/>	<input type="radio"/>	<input type="radio"/>	<input type="radio"/>	<input type="radio"/>	<input type="radio"/>
BuzziTripl Home		<input type="radio"/>	<input type="radio"/>	<input type="radio"/>	<input type="radio"/>	<input type="radio"/>	<input type="radio"/>
BuzziTrom		<input type="radio"/>	<input type="radio"/>	<input type="radio"/>	<input type="radio"/>	<input type="radio"/>	<input type="radio"/>
BuzziTwist		<input type="radio"/>	<input type="radio"/>	<input type="radio"/>	<input type="radio"/>	<input type="radio"/>	<input type="radio"/>
BuzziVille	Panel H 120 cm	<input checked="" type="radio"/>	<input checked="" type="radio"/>	<input type="radio"/>	<input type="radio"/>	<input type="radio"/>	<input type="radio"/>
	Panel H 135 cm	<input type="radio"/>	<input type="radio"/>	<input type="radio"/>	<input type="radio"/>	<input type="radio"/>	<input type="radio"/>
	Panel H 150 cm	<input type="radio"/>	<input type="radio"/>	<input type="radio"/>	<input type="radio"/>	<input type="radio"/>	<input type="radio"/>
	Panel H 180 cm	<input type="radio"/>	<input type="radio"/>	<input type="radio"/>	<input type="radio"/>	<input type="radio"/>	<input type="radio"/>
	Bench	<input type="radio"/>	<input type="radio"/>	<input type="radio"/>	<input type="radio"/>	<input type="radio"/>	<input type="radio"/>
	Booth / Booth Standing	<input type="radio"/>	<input type="radio"/>	<input type="radio"/>	<input type="radio"/>	<input type="radio"/>	<input type="radio"/>
	Hub	<input type="radio"/>	<input type="radio"/>	<input type="radio"/>	<input type="radio"/>	<input type="radio"/>	<input type="radio"/>
	Hub Open	<input type="radio"/>	<input type="radio"/>	<input type="radio"/>	<input type="radio"/>	<input type="radio"/>	<input type="radio"/>
Split Panel	<input checked="" type="radio"/>	<input checked="" type="radio"/>	<input type="radio"/>	<input type="radio"/>	<input type="radio"/>	<input type="radio"/>	
BuzziWings		<input checked="" type="radio"/>	<input checked="" type="radio"/>	<input checked="" type="radio"/>	<input checked="" type="radio"/>	<input checked="" type="radio"/>	<input checked="" type="radio"/>
BuzziWrap Desk		<input type="radio"/>	<input type="radio"/>	<input type="radio"/>	<input type="radio"/>	<input type="radio"/>	<input type="radio"/>
BuzziWrap FrontDesk		<input type="radio"/>	<input type="radio"/>	<input type="radio"/>	<input type="radio"/>	<input type="radio"/>	<input type="radio"/>
BuzziZepp		<input checked="" type="radio"/>	<input checked="" type="radio"/>	<input checked="" type="radio"/>	<input checked="" type="radio"/>	<input checked="" type="radio"/>	<input checked="" type="radio"/>
BuzziZepp Light		<input checked="" type="radio"/>	<input checked="" type="radio"/>	<input checked="" type="radio"/>	<input checked="" type="radio"/>	<input checked="" type="radio"/>	<input checked="" type="radio"/>

* Memory 2 contains organophosphorus chemicals used as "covered flame retardant" above a level of 1000ppm. Therefore this fabric can't be used as upholstery cover material in US states that require compliance to California Assembly Bill No. 2998.

Find the latest update of the application overview on our website: www.buzzi.space

FELT

BUZZIFELT
BUZZIFELT PRINTED
SLICED BUZZIFELT

BuzziFelt



FE-Anthracite 68

Composition 100% Recycled PE.T. Felt, latex backing
Weight 1.000 g/m² | 29.49 oz/yd²
Width 170 cm | 66.93"
Thickness 6 mm | 0.236"
Abrasion resistance >7.000 Martindale
Flammability EU: EN 13501.1 + A1/2009 Class B-s1,d0
 USA: ASTM E84 Class A certified
Fastness to light EU: 6-7 | USA 5 Vacuum clean regularly. Don't wash. Don't remove the BuzziFelt from the product. Treat spillages immediately. Professional dry clean or wipe clean with a pH neutral soap and a damp cloth.



Sliced BuzziFelt

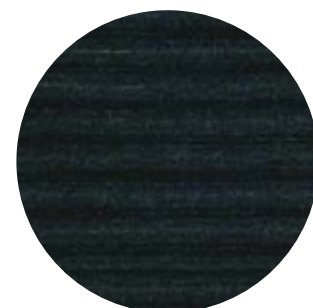

Anthracite | Anthracite

Composition 100% Recycled PE.T. Felt
 Vacuum clean regularly. Don't wash. Don't remove the Sliced BuzziFelt from the product. Treat spillages immediately. Professional dry clean or wipe clean with a pH neutral soap and a damp cloth.



FELT

BUZZIFELT
SLICED BUZZIFELT
BUZZIFELT PRINTED

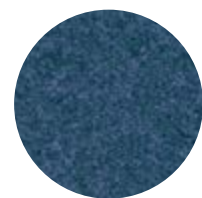

FE-Jeans 75

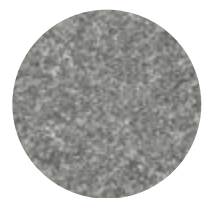

FE-StoneGrey 67

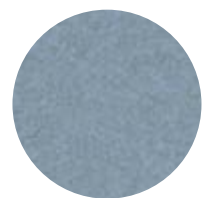

FE-LightBlue 60

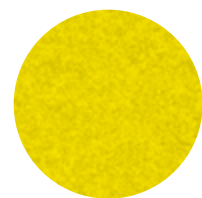

FE-Curry 61



FE-OffWhite 63



FE-Mokka 74



FE-EcoBrown 58



FE-Lime 64



FE-Pink 65



FE-Orange 66



FE-Red 59

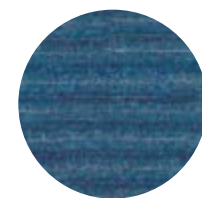

Jeans | Jeans

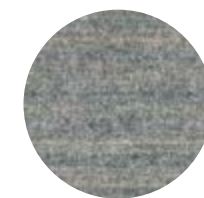

StoneGrey | StoneGrey

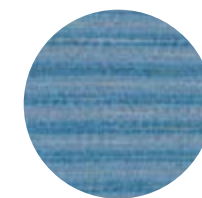

LightBlue | LightBlue



Curry | Curry



OffWhite | OffWhite



Mokka | Mokka

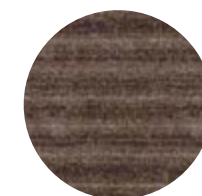

EcoBrown | EcoBrown

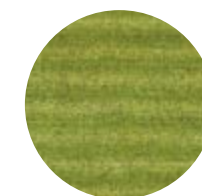

Lime | Lime

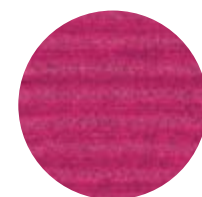

Pink | Pink

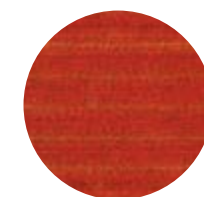

Orange | Orange



Red | Red

Note color deviation may occur.
 Find the latest update of the material specifications and colors on our website:
www.buzzi.space

Note color deviation may occur.
 Find the latest update of the material specifications and colors on our website:
www.buzzi.space

FELT

BUZZIFELT
SLICED BUZZIFELT
BUZZIFELT PRINTED

Bicolor



OffWhite | Anthracite



OffWhite | Jeans

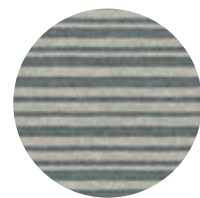

Offwhite | StoneGrey

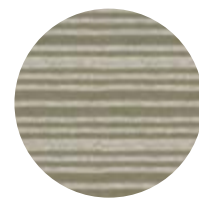

OffWhite | Mokka

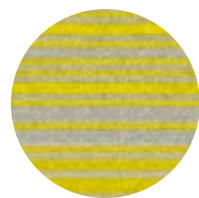

OffWhite | Curry

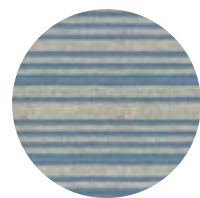

Offwhite | LightBlue



OffWhite | EcoBrown

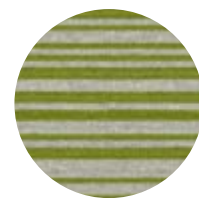

OffWhite | Lime

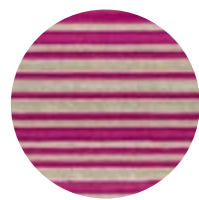

OffWhite | Pink



OffWhite | Orange



OffWhite | Red

Multicolor

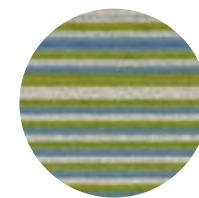

Grass

LightBlue
OffWhite
Lime

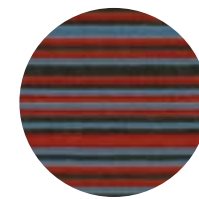

Savannah

LightBlue
EcoBrown
Orange

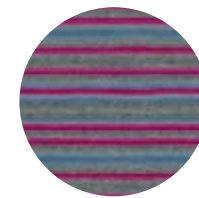

Colibri

LightBlue
StoneGrey
Pink

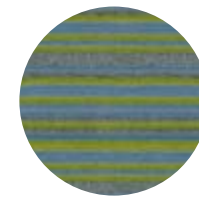

Toendra

LightBlue
StoneGrey
Lime

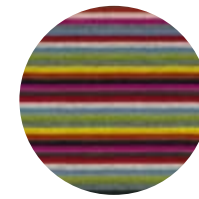

Tukan

LightBlue
Lime
StoneGrey
Red
EcoBrown
Orange
Pink
Anthracite
OffWhite
Curry

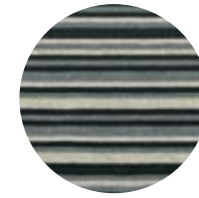

Zebra

Anthracite
StoneGrey
OffWhite



Jane

Anthracite
StoneGrey
OffWhite
White
Red
EcoBrown



Sigma

Anthracite
StoneGrey
OffWhite
White
Orange
EcoBrown

FELT

BUZZIFELT
SLICED BUZZIFELT
BUZZIFELT PRINTED

Note color deviation may occur.
Find the latest update of the material
specifications and colors on our website:
www.buzzi.space

FELT

BUZZIFELT
BUZZIFELT PRINTED
SLICED BUZZIFELT

BuzziFelt Printed



Jungle

Composition 100% Recycled PE.T. Felt, latex backing
Weight 1.000 g/m² | 29.49 oz/yd²
Width 170 cm | 66.93"
Thickness 6 mm | 0.236"
Abrasion resistance >7.000 Martindale
Flammability EU: EN 13501.1 + A1/2009 Class B-s1,d0
 USA: ASTM E84 Class A certified
Fastness to light EU: 6-7 | USA 5
Maintenance Vacuum clean regularly. Don't wash. Don't remove the BuzziFelt from the product. Treat spillages immediately. Professional dry clean or wipe clean with a pH neutral soap and a damp cloth.

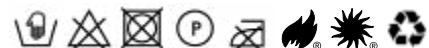

Camo Amazon



Camo Desert



Camo Snow



Camo Taiga



Concrete

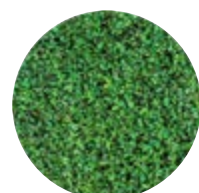

Green 1



Green 2

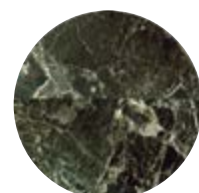

Marble Absynth

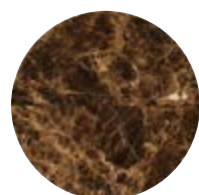

Marble Emperador

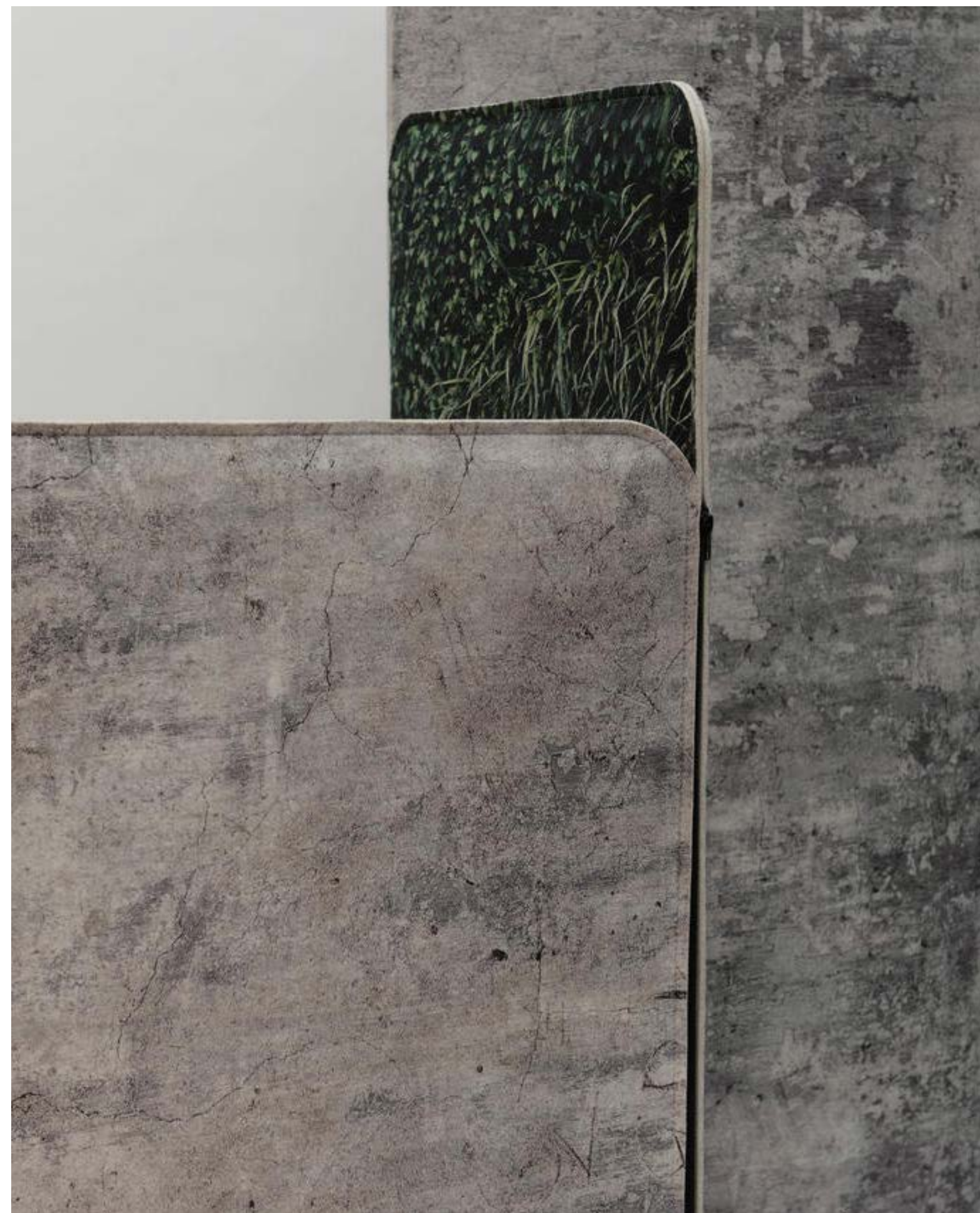



Fabric

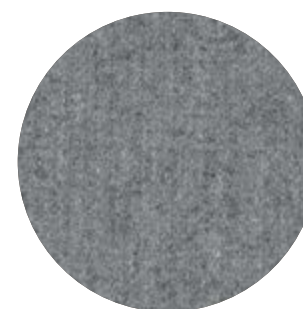

FA-LightGrey
1000

Composition 75% Recycled Wool, 25% Recycled Polyacryl,
Weight 405 g/m² | 11.94 oz/yd²
Width 148 cm | 58.27"
Thickness 0,8 mm | 0.031 inch
Abrasion resistance 40.000 Martindale, 50.000 Wyzenbeek
Flammability EU: EN 1021.1/2006 | BS EN 1021.1/2006 (cigarette)
 EN 1021.2/2006 | BS EN 1021.2/2006 (match)
 USA: CAL TB 117 | ASTM E84 CLASS A
Fastness to light EU: 4 | USA: 4
Fastness to rubbing EU: Wet 3-4 | Dry 4-5
Fastness to crocking USA: Wet 5 | Dry 5
Maintenance Vacuum clean regularly. Don't wash. Don't remove the
 Fabric from the product. Treat spillages immediately. Professional dry clean
 or wipe clean with a pH neutral soap and a damp cloth.

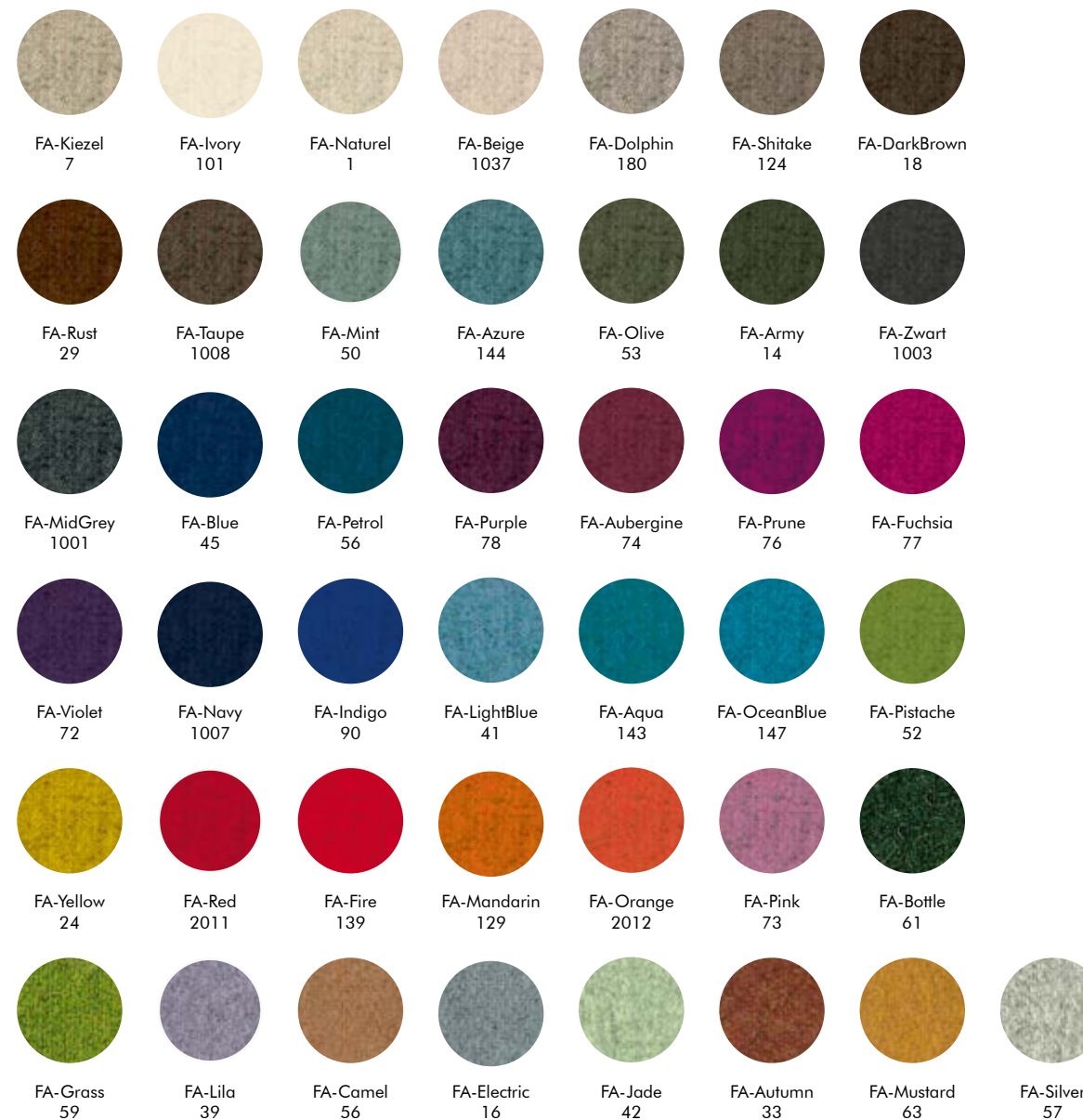

CAT A
 FABRIC
 TREVIRA CS+
 TREVIRA CS
 REVIVE 1

Note color deviation may occur.
 Find the latest update of the material
 specifications and colors on our website:
www.buzzi.space

CAT A

FABRIC
TREVIRA CS+
TREVIRA CS
REVIVE 1

Trevira CS+ | Trevira CS

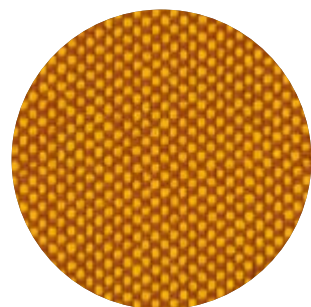

TRCS+ Hazy Mocca 9302

Composition 100% Polyester, Trevira CS
Weight 420 g/m² | 12.39 oz/yd²
Width Trevira CS+ 150 cm | 59.06" - Trevira CS 140 cm | 55.12"
Abrasion resistance 100.000 Martindale, 90.000 Wyzenbeek
Flammability EU: BS 5852 part II: CRIB 5 | BS 7176 Medium Hazard
 M1 | B1 | C1 | EN 1021/1-2 | IMO Res. A652 (16)
 USA: CAL TB 117*
Fastness to light EU: 6 | USA: 5
Fastness to rubbing EU: Wet 4-5 | Dry 4-5
Fastness to crocking USA: Wet 5 | Dry 5
Match Weight ±5% | Width ±2%
Maintenance Vacuum clean regularly. Don't remove the Trevira CS+ | Trevira CS from the product. Treat spillages immediately. Professional dry clean or wipe clean with a pH neutral soap and a damp cloth.

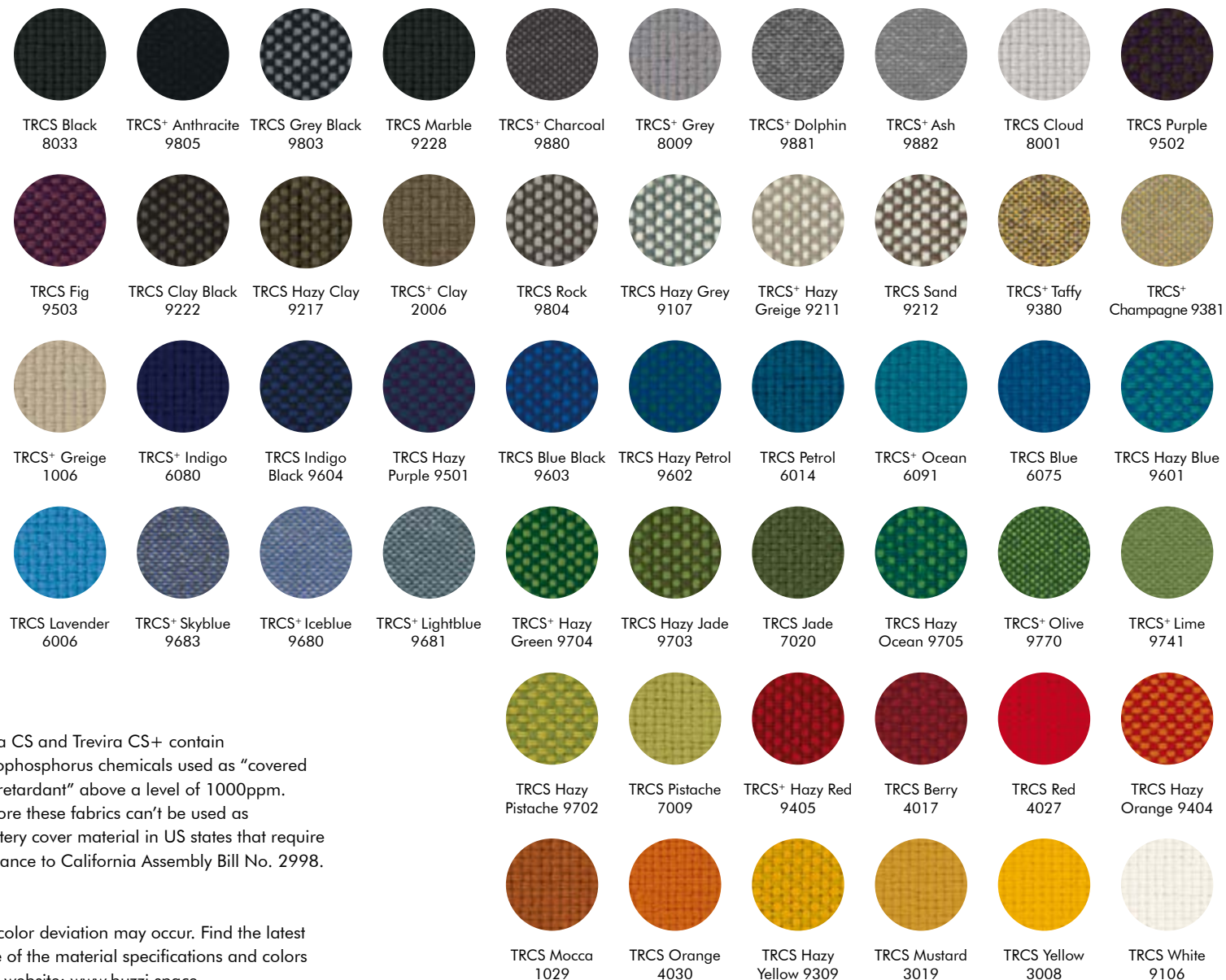

*Trevira CS and Trevira CS+ contain organophosphorus chemicals used as "covered flame retardant" above a level of 1000ppm. Therefore these fabrics can't be used as upholstery cover material in US states that require compliance to California Assembly Bill No. 2998.

Note color deviation may occur. Find the latest update of the material specifications and colors on our website: www.buzzi.space

Revive 1

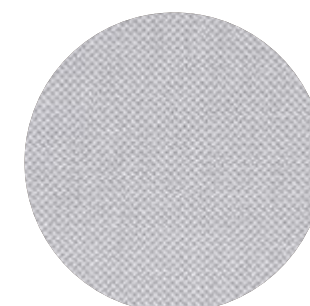

Revive 1 144

Composition 100% recycled polyester FR
Weight 430 g/lin.m
Width 140 cm | 55.11"
Abrasion resistance 60.000 Martindale rubs, EN ISO 12947
Flammability EN 1021-1/2 | DIN 4102 B1 | Önorm B1/Q1
 UNI 9175 11M | US Cal. Tech. Bull. 117*
 IMO A.652 (16)
Fastness to light Note 5-7, ISO 105-B02
Fastness to rubbing (ISO) dry 5, wet 4-5
Pilling Note 4-5, EN ISO 12945
Maintenance Vacuuming and dry cleaning.
 Washable at max. 60°C.
 Drip drying.

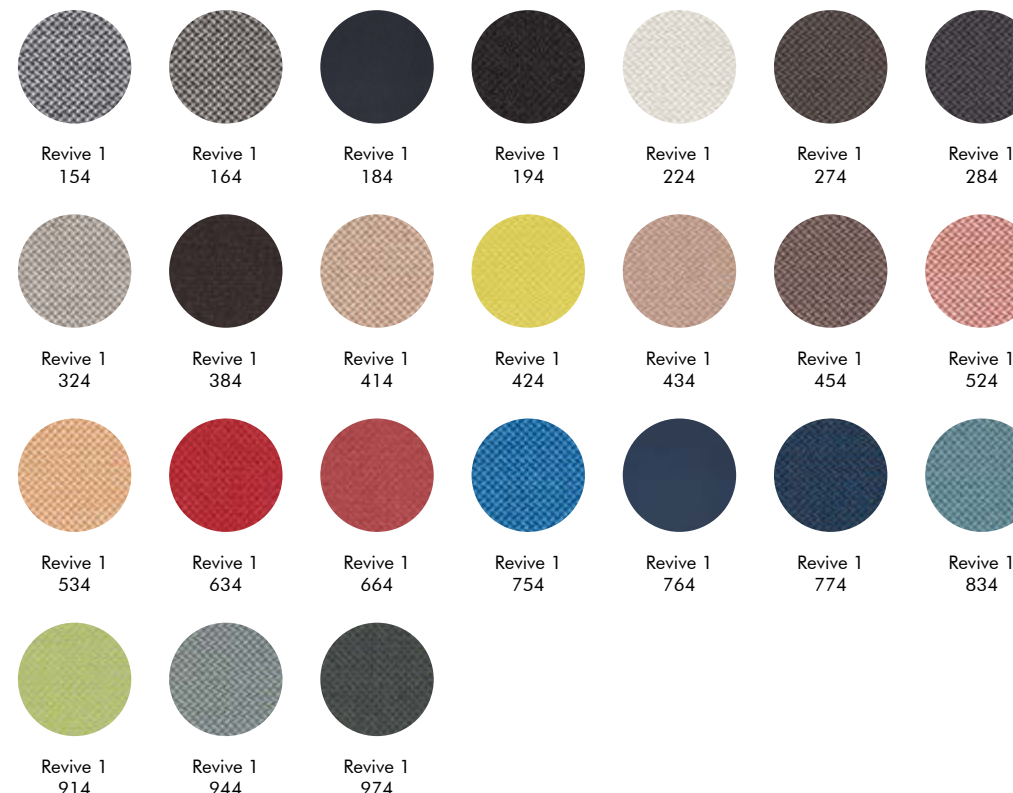

kvadrat

CAT A

FABRIC
TREVIRA CS+
TREVIRA CS
REVIVE 1

*Revive 1 contains organophosphorus chemicals used as "covered flame retardant" above a level of 1000ppm. Therefore this fabric can't be used as upholstery cover material in US states that require compliance to California Assembly Bill No. 2998.

Note color deviation may occur. Find the latest update of the material specifications and colors on our website: www.buzzi.space



Clara 2

kvadrat

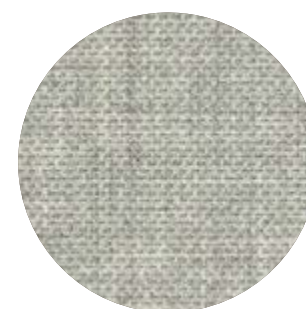

Clara 2
144

Composition 92% new wool, 8% nylon
Weight 400 g/lin.m
Width 138 cm | 54.33"
Abrasion resistance 80.000 Martindale rubs, EN ISO 12947
Flammability EN 1021-1/2 | BS 5852, ignition source 2-3 | DIN 4102 B2
 NF D 60 013 | UNI 9175 1IM | US Cal. Tech. Bull. 117, Sec. E
 NFPA 260 | IMO A.652(16)
Fastness to light Note 5-7, ISO 105-B02
Fastness to rubbing (ISO) dry 4-5, wet 4
Pilling Note 4, EN ISO 12945
Maintenance Vacuuming and dry cleaning

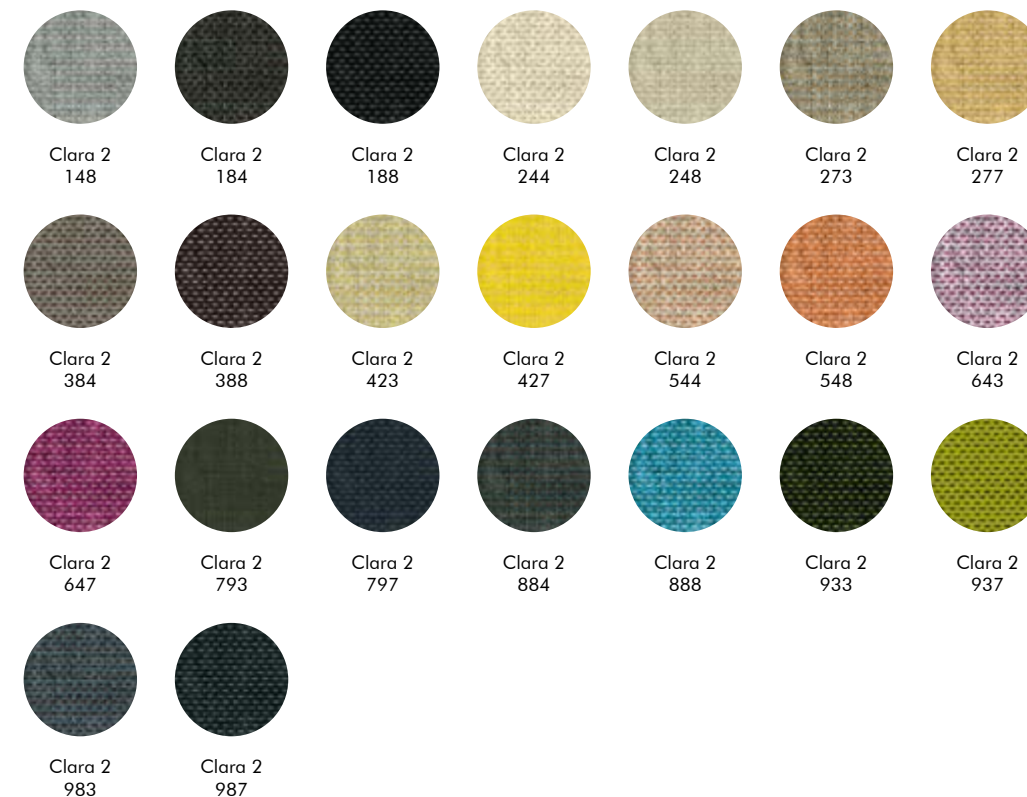

CAT B

CLARA 2
REMIX 3
VELVET

Note color deviation may occur.
Find the latest update of the material specifications and colors on our website:
www.buzzi.space

CAT B

CLARA 2
REMIX 3
VELVET

Remix 3



Remix 3
113

Composition 90% new wool, 10% nylon
Weight 415 g/lin.m
Width 138 cm | 54.33"
Abrasion resistance 100.000 Martindale rubs, EN ISO 12947
Flammability EN 1021-1/2 | BS 5852 part 1
 Önorm B1/Q1 | NF D 60 013 | UNI 9175, 11M
 AS/NZS 1530.3 | Cal. Tech. Bull. 117-2013
 NFPA 260 | IMO FTP Code 2010:Part 8
Fastness to light Note 5-7, ISO 105-B02
Fastness to rubbing (ISO) dry 4-5, wet 4
Pilling Note 4, EN ISO 12945
Maintenance Vacuuming and dry cleaning



kvadrat

CAT B

CLARA 2
REMIX 3
VELVET

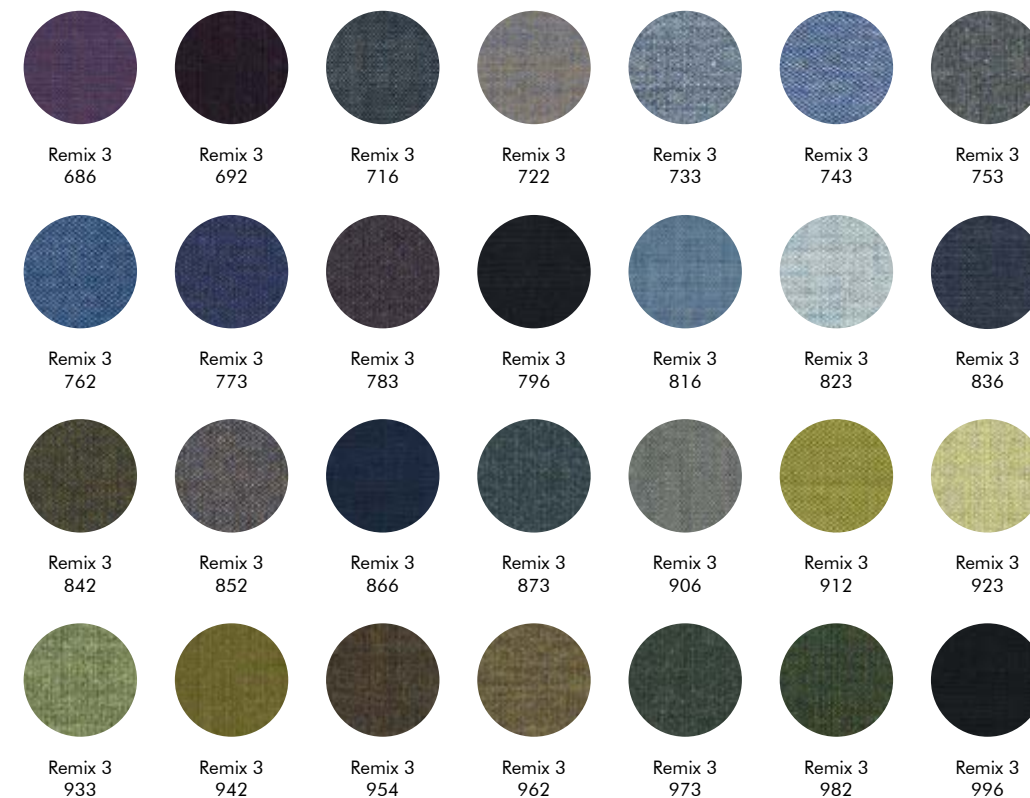

Note color deviation may occur.
Find the latest update of the material specifications and colors on our website: www.buzzi.space

CAT B

CLARA 2
REMIX 3
VELVET

Velvet



VE-Gold
401

Composition 100% PES
Weight 375 g/m² | 11.06 oz/yd²
Width 140 cm | 55.12"
Thickness 0,7mm | 0.0275"
Abrasion resistance >100.000 Martindale
Flammability USA: CAL TB 117
Fastness to light EU: 4-5
Fastness to rubbing EU: Wet 4 | Dry 4-5
Pilling EU: 4-5
Match Weight ±5% | Width ±2%
Maintenance Vacuum clean regularly. Don't wash. Don't remove the Velvet from the product. Treat spillages immediately. Professional dry clean or wipe clean with a pH neutral soap and a damp cloth.

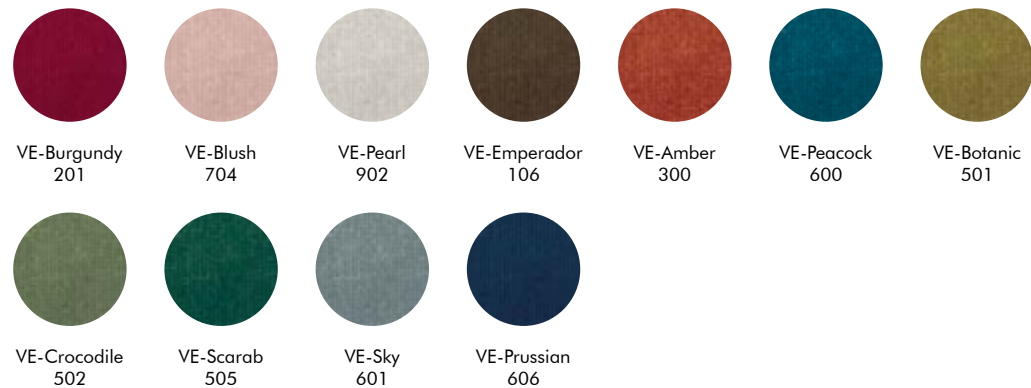

Note color deviation may occur.
Find the latest update of the material specifications and colors on our website:
www.buzzi.space

CAT C

HERO

Hero

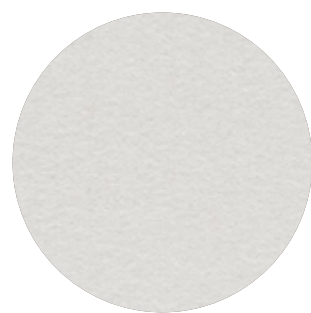

Hero 101

Composition 96% new wool, 4% nylon
Weight 580 g/lin.m
Width 140 cm | 55.11"
Abrasion resistance 45.000 Martindale rubs, EN ISO 12947
Flammability EN 1021-1/2 | DIN 4102 B2 | NF D 60 013
 UNI 9175 11M | US Cal. Bull. 117-2013 | NFPA 260
 IMO A.652 (16)
Fastness to light Note 5-6, ISO 105-B02
Fastness to rubbing (ISO) dry 4-5, wet 4-5
Pilling Note 3-4, EN ISO 12945
Maintenance Vacuuming and dry cleaning.
 Washable at max. 30°C, wool programme. Drip drying.
 Mount covers in slightly wet condition

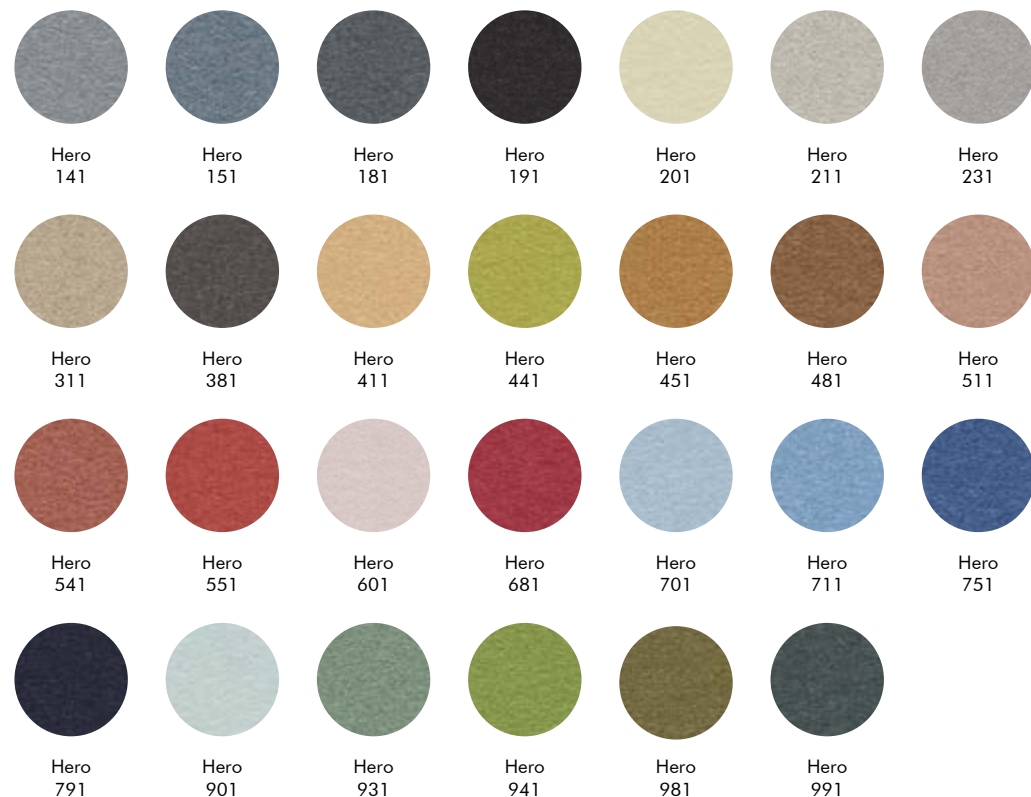

kvadrat

Tonus 4



Tonus 4 100

Composition 90% new wool, 10% Helanca
Weight 665 g/lin.m
Width 140 cm | 55.11"
Abrasion resistance 100.000 Martindale rubs, EN ISO 12947
Flammability EN 1021-1/2 | BS 5852 part 1 | DIN 4102 B2
 Önorm B1/Q1 | NF D 60 013 | UNI 9175 11M
 US Cal. Bull. 117-2013 | NFPA 260 | IMO A.652 (16)
Fastness to light Note 5-7, ISO 105-B02
Fastness to rubbing (ISO) dry 3-5, wet 3-5
Pilling Note 3, EN ISO 12945
Maintenance Vacuuming and dry cleaning



kvadrat

CAT D

TONUS 4



Note color deviation may occur.
 Find the latest update of the material specifications and colors on our website:
www.buzzi.space

CAT E

MEMORY 2

Memory 2



Memory 116

Composition 100% Trevira CS
Weight 700 g/lin.m
Width 150 cm | 59.05"
Abrasion resistance
 35.000 rubs acc. to the Martindale method, EN ISO 12947
Flammability EN 1021-1/2 | DIN 4102 B1 | Önorm B1/Q1
 NF D 60 013 | NF P 92 507 M1 | UNI 9175 11M
 UNI 9177 classe 1 | US Cal. Tech. Bull. 117*
 IMO A.652 (16)
Fastness to light Note 5-8, ISO 105-B02
Fastness to rubbing (ISO) dry 4-5, wet 4-5
Pilling Note 4, EN ISO 12945
Maintenance Vacuuming and dry cleaning.
 Washable at max. 60°C.
 Drip drying.

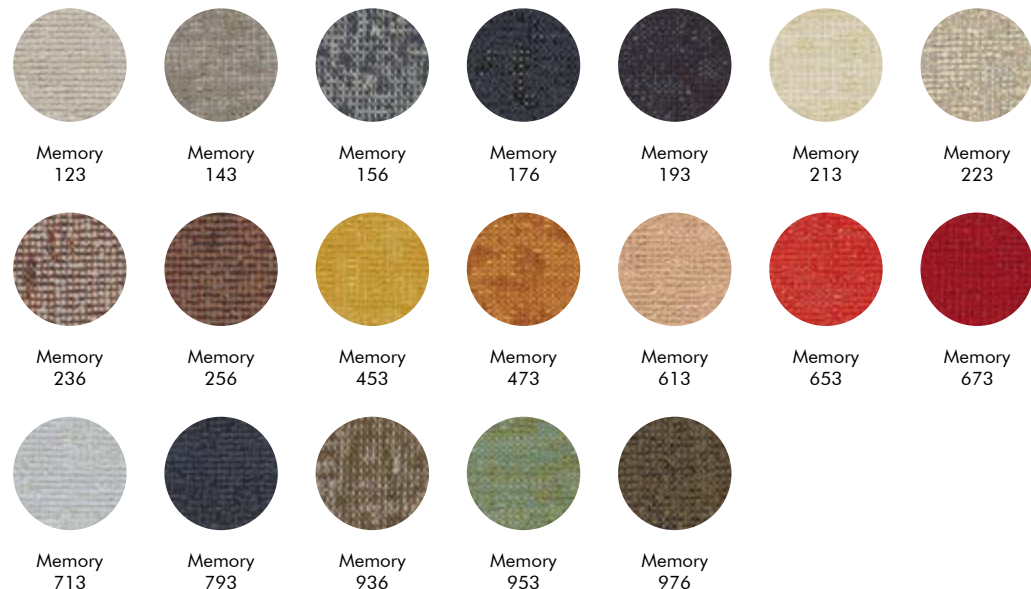

kvadrat

Vegetal



VG-Black 98



VG-Cognac 91

Raw material Scandinavian Bullhides
Thickness 1,2 - 1,4 mm | 0.047 - 0.055 inch
Surface Pure Aniline
Flammability EU: EN 1021.1 - BS 5852 PART 1 (cigarette)
 EN 1021.2 - BS 5852 PART 1 (match)
 USA: CAL TB 117
Fastness to light EU: 3 Blue Scale (72h exposition)
Fastness to rubbing EU: Wet: 20 cycles/3 | Dry: 50 cycles/3
 Sweat: 20 cycles/3
Strength Tear resistance: >20N or 10N/mm thickness
 Tensile: >20N/mm²
 Elongation: 40-70%
Match Normal life markings (scars, wrinkles, scratches) certify the authenticity of the leather. Dust with a soft cloth regularly. Don't expose to direct sunlight. Be careful with sharp objects. Spills should be blotted with a soft absorbent cloth. Don't rub. Never use detergents, shoe polish, alkalized products.

LEATHER

VEGETAL

* Memory 2 contains organophosphorus chemicals used as "covered flame retardant" above a level of 1000ppm. Therefore this fabric can't be used as upholstery cover material in US states that require compliance to California Assembly Bill No. 2998.

Note color deviation may occur. Find the latest update of the material specifications and colors on our website: www.buzzi.space

Note color deviation may occur. Find the latest update of the material specifications and colors on our website: www.buzzi.space

CURTAINS

FABRICS

370 **Curtain A**
370 Frost

371 - 372 **Curtain B**
371 Daybreak 2
372 Velvet

373 - 374 **Curtain C**
373 Dawn 2
374 Zulu 2

375 - 377 **Curtain D**
375 Drops
376 Mi Casa

378 - 379 **Curtain F**
378 Bonus
379 Drops Acoustic

CUR A

FROST

Frost

kvadrat

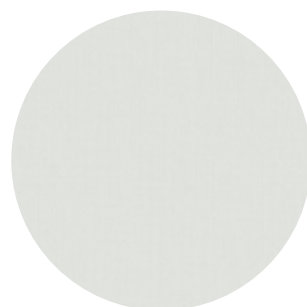

Frost 106



Composition 50% polyester FR, 50% polyester
Weight App. 150 g/lin.m
Flammability EN 13 773 class 1 | BS 5867 part 2 type B | DIN 4102 B1 | SN 198 898 5.2 | NF D 92 507 M1 | UNI 9177 classe 1 | NFPA 701 | AS/NZS 1530.3 | IMO A.471 (XII)
Fastness to light Note 5-7, ISO 105-B02
Maintenance Washable at max. 60°C. Drip drying. Ironing will be necessary

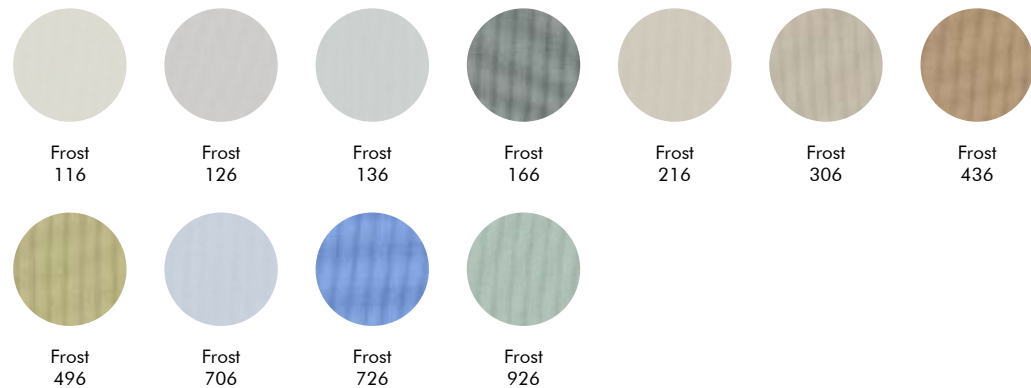

Daybreak 2

kvadrat

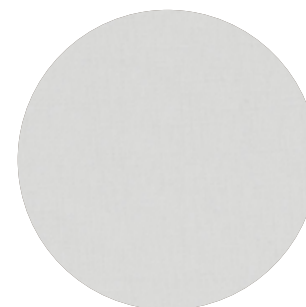

Daybreak 2 101



Composition 100% polyester FR
Weight App. 270 g/lin.m
Flammability EN 13 773 class 1 | BS 5867 part 2 type B | DIN 4102 B1 | SN 198 898 5.2 | NF D 92 507 M1 | UNI 9177 classe 1 | AS/NZS 1530.3 | IMO A.471 (XII)
Fastness to light Note 5-7, ISO 105-B02
Maintenance Washable at max. 60°C. Drip drying. Ironing will be necessary

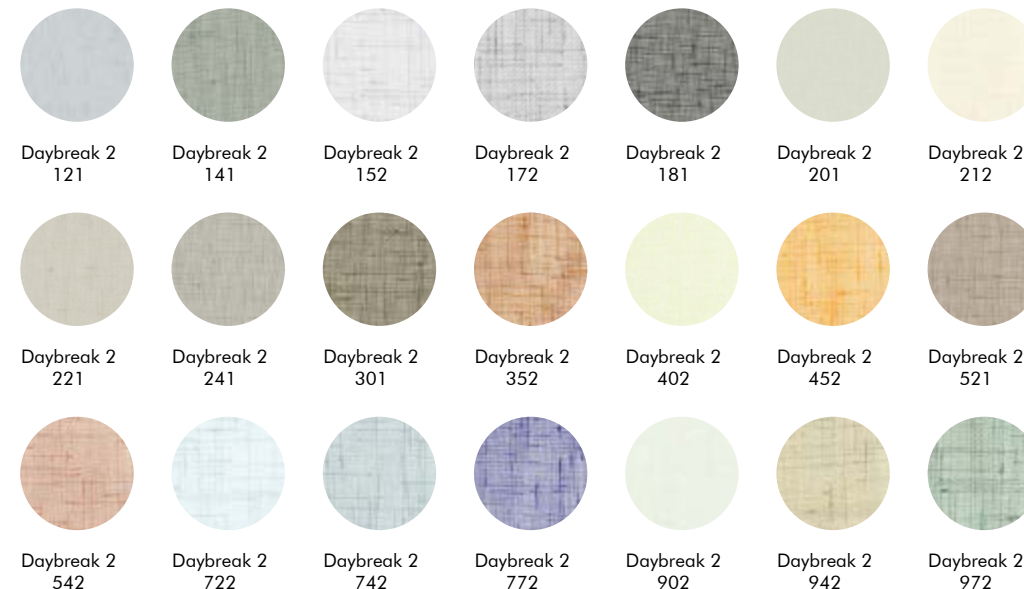

CUR B

DAYBREAK 2
VELVET

CUR B

DAYBREAK 2
VELVET

Velvet



VE-Gold
01

Composition 100% PES
Weight 375 g/m² | 11.06 oz/yd²
Width 140 cm | 55.12"
Thickness 0,7mm | 0.0275"
Abrasion resistance >100.000 Martindale
Flammability USA: CAL TB 117
Fastness to light EU: 4-5
Fastness to rubbing EU: Wet 4 | Dry 4-5
Pilling EU: 4-5
Match Weight ±5% | Width ±2%
Maintenance Washable at max. 40°C. Drip drying.

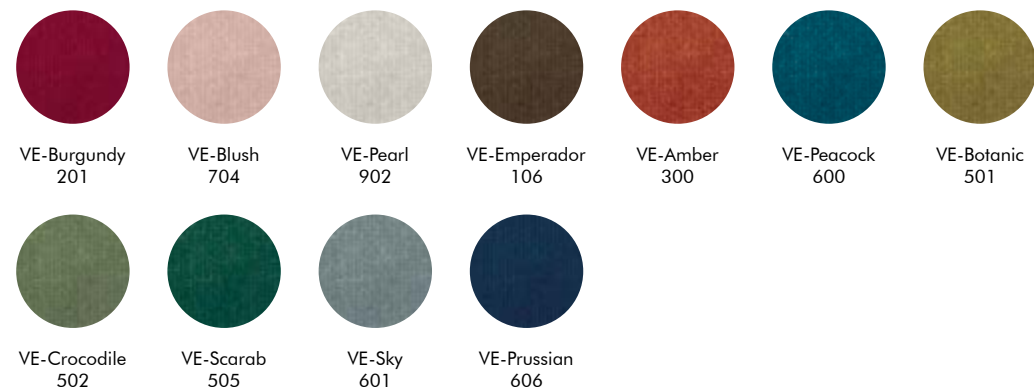

Dawn 2



Dawn 2
102

Composition 100% polyester FR
Weight App. 780 g/lin.m
Flammability EN 13 773 class 1 | EN 13501, B-s1, d0 | BS 5867 part 2 type B | DIN 4102 B1 | SN 198 898 5.2 | NF D 92 507 M1 | UNI 9177 classe 1
Fastness to light Note 5-7, ISO 105-B02
Maintenance Washable at max. 60°C. Half wash load. Drip drying. Ironing might be necessary when washed at 60°C.

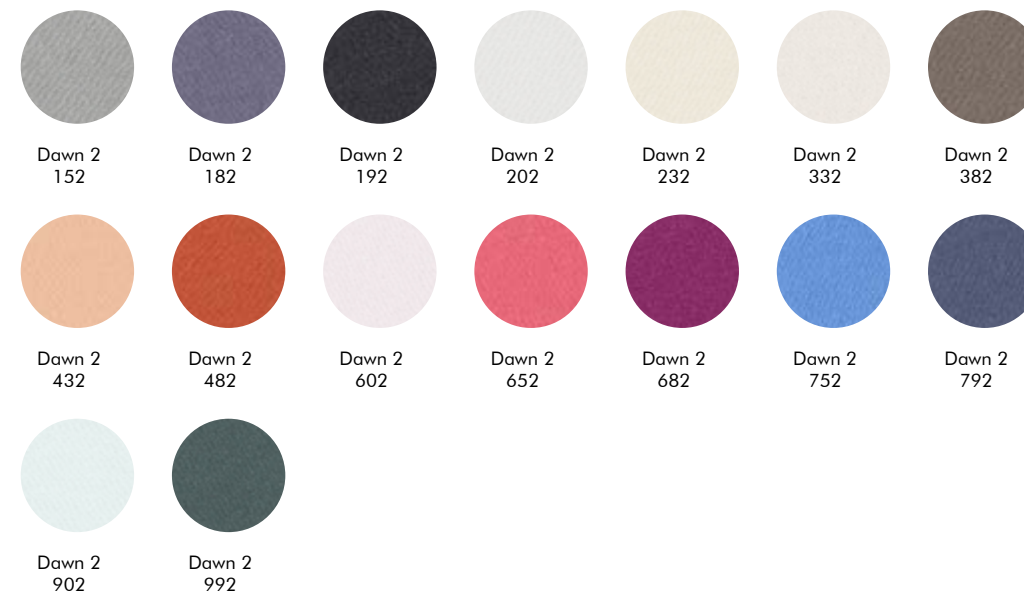

CUR C

DAWN 2
ZULU 2

CUR C

DAWN 2
ZULU 2

Zulu 2

kvadrat

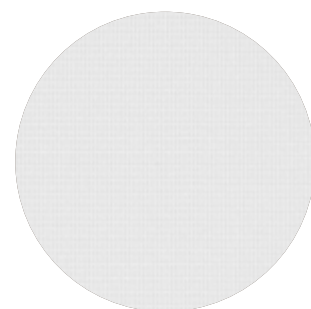

Zulu 2
104



Composition 100 % Trevira CS
Weight App. 300 g/lin.m
Flammability EN 13 773 class 1 | BS 5867 part 2 | DIN 4102 B1 | NF P 92 507 M1 | UNI 9177 classe 1 | IMO FTP Code 2010:Part 7
Fastness to light Note 7, ISO 105-B02
Maintenance Wash at 40°C. Dripdrying

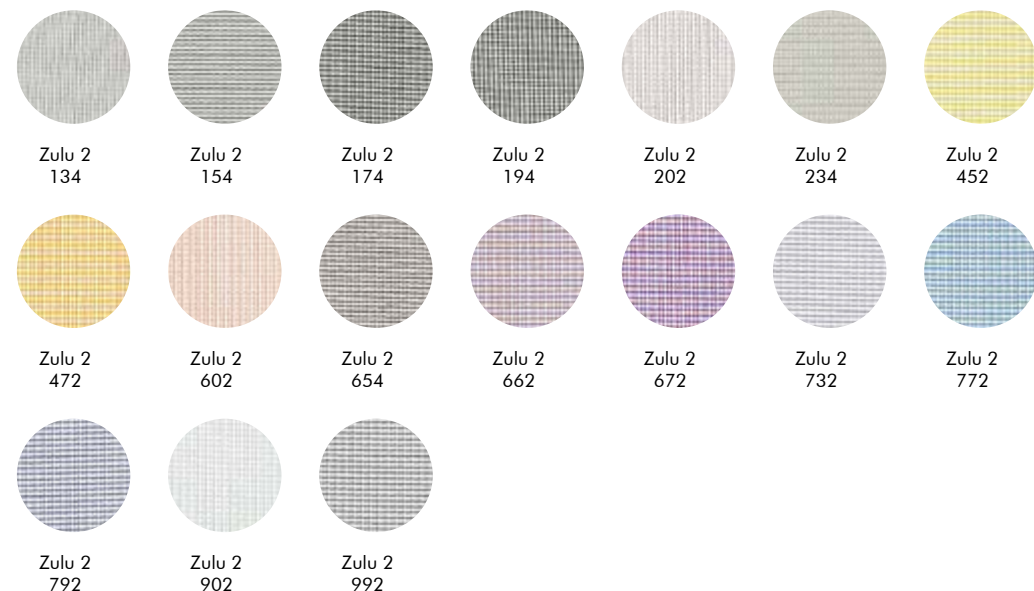

Drops

kvadrat

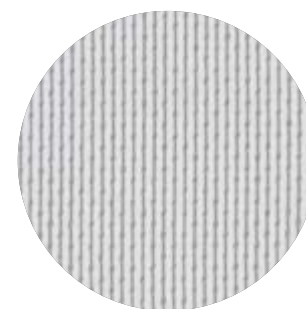

Drops
122



Composition 100 % Trevira CS
Weight App. 225 g/lin.m
Flammability EN 13 773 class 1 | BS 5867 part 2 type B | DIN 4102 B1 | NF D 92 507 M1 | UNI 9177 classe 1 | FAR 25.853 | IMO FTP Code 2010:Part 7
Fastness to light Note 6-7, ISO 105-B02
Maintenance Washable at max. 60°C. Dripdrying.

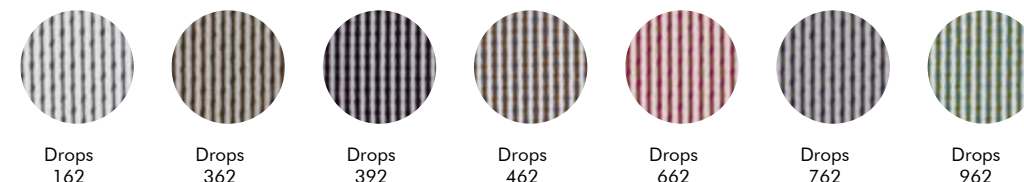

CUR D

DROPS
MI CASA

CUR D

DROPS
MI CASA

Mi Casa

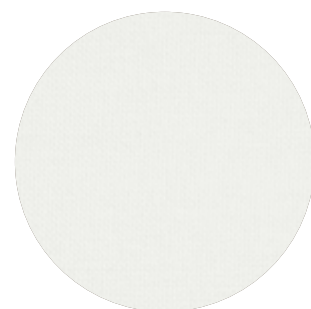

Mi Casa
111

Composition 100% Trevira CS
Weight App. 600 g/lin.m
Flammability EN 13 773 class 1 | BS 5867 part 2 type B | DIN 4102 B1
 | SN 198 898 5.2 | NF D 92 507 M1 | UNI 9177 classe 1
 | IMO FTP Code 2010:Part 7
Fastness to light Note 5-7, ISO 105-B02
Maintenance Washable at max. 60°C. Half wash load. Drip drying.
 Ironing might be necessary when washed at 60°C.



kvadrat

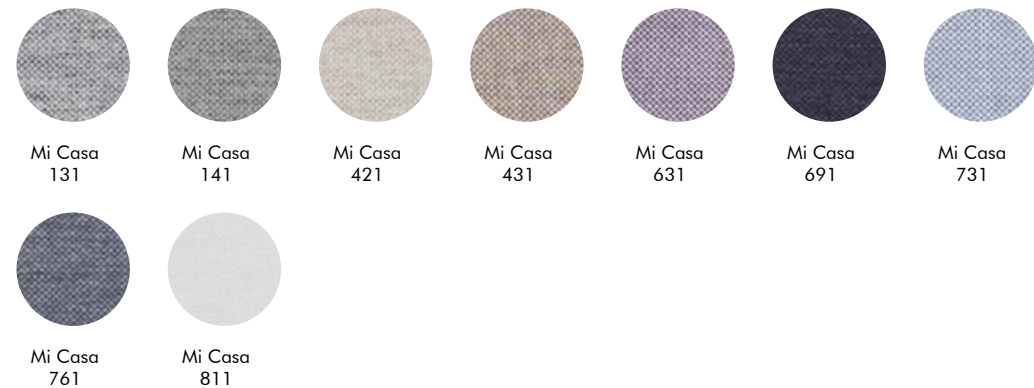

CUR F

BONUS
DROPS ACOUSTIC

Bonus

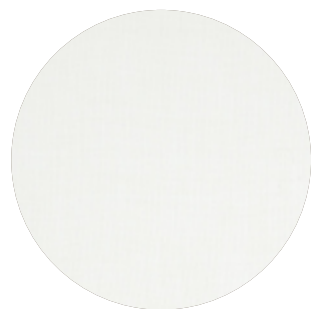

Bonus
1

Composition 100% wool
Weight 385 g/lin.m
Fastness to light 5 (ISO 1-8)
Maintenance Washable on hand wash cycle



Bonus 2 Bonus 6 Bonus 11 Bonus 23 Bonus 25

kvadrat

Drops Acoustic

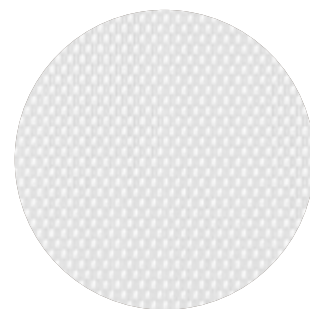

Drops Acoustic
107

Composition 100% Trevira CS
Weight App. 315 g/lin.m
Flammability BS 5867 part 2 type B | DIN 4102 B1 | EN 13773 Class 1
| IMO FTP Code 2010:Part 7 | NF P 92 507 M1 | SN 198 898
5.2 | UNI 9177 classe 1
Fastness to light Note 7 ISO 105-B02
Maintenance Washable at max. 60°C. Drip drying.

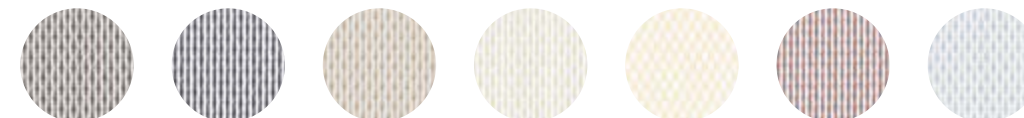

Drops Acoustic 177 Drops Acoustic 197 Drops Acoustic 227 Drops Acoustic 407 Drops Acoustic 427 Drops Acoustic 577 Drops Acoustic 727

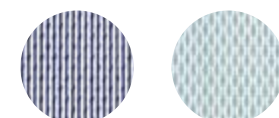

Drops Acoustic 797 Drops Acoustic 837

kvadrat

CUR F

BONUS
DROPS ACOUSTIC

SOLID MATERIALS

382 - 383 Application overview wood

384 - 387 Application overview metal

388 - 390 Wood

- 388 Ash Black Stained
- 388 Ash White Wash
- 388 Oak
- 388 Walnut
- 388 Ash Natural
- 388 Ash Walnut Stained
- 389 Cumaru
- 389 Iroko
- 389 Antwerp Oak
- 389 Ash Lacured
- 389 HPL
- 390 White Laminate

391 Metal

- 391 Powder Coated Metal
- 391 Uncoated Aluminum
- 391 Galvanized Metal

APPLICATION OVERVIEW WOOD

Solid Materials

- Not possible
- Possible

Product		Cumaru	Iroko	Antwerp Oak	Oak	Walnut	Ash Natural	Ash Walnut Stained	Ash Black Stained	Ash White Wash	Ash Lacquered	HPL	White Laminate	Melamine
BuzziBalance		<input type="radio"/>	<input type="radio"/>	<input type="radio"/>	<input type="radio"/>	<input type="radio"/>	<input checked="" type="radio"/>	<input type="radio"/>	<input type="radio"/>	<input type="radio"/>	<input type="radio"/>	<input type="radio"/>	<input type="radio"/>	<input type="radio"/>
BuzziBooth Single	Worktop	<input type="radio"/>	<input type="radio"/>	<input checked="" type="radio"/>	<input type="radio"/>	<input type="radio"/>	<input type="radio"/>	<input type="radio"/>	<input type="radio"/>	<input type="radio"/>	<input type="radio"/>	<input type="radio"/>	<input checked="" type="radio"/>	<input type="radio"/>
BuzziBooth Standing	Worktop	<input type="radio"/>	<input type="radio"/>	<input checked="" type="radio"/>	<input type="radio"/>	<input type="radio"/>	<input type="radio"/>	<input type="radio"/>	<input type="radio"/>	<input type="radio"/>	<input type="radio"/>	<input type="radio"/>	<input checked="" type="radio"/>	<input type="radio"/>
BuzziBooth Side by Side	Worktop	<input type="radio"/>	<input type="radio"/>	<input checked="" type="radio"/>	<input type="radio"/>	<input type="radio"/>	<input type="radio"/>	<input type="radio"/>	<input type="radio"/>	<input type="radio"/>	<input type="radio"/>	<input type="radio"/>	<input checked="" type="radio"/>	<input type="radio"/>
BuzziBreeze	Base	<input type="radio"/>	<input type="radio"/>	<input type="radio"/>	<input type="radio"/>	<input type="radio"/>	<input type="radio"/>	<input type="radio"/>	<input type="radio"/>	<input type="radio"/>	<input type="radio"/>	<input type="radio"/>	<input type="radio"/>	<input type="radio"/>
	Worktop & Seats	<input type="radio"/>	<input checked="" type="radio"/>	<input type="radio"/>	<input checked="" type="radio"/>	<input type="radio"/>	<input type="radio"/>	<input type="radio"/>	<input type="radio"/>	<input type="radio"/>	<input type="radio"/>	<input type="radio"/>	<input type="radio"/>	<input type="radio"/>
BuzziBracks	Worktop & Shelves	<input type="radio"/>	<input type="radio"/>	<input checked="" type="radio"/>	<input type="radio"/>	<input type="radio"/>	<input type="radio"/>	<input type="radio"/>	<input type="radio"/>	<input type="radio"/>	<input type="radio"/>	<input type="radio"/>	<input checked="" type="radio"/>	<input type="radio"/>
BuzziFloat		<input type="radio"/>	<input type="radio"/>	<input type="radio"/>	<input type="radio"/>	<input type="radio"/>	<input type="radio"/>	<input type="radio"/>	<input checked="" type="radio"/>	<input checked="" type="radio"/>	<input type="radio"/>	<input type="radio"/>	<input type="radio"/>	<input type="radio"/>
BuzziHood	Tablet	<input type="radio"/>	<input type="radio"/>	<input type="radio"/>	<input checked="" type="radio"/>	<input type="radio"/>	<input type="radio"/>	<input type="radio"/>	<input type="radio"/>	<input type="radio"/>	<input type="radio"/>	<input type="radio"/>	<input type="radio"/>	<input type="radio"/>
BuzziMilk		<input type="radio"/>	<input type="radio"/>	<input type="radio"/>	<input checked="" type="radio"/>	<input checked="" type="radio"/>	<input checked="" type="radio"/>	<input type="radio"/>	<input checked="" type="radio"/>	<input checked="" type="radio"/>	<input checked="" type="radio"/>	<input type="radio"/>	<input type="radio"/>	<input type="radio"/>
BuzziMilk Table		<input type="radio"/>	<input type="radio"/>	<input type="radio"/>	<input checked="" type="radio"/>	<input checked="" type="radio"/>	<input checked="" type="radio"/>	<input type="radio"/>	<input checked="" type="radio"/>	<input checked="" type="radio"/>	<input type="radio"/>	<input type="radio"/>	<input type="radio"/>	<input type="radio"/>
BuzziMirage	L	<input type="radio"/>	<input type="radio"/>	<input type="radio"/>	<input type="radio"/>	<input type="radio"/>	<input type="radio"/>	<input type="radio"/>	<input checked="" type="radio"/>	<input checked="" type="radio"/>	<input type="radio"/>	<input type="radio"/>	<input type="radio"/>	<input type="radio"/>
BuzziNordic ST100	ST101	<input type="radio"/>	<input type="radio"/>	<input type="radio"/>	<input checked="" type="radio"/>	<input checked="" type="radio"/>	<input checked="" type="radio"/>	<input type="radio"/>	<input checked="" type="radio"/>	<input checked="" type="radio"/>	<input checked="" type="radio"/>	<input type="radio"/>	<input type="radio"/>	<input type="radio"/>
	ST101 Ottoman	<input type="radio"/>	<input type="radio"/>	<input type="radio"/>	<input checked="" type="radio"/>	<input checked="" type="radio"/>	<input checked="" type="radio"/>	<input type="radio"/>	<input checked="" type="radio"/>	<input checked="" type="radio"/>	<input type="radio"/>	<input type="radio"/>	<input type="radio"/>	<input type="radio"/>
	ST101 Foodstool	<input type="radio"/>	<input type="radio"/>	<input type="radio"/>	<input checked="" type="radio"/>	<input checked="" type="radio"/>	<input checked="" type="radio"/>	<input type="radio"/>	<input checked="" type="radio"/>	<input checked="" type="radio"/>	<input type="radio"/>	<input type="radio"/>	<input type="radio"/>	<input type="radio"/>
	ST102	<input type="radio"/>	<input type="radio"/>	<input type="radio"/>	<input checked="" type="radio"/>	<input checked="" type="radio"/>	<input checked="" type="radio"/>	<input type="radio"/>	<input checked="" type="radio"/>	<input checked="" type="radio"/>	<input checked="" type="radio"/>	<input type="radio"/>	<input type="radio"/>	<input type="radio"/>
	ST103	<input type="radio"/>	<input type="radio"/>	<input type="radio"/>	<input checked="" type="radio"/>	<input checked="" type="radio"/>	<input checked="" type="radio"/>	<input type="radio"/>	<input checked="" type="radio"/>	<input checked="" type="radio"/>	<input checked="" type="radio"/>	<input type="radio"/>	<input type="radio"/>	<input type="radio"/>
	ST111	<input type="radio"/>	<input type="radio"/>	<input type="radio"/>	<input checked="" type="radio"/>	<input checked="" type="radio"/>	<input checked="" type="radio"/>	<input type="radio"/>	<input checked="" type="radio"/>	<input checked="" type="radio"/>	<input type="radio"/>	<input type="radio"/>	<input type="radio"/>	<input type="radio"/>
	ST111 Ottoman	<input type="radio"/>	<input type="radio"/>	<input type="radio"/>	<input checked="" type="radio"/>	<input checked="" type="radio"/>	<input checked="" type="radio"/>	<input type="radio"/>	<input checked="" type="radio"/>	<input checked="" type="radio"/>	<input type="radio"/>	<input type="radio"/>	<input type="radio"/>	<input type="radio"/>
BuzziNordic ST400		<input type="radio"/>	<input type="radio"/>	<input type="radio"/>	<input type="radio"/>	<input checked="" type="radio"/>	<input type="radio"/>	<input type="radio"/>	<input checked="" type="radio"/>	<input type="radio"/>	<input type="radio"/>	<input type="radio"/>	<input type="radio"/>	<input type="radio"/>
BuzziNordic ST900		<input checked="" type="radio"/>	<input type="radio"/>	<input type="radio"/>	<input type="radio"/>	<input type="radio"/>	<input type="radio"/>	<input type="radio"/>	<input type="radio"/>	<input type="radio"/>	<input type="radio"/>	<input type="radio"/>	<input type="radio"/>	<input type="radio"/>
BuzziPicNic		<input type="radio"/>	<input type="radio"/>	<input type="radio"/>	<input checked="" type="radio"/>	<input type="radio"/>	<input checked="" type="radio"/>	<input checked="" type="radio"/>	<input checked="" type="radio"/>	<input checked="" type="radio"/>	<input checked="" type="radio"/>	<input checked="" type="radio"/>	<input type="radio"/>	<input type="radio"/>
BuzziPicNic Round		<input type="radio"/>	<input type="radio"/>	<input type="radio"/>	<input checked="" type="radio"/>	<input type="radio"/>	<input checked="" type="radio"/>	<input checked="" type="radio"/>	<input checked="" type="radio"/>	<input checked="" type="radio"/>	<input type="radio"/>	<input type="radio"/>	<input type="radio"/>	<input type="radio"/>
BuzziPlank		<input type="radio"/>	<input type="radio"/>	<input type="radio"/>	<input type="radio"/>	<input type="radio"/>	<input checked="" type="radio"/>	<input checked="" type="radio"/>	<input checked="" type="radio"/>	<input checked="" type="radio"/>	<input type="radio"/>	<input type="radio"/>	<input type="radio"/>	<input type="radio"/>
BuzziRing	Worktop	<input type="radio"/>	<input type="radio"/>	<input type="radio"/>	<input type="radio"/>	<input type="radio"/>	<input checked="" type="radio"/>	<input checked="" type="radio"/>	<input checked="" type="radio"/>	<input checked="" type="radio"/>	<input type="radio"/>	<input type="radio"/>	<input type="radio"/>	<input checked="" type="radio"/>
BuzziTemp	Worktop	<input type="radio"/>	<input type="radio"/>	<input checked="" type="radio"/>	<input type="radio"/>	<input type="radio"/>	<input type="radio"/>	<input type="radio"/>	<input type="radio"/>	<input type="radio"/>	<input type="radio"/>	<input type="radio"/>	<input type="radio"/>	<input type="radio"/>
BuzziVille	Worktops	<input type="radio"/>	<input type="radio"/>	<input checked="" type="radio"/>	<input type="radio"/>	<input type="radio"/>	<input type="radio"/>	<input type="radio"/>	<input type="radio"/>	<input type="radio"/>	<input type="radio"/>	<input type="radio"/>	<input checked="" type="radio"/>	<input type="radio"/>
	Tablet	<input type="radio"/>	<input type="radio"/>	<input checked="" type="radio"/>	<input type="radio"/>	<input type="radio"/>	<input type="radio"/>	<input type="radio"/>	<input type="radio"/>	<input type="radio"/>	<input type="radio"/>	<input type="radio"/>	<input checked="" type="radio"/>	<input type="radio"/>

APPLICATION OVERVIEW METAL

Solid Materials

- Not possible
- Possible

Product		Powder Coated Metal													Galvanized Steel	Uncoated Aluminum	Brass	
		Black RAL 9005	Alu RAL 9006	White RAL 9010	Umbr Grey RAL 7022	Fluo Orange RAL 2005	Fluo Yellow RAL 1016	Beige Red RAL 3012	Gold	Signal grey RAL 7004	Black Green RAL 6012	Pastel Blue RAL 5024	Pastel Green RAL 6019	Light Green RAL 6027				
BuzziBell	Frame	<input checked="" type="radio"/>	<input type="radio"/>	<input checked="" type="radio"/>	<input type="radio"/>	<input type="radio"/>	<input checked="" type="radio"/>	<input type="radio"/>	<input type="radio"/>	<input type="radio"/>	<input type="radio"/>	<input type="radio"/>	<input type="radio"/>	<input type="radio"/>	<input type="radio"/>	<input type="radio"/>	<input type="radio"/>	<input type="radio"/>
BuzziBlinds	Baseplate	<input checked="" type="radio"/>	<input type="radio"/>	<input checked="" type="radio"/>	<input type="radio"/>	<input type="radio"/>	<input type="radio"/>	<input type="radio"/>	<input type="radio"/>	<input type="radio"/>	<input type="radio"/>	<input type="radio"/>	<input type="radio"/>	<input type="radio"/>	<input type="radio"/>	<input type="radio"/>	<input type="radio"/>	<input type="radio"/>
BuzziBreeze	Base	<input checked="" type="radio"/>	<input type="radio"/>	<input checked="" type="radio"/>	<input type="radio"/>	<input type="radio"/>	<input type="radio"/>	<input type="radio"/>	<input type="radio"/>	<input type="radio"/>	<input type="radio"/>	<input type="radio"/>	<input type="radio"/>	<input type="radio"/>	<input type="radio"/>	<input type="radio"/>	<input type="radio"/>	<input type="radio"/>
	Worktop & Seats	<input checked="" type="radio"/>	<input type="radio"/>	<input checked="" type="radio"/>	<input type="radio"/>	<input type="radio"/>	<input type="radio"/>	<input type="radio"/>	<input type="radio"/>	<input type="radio"/>	<input type="radio"/>	<input type="radio"/>	<input type="radio"/>	<input type="radio"/>	<input type="radio"/>	<input type="radio"/>	<input type="radio"/>	<input type="radio"/>
BuzziBracks	Frames	<input checked="" type="radio"/>	<input type="radio"/>	<input type="radio"/>	<input type="radio"/>	<input type="radio"/>	<input type="radio"/>	<input checked="" type="radio"/>	<input type="radio"/>	<input checked="" type="radio"/>	<input checked="" type="radio"/>	<input checked="" type="radio"/>	<input checked="" type="radio"/>	<input checked="" type="radio"/>	<input type="radio"/>	<input type="radio"/>	<input type="radio"/>	<input type="radio"/>
BuzziCactus	Baseplate	<input checked="" type="radio"/>	<input checked="" type="radio"/>	<input type="radio"/>	<input type="radio"/>	<input type="radio"/>	<input type="radio"/>	<input type="radio"/>	<input type="radio"/>	<input type="radio"/>	<input type="radio"/>	<input type="radio"/>	<input type="radio"/>	<input type="radio"/>	<input type="radio"/>	<input type="radio"/>	<input type="radio"/>	<input type="radio"/>
BuzziChandelier	Frame	<input checked="" type="radio"/>	<input type="radio"/>	<input type="radio"/>	<input type="radio"/>	<input type="radio"/>	<input type="radio"/>	<input type="radio"/>	<input type="radio"/>	<input type="radio"/>	<input type="radio"/>	<input type="radio"/>	<input type="radio"/>	<input type="radio"/>	<input type="radio"/>	<input type="radio"/>	<input type="radio"/>	<input type="radio"/>
BuzziFix		<input checked="" type="radio"/>	<input checked="" type="radio"/>	<input checked="" type="radio"/>	<input type="radio"/>	<input type="radio"/>	<input type="radio"/>	<input type="radio"/>	<input type="radio"/>	<input type="radio"/>	<input type="radio"/>	<input type="radio"/>	<input type="radio"/>	<input type="radio"/>	<input type="radio"/>	<input type="radio"/>	<input type="radio"/>	<input type="radio"/>
BuzziFalls	Profile	<input checked="" type="radio"/>	<input type="radio"/>	<input checked="" type="radio"/>	<input type="radio"/>	<input type="radio"/>	<input type="radio"/>	<input type="radio"/>	<input type="radio"/>	<input type="radio"/>	<input type="radio"/>	<input type="radio"/>	<input type="radio"/>	<input type="radio"/>	<input type="radio"/>	<input type="radio"/>	<input type="radio"/>	<input type="radio"/>
BuzziFalls Standing	Profile	<input checked="" type="radio"/>	<input type="radio"/>	<input type="radio"/>	<input type="radio"/>	<input type="radio"/>	<input type="radio"/>	<input type="radio"/>	<input type="radio"/>	<input type="radio"/>	<input type="radio"/>	<input type="radio"/>	<input type="radio"/>	<input type="radio"/>	<input type="radio"/>	<input type="radio"/>	<input type="radio"/>	<input type="radio"/>
BuzziFree	Baseplate	<input checked="" type="radio"/>	<input checked="" type="radio"/>	<input type="radio"/>	<input type="radio"/>	<input type="radio"/>	<input type="radio"/>	<input type="radio"/>	<input type="radio"/>	<input type="radio"/>	<input type="radio"/>	<input type="radio"/>	<input type="radio"/>	<input type="radio"/>	<input type="radio"/>	<input type="radio"/>	<input type="radio"/>	<input type="radio"/>
BuzziFrio	Baseplate	<input checked="" type="radio"/>	<input checked="" type="radio"/>	<input type="radio"/>	<input type="radio"/>	<input type="radio"/>	<input type="radio"/>	<input type="radio"/>	<input type="radio"/>	<input type="radio"/>	<input type="radio"/>	<input type="radio"/>	<input type="radio"/>	<input type="radio"/>	<input type="radio"/>	<input type="radio"/>	<input type="radio"/>	<input type="radio"/>
BuzziFrontDesk	Fix	<input checked="" type="radio"/>	<input checked="" type="radio"/>	<input type="radio"/>	<input type="radio"/>	<input type="radio"/>	<input type="radio"/>	<input type="radio"/>	<input type="radio"/>	<input type="radio"/>	<input type="radio"/>	<input type="radio"/>	<input type="radio"/>	<input type="radio"/>	<input type="radio"/>	<input type="radio"/>	<input type="radio"/>	<input type="radio"/>
BuzziHat	Shade & Ring	<input checked="" type="radio"/>	<input type="radio"/>	<input checked="" type="radio"/>	<input type="radio"/>	<input type="radio"/>	<input type="radio"/>	<input checked="" type="radio"/>	<input checked="" type="radio"/>	<input type="radio"/>	<input type="radio"/>	<input type="radio"/>	<input type="radio"/>	<input type="radio"/>	<input type="radio"/>	<input type="radio"/>	<input type="radio"/>	<input type="radio"/>
BuzziHive	Frame	<input type="radio"/>	<input type="radio"/>	<input type="radio"/>	<input checked="" type="radio"/>	<input type="radio"/>	<input type="radio"/>	<input type="radio"/>	<input type="radio"/>	<input type="radio"/>	<input type="radio"/>	<input type="radio"/>	<input type="radio"/>	<input type="radio"/>	<input type="radio"/>	<input type="radio"/>	<input type="radio"/>	<input type="radio"/>
BuzziHood	Tablet	<input checked="" type="radio"/>	<input type="radio"/>	<input checked="" type="radio"/>	<input type="radio"/>	<input type="radio"/>	<input type="radio"/>	<input type="radio"/>	<input type="radio"/>	<input type="radio"/>	<input type="radio"/>	<input type="radio"/>	<input type="radio"/>	<input type="radio"/>	<input type="radio"/>	<input type="radio"/>	<input type="radio"/>	<input type="radio"/>
BuzziHub Table		<input checked="" type="radio"/>	<input type="radio"/>	<input checked="" type="radio"/>	<input type="radio"/>	<input type="radio"/>	<input type="radio"/>	<input type="radio"/>	<input type="radio"/>	<input type="radio"/>	<input type="radio"/>	<input type="radio"/>	<input type="radio"/>	<input type="radio"/>	<input type="radio"/>	<input type="radio"/>	<input type="radio"/>	<input type="radio"/>
BuzziJet	Frame	<input type="radio"/>	<input type="radio"/>	<input checked="" type="radio"/>	<input type="radio"/>	<input type="radio"/>	<input type="radio"/>	<input type="radio"/>	<input type="radio"/>	<input type="radio"/>	<input type="radio"/>	<input type="radio"/>	<input type="radio"/>	<input type="radio"/>	<input type="radio"/>	<input type="radio"/>	<input type="radio"/>	<input type="radio"/>
BuzziJungle		<input type="radio"/>	<input type="radio"/>	<input type="radio"/>	<input type="radio"/>	<input type="radio"/>	<input checked="" type="radio"/>	<input type="radio"/>	<input type="radio"/>	<input type="radio"/>	<input type="radio"/>	<input type="radio"/>	<input type="radio"/>	<input type="radio"/>	<input type="radio"/>	<input type="radio"/>	<input type="radio"/>	<input type="radio"/>
BuzziLight Mono	Frame	<input checked="" type="radio"/>	<input type="radio"/>	<input type="radio"/>	<input type="radio"/>	<input type="radio"/>	<input type="radio"/>	<input type="radio"/>	<input type="radio"/>	<input type="radio"/>	<input type="radio"/>	<input type="radio"/>	<input type="radio"/>	<input type="radio"/>	<input type="radio"/>	<input type="radio"/>	<input type="radio"/>	<input type="radio"/>
BuzziMe	Tablet	<input type="radio"/>	<input type="radio"/>	<input type="radio"/>	<input checked="" type="radio"/>	<input type="radio"/>	<input type="radio"/>	<input type="radio"/>	<input type="radio"/>	<input type="radio"/>	<input type="radio"/>	<input type="radio"/>	<input type="radio"/>	<input type="radio"/>	<input type="radio"/>	<input type="radio"/>	<input type="radio"/>	<input type="radio"/>
	Foot	<input type="radio"/>	<input type="radio"/>	<input type="radio"/>	<input checked="" type="radio"/>	<input type="radio"/>	<input type="radio"/>	<input type="radio"/>	<input type="radio"/>	<input type="radio"/>	<input type="radio"/>	<input type="radio"/>	<input type="radio"/>	<input type="radio"/>	<input type="radio"/>	<input type="radio"/>	<input type="radio"/>	<input type="radio"/>
BuzziMirage	M	<input checked="" type="radio"/>	<input type="radio"/>	<input type="radio"/>	<input type="radio"/>	<input type="radio"/>	<input type="radio"/>	<input checked="" type="radio"/>	<input type="radio"/>	<input checked="" type="radio"/>	<input checked="" type="radio"/>	<input type="radio"/>	<input type="radio"/>	<input type="radio"/>	<input type="radio"/>	<input type="radio"/>	<input type="radio"/>	<input type="radio"/>
BuzziMood	Frame	<input checked="" type="radio"/>	<input type="radio"/>	<input type="radio"/>	<input type="radio"/>	<input type="radio"/>	<input checked="" type="radio"/>	<input type="radio"/>	<input type="radio"/>	<input type="radio"/>	<input type="radio"/>	<input type="radio"/>	<input type="radio"/>	<input type="radio"/>	<input type="radio"/>	<input type="radio"/>	<input type="radio"/>	<input type="radio"/>
BuzziNordic ST400	Connection part	<input type="radio"/>	<input type="radio"/>	<input type="radio"/>	<input type="radio"/>	<input type="radio"/>	<input type="radio"/>	<input type="radio"/>	<input type="radio"/>	<input type="radio"/>	<input type="radio"/>	<input type="radio"/>	<input type="radio"/>	<input type="radio"/>	<input type="radio"/>	<input type="radio"/>	<input type="radio"/>	<input checked="" type="radio"/>
BuzziPlant	Baseplate	<input checked="" type="radio"/>	<input checked="" type="radio"/>	<input type="radio"/>	<input type="radio"/>	<input type="radio"/>	<input type="radio"/>	<input type="radio"/>	<input type="radio"/>	<input type="radio"/>	<input type="radio"/>	<input type="radio"/>	<input type="radio"/>	<input type="radio"/>	<input type="radio"/>	<input type="radio"/>	<input type="radio"/>	<input type="radio"/>
BuzziProp	Frame	<input checked="" type="radio"/>	<input type="radio"/>	<input type="radio"/>	<input type="radio"/>	<input type="radio"/>	<input type="radio"/>	<input type="radio"/>	<input type="radio"/>	<input type="radio"/>	<input type="radio"/>	<input type="radio"/>	<input type="radio"/>	<input type="radio"/>	<input type="radio"/>	<input type="radio"/>	<input type="radio"/>	<input type="radio"/>
BuzziRing	xxx	<input checked="" type="radio"/>	<input type="radio"/>	<input type="radio"/>	<input type="radio"/>	<input type="radio"/>	<input type="radio"/>	<input type="radio"/>	<input type="radio"/>	<input type="radio"/>	<input type="radio"/>	<input type="radio"/>	<input type="radio"/>	<input type="radio"/>	<input type="radio"/>	<input type="radio"/>	<input type="radio"/>	<input type="radio"/>
BuzziScreen	Foot	<input checked="" type="radio"/>	<input checked="" type="radio"/>	<input type="radio"/>	<input type="radio"/>	<input type="radio"/>	<input type="radio"/>	<input type="radio"/>	<input type="radio"/>	<input type="radio"/>	<input type="radio"/>	<input type="radio"/>	<input type="radio"/>	<input type="radio"/>	<input type="radio"/>	<input type="radio"/>	<input type="radio"/>	<input type="radio"/>

APPLICATION OVERVIEW METAL

Solid Materials

- Not possible
- Possible

Product		Powder Coated Metal													Galvanized Steel	Uncoated Aluminum	Brass	
		Black RAL 9005	Alu RAL 9006	White RAL 9010	Umbr Grey RAL 7022	Fluo Orange RAL 2005	Fluo Yellow RAL 1016	Beige Red RAL 3012	Gold	Signal grey RAL 7004	Black Green RAL 6012	Pastel Blue RAL 5024	Pastel Green RAL 6019	Light Green RAL 6027				
BuzziShade Pendant	Frame	<input checked="" type="radio"/>	<input type="radio"/>	<input checked="" type="radio"/>	<input type="radio"/>	<input checked="" type="radio"/>	<input type="radio"/>	<input type="radio"/>	<input type="radio"/>	<input type="radio"/>	<input type="radio"/>	<input type="radio"/>	<input type="radio"/>	<input type="radio"/>	<input type="radio"/>	<input type="radio"/>	<input checked="" type="radio"/>	<input type="radio"/>
BuzziShade Standing	Frame	<input checked="" type="radio"/>	<input type="radio"/>	<input checked="" type="radio"/>	<input type="radio"/>	<input type="radio"/>	<input type="radio"/>	<input type="radio"/>	<input type="radio"/>	<input type="radio"/>	<input type="radio"/>	<input type="radio"/>	<input type="radio"/>	<input type="radio"/>	<input type="radio"/>	<input type="radio"/>	<input type="radio"/>	<input type="radio"/>
BuzziShed	Frame	<input type="radio"/>	<input type="radio"/>	<input type="radio"/>	<input type="radio"/>	<input type="radio"/>	<input type="radio"/>	<input type="radio"/>	<input type="radio"/>	<input type="radio"/>	<input type="radio"/>	<input type="radio"/>	<input type="radio"/>	<input type="radio"/>	<input type="radio"/>	<input checked="" type="radio"/>	<input type="radio"/>	<input type="radio"/>
BuzziSpark	Frame	<input checked="" type="radio"/>	<input type="radio"/>	<input type="radio"/>	<input type="radio"/>	<input type="radio"/>	<input type="radio"/>	<input type="radio"/>	<input type="radio"/>	<input type="radio"/>	<input type="radio"/>	<input type="radio"/>	<input type="radio"/>	<input type="radio"/>	<input type="radio"/>	<input type="radio"/>	<input type="radio"/>	<input type="radio"/>
BuzziTemp	Frame	<input type="radio"/>	<input type="radio"/>	<input type="radio"/>	<input checked="" type="radio"/>	<input type="radio"/>	<input type="radio"/>	<input type="radio"/>	<input type="radio"/>	<input type="radio"/>	<input type="radio"/>	<input type="radio"/>	<input type="radio"/>	<input type="radio"/>	<input type="radio"/>	<input type="radio"/>	<input type="radio"/>	<input type="radio"/>
BuzziTotem	Baseplate	<input checked="" type="radio"/>	<input type="radio"/>	<input checked="" type="radio"/>	<input type="radio"/>	<input type="radio"/>	<input type="radio"/>	<input type="radio"/>	<input type="radio"/>	<input type="radio"/>	<input type="radio"/>	<input type="radio"/>	<input type="radio"/>	<input type="radio"/>	<input type="radio"/>	<input type="radio"/>	<input type="radio"/>	<input type="radio"/>
BuzziTripl Desk		<input type="radio"/>	<input type="radio"/>	<input checked="" type="radio"/>	<input type="radio"/>	<input type="radio"/>	<input type="radio"/>	<input type="radio"/>	<input type="radio"/>	<input type="radio"/>	<input type="radio"/>	<input type="radio"/>	<input type="radio"/>	<input type="radio"/>	<input type="radio"/>	<input type="radio"/>	<input type="radio"/>	<input type="radio"/>
BuzziTripl Desk Split		<input type="radio"/>	<input type="radio"/>	<input checked="" type="radio"/>	<input type="radio"/>	<input type="radio"/>	<input type="radio"/>	<input type="radio"/>	<input type="radio"/>	<input type="radio"/>	<input type="radio"/>	<input type="radio"/>	<input type="radio"/>	<input type="radio"/>	<input type="radio"/>	<input type="radio"/>	<input type="radio"/>	<input type="radio"/>
BuzziTripl Wrap Desk		<input checked="" type="radio"/>	<input type="radio"/>	<input checked="" type="radio"/>	<input type="radio"/>	<input type="radio"/>	<input type="radio"/>	<input type="radio"/>	<input type="radio"/>	<input type="radio"/>	<input type="radio"/>	<input type="radio"/>	<input type="radio"/>	<input type="radio"/>	<input type="radio"/>	<input type="radio"/>	<input type="radio"/>	<input type="radio"/>
BuzziTrom		<input checked="" type="radio"/>	<input type="radio"/>	<input type="radio"/>	<input type="radio"/>	<input type="radio"/>	<input type="radio"/>	<input type="radio"/>	<input type="radio"/>	<input type="radio"/>	<input type="radio"/>	<input type="radio"/>	<input type="radio"/>	<input type="radio"/>	<input type="radio"/>	<input type="radio"/>	<input type="radio"/>	<input type="radio"/>
BuzziZepp Light	LED Line	<input checked="" type="radio"/>	<input type="radio"/>	<input type="radio"/>	<input type="radio"/>	<input type="radio"/>	<input type="radio"/>	<input type="radio"/>	<input type="radio"/>	<input type="radio"/>	<input type="radio"/>	<input type="radio"/>	<input type="radio"/>	<input type="radio"/>	<input type="radio"/>	<input type="radio"/>	<input type="radio"/>	<input type="radio"/>

WOOD

ASH BLACK STAINED
ASH WHITE WASH
OAK
WALNUT
ASH NATURAL
ASH WALNUT STAINED
CUMARU
IROKO
ANTWERP OAK
ASH LACQUERED
HPL
WHITE LAMINATE

Ash Black Stained



Properties Black clear coating with a matt look, consisting of a durable finish, suitable for furniture, that masks normal wear and leaves the wood grain visible to the eye.
Maintenance First, wipe the surface with a dry cloth then clean carefully with a damp cloth. Do not use any abrasive cleaning products or scourers as this can damage the surface.

Ash White Wash



Properties Oil based coating with white pigments consisting of durable finish, suitable for furniture, that masks normal wear and leaves the wood grain visible to the eye.
Maintenance First, wipe the surface with a dry cloth then clean carefully with a damp cloth. Do not use any abrasive cleaning products or scourers as this can damage the surface.

Oak



Properties Clear coating with a matt varnish look, consisting of a durable finish, suitable for furniture, that masks normal wear and leaves the wood grain visible to the eye.
Maintenance First, wipe the surface with a dry cloth then clean carefully with a damp cloth. Do not use any abrasive cleaning products or scourers as this can damage the surface.

Walnut

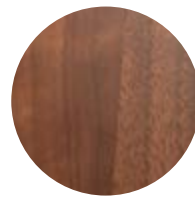

Properties Clear coating with a matt varnish look, consisting of a durable finish, suitable for furniture, that masks normal wear and leaves the wood grain visible to the eye.
Maintenance First, wipe the surface with a dry cloth then clean carefully with a damp cloth. Do not use any abrasive cleaning products or scourers as this can damage the surface.

Ash Natural



Properties Clear coating with a matt varnish look, consisting of a durable finish, suitable for furniture, that masks normal wear and leaves the wood grain visible to the eye.
Maintenance First, wipe the surface with a dry cloth then clean carefully with a damp cloth. Do not use any abrasive cleaning products or scourers as this can damage the surface.

Ash Walnut Stained



Properties Oil based coating with walnut colored pigments consisting of durable finish, suitable for furniture, that masks normal wear and leaves the wood grain visible to the eye.
Maintenance First, wipe the surface with a dry cloth then clean carefully with a damp cloth. Do not use any abrasive cleaning products or scourers as this can damage the surface.

Note color deviation may occur.
Find the latest update of the material specifications and colors on our website: www.buzzi.space
Refinishing In the event that scratching or marring has occurred we recommend that refinishing be carried out by a professional furniture refinishing company.

Cumaru



Properties Tropical hardwood which is more resistant to weather influences. No oil or varnish is applied. In normal use, wood will turn grey over time.
Maintenance Aftermarket teak cleaning product can be used for yearly maintenance to freshen up the wood after winter. Do not use any abrasive cleaning product or scourers as this can damage the wood. Cumaru wood is naturally durable but may be prone to movement and cracking in outdoor environments.

Iroko



Properties Tropical hardwood which is more resistant to weather influences. Oil based coating with white pigments consisting of durable finish, suitable for furniture, that masks normal wear and leaves the wood grain visible to the eye.
Maintenance First, wipe the surface with a dry cloth then clean carefully with a damp cloth. Do not use any abrasive cleaning products or scourers as this can damage the surface. Note: Iroko wood is naturally durable but may be prone to movement and cracking in outdoor environments.

Antwerp Oak



Properties Oak Solid wood with a subtle rustic look, allowing some pith and small cracks. Oil based coating with white pigments consisting of durable finish, suitable for furniture, that masks normal wear and leaves the wood grain visible to the eye.
Maintenance First, wipe the surface with a dry cloth then clean carefully with a damp cloth. Do not use any abrasive cleaning products or scourers as this can damage the surface.

Ash Lacquered

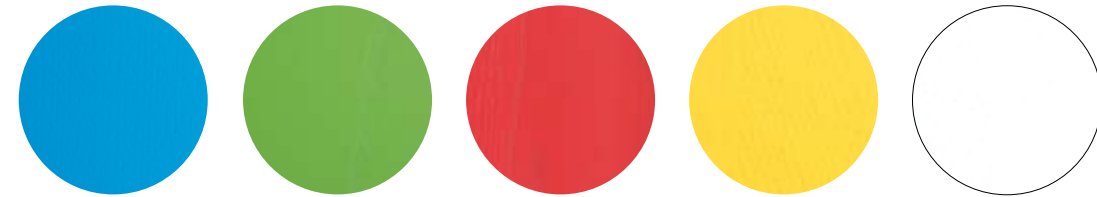

Blue
PANTONE 299 C

Green
PANTONE 370 C

Red
PANTONE 185 C

Yellow
PANTONE 115 C

White
PANTONE 000 C

Properties Lacquered coating with matt look, leaving a visual woodgrain.

Maintenance First clear the surface with a dry cloth, then clean with a slightly damp cloth. Do not use abrasive cleaning products nor scourers, they can damage the surface.

HPL



Volcanic Black
Duropl U 12000 W

Truffle Grey
Duropl U 16000 W

Pearl
Duropl U 11026 W

WOOD

ASH BLACK STAINED
ASH WHITE WASH
OAK
WALNUT
ASH NATURAL
ASH WALNUT STAINED
CUMARU
IROKO
ANTWERP OAK
ASH LACQUERED
HPL
WHITE LAMINATE

WOOD

Ash Black Stained
 Ash White Wash
 OAK
 WALNUT
 ASH NATURAL
 ASH WALNUT STAINED
 Cumaru
 Iroko
 Antwerp Oak
 Ash Lacquered
 HPL
 WHITE LAMINATE

White Laminate

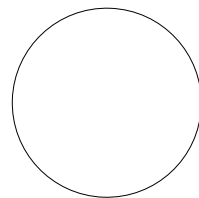

Properties HPL top layer with plywood core and straight oiled visible plywood edge

Maintenance Depending on the stains/dirt there are different prescriptions:

LIGHT: dry or damp paper towels, a cloth or sponge.

NORMAL: with a cloth or soft nylon brush and washing powder, soft soap, toilet soap or washing-up liquid. If necessary, leave for a while and then rinse thoroughly with clean water.

HEAVY: Discoloration stains through long exposure to tea, coffee, etc. use washing powder and household bleach (but do not repeat too often). For stains such as lead pencil, felt-tip pens, marker and ball-point pens use an organic solvent for example acetone (nail varnish remover).

Powder Coated Metal

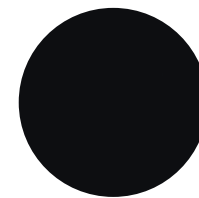

Black
RAL 9005

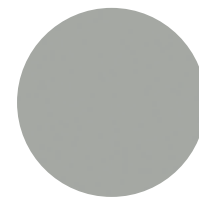

Alu
RAL 9006

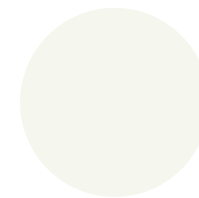

White
RAL 9010

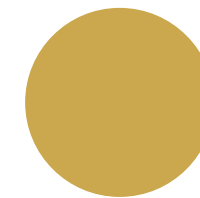

Gold

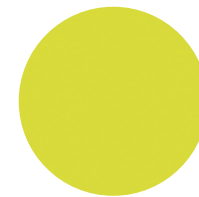

Fluo Yellow
RAL 1016

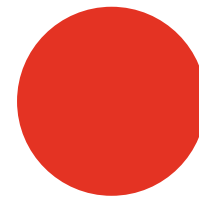

Fluo Orange
RAL 2005

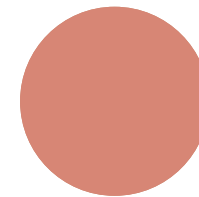

Beige Red
RAL 3012

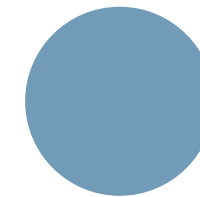

Pastel Blue
RAL 5024

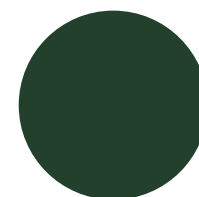

Black Green
RAL 6012

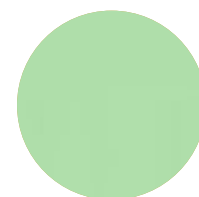

Pastel Green
RAL 6019

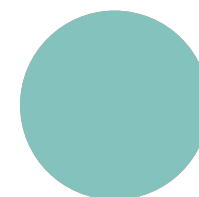

Light Green
RAL 6027

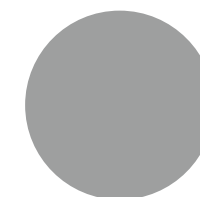

Signal Grey
RAL 7004

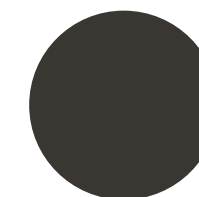

Umbra Grey
RAL 7022

Properties Fine-textured powder coated steel or aluminum with a matt look.

Maintenance Clean as needed using a soft cloth or brush with a mild detergent. Avoid steam cleaning, abrasive cleansers, carbon steel brushes/wools and cleaners containing chlorine.

Uncoated Aluminum

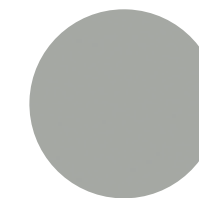

Properties Bare aluminum with clear coating.

Maintenance Clean as needed using a soft cloth or brush with a mild detergent. Avoid steam cleaning, abrasive cleansers, carbon steel brushes/wools and cleaners containing chlorine.

Galvanized Steel

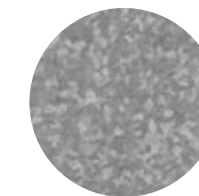

Properties Hot-Dip Galvanization > applying a protective coating layer to prevent corrosion of the metal part.

Maintenance Clean as needed using a soft cloth or brush with a mild detergent. Avoid steam cleaning, abrasive cleansers, carbon steel brushes/wools and cleaners containing chlorine.

Note color deviation may occur.
 Find the latest update of the material specifications and colors on our website: www.buzzi.space

Refinishing Renovation should be done by a specialist in furniture coating. It requires sanding of the parts and re-applying an equal amount of coating on all sides.

Note color deviation may occur.
 Find the latest update of the material specifications and colors on our website: www.buzzi.space

Refinishing Renovation should be done by a specialist in furniture coating. It requires sanding of the parts and re-applying an equal amount of coating on all sides.

METAL

POWDER COATED METAL
 UNCOATED ALUMINUM
 GALVANIZED METAL

NO BOUNDARIES

BuzziSpace
Catalog 2020-2021

NO BOUNDARIES

INDEX

STORIES 004

About BuzziSpace	004 - 007
Local Manufacturing	008 - 011
Meet our Designers	012 - 021
Silence is Not a Luxury	022 - 025

PRODUCT CATEGORIES 027

Acoustic Solutions	028 - 157
Acoustic Furniture	158 - 227
Furniture	228 - 271
Lighting	272 - 319
Outdoor	320 - 327
Materials	328 - 391

INDEX 394**CONTACT 397****PRODUCTS**

BuzziBack	32
BuzziBalance	162
BuzziBell	274
BuzziBlinds	37
BuzziBlinds Classic	34
BuzziBlox	41
BuzziBoard	47
BuzziBooth	173
BuzziBounce	230
BuzziBox	233
BuzziBox Travel	235
BuzziBracks	167
BuzziBreeze	323
BuzziBrickBack	49
BuzziBrickBack Architectural	50
BuzziCactus	52
BuzziCane	236
BuzziChandelier	276
BuzziCone	278
BuzziCube 3D	178
BuzziCube Flat	176
BuzziDee	180
BuzziDesk	55
BuzziDesk Cross	59
BuzziDesk FlipFlop	60
BuzziDesk Split	63
BuzziDish	64
BuzziDome	280
BuzziDonut	66
BuzziFalls	71
BuzziFalls Standing	75
BuzziFloat	239
BuzziFree	79
BuzziFrio	81
BuzziFrontDesk	82

BuzziGrid	85
BuzziGrip	86
BuzziHat	284
BuzziHive	185
BuzziHood	187
BuzziHub	189
BuzziHub Table	243
BuzziHug	190
BuzziJet	289
BuzziJet Standing	292
BuzziJungle	245
BuzziKey Soft	89
BuzziLand	91
BuzziLight Mono	294
BuzziLoose	92
BuzziMe	193
BuzziMilk	246
BuzziMilk Table	251
BuzziMirage	253
BuzziMood	94
BuzziMoon	297
BuzziNest	197
BuzziNordic ST100	254
BuzziNordic ST400	257
BuzziNordic ST900	324
BuzziPicNic	258
BuzziPicNic Round	264
BuzziPlank	267
BuzziPlant	97
BuzziPlanter	98
BuzziPleat	102
BuzziPleat Light	300
BuzziPouf	205
BuzziProp	304
BuzziPuzzle	207
BuzziRing	208

BuzziScreen	106
BuzziScreen Mix	108
BuzziShade	306
BuzziShade Square	310
BuzziShade Standing	312
BuzziShed	327
BuzziShield Desk	111
BuzziShield Free	114
BuzziShield Hook	116
BuzziSkin	120
BuzziSkin Cuts	123
BuzziSkin Printed	124
BuzziSol	314
BuzziSpark	210
BuzziSpot	217
BuzziSuzzi	269
BuzziTable	270
BuzziTab Soft	126
BuzziTemp	219
BuzziTile 3D	130
BuzziTile Flat	128
BuzziTotem	135
BuzziTripl Desk	140
BuzziTripl Desk Split	142
BuzziTripl Home	144
BuzziTripl Wrap Desk	146
BuzziTrom	316
BuzziTwist	149
BuzziVille	220
BuzziWings	150
BuzziWrap Desk	152
BuzziWrap FrontDesk	154
BuzziZepp	156
BuzziZepp Light	318

PUBLISHER

RESPONSIBLE EDITOR

BuzziSpace
Groeningenlei 141
BE-2550 Antwerp - Kontich
Marketing Department

EDITORIAL

Nathalie Blancquaert
Eva Deruelle
Astrid de Chaffoy
Dada Goldberg
Cathrine Jensen
Els Kerckhof
Stijn Melis
Romina Rico
Katrien Van Lysebeth
Gerrie Van Rijzingen
Ellen Van Steen
Sarah Van Vlierberghe
Daniel Verlooven

CONCEPT

Nathalie Blancquaert
Peter Michiels
Sim Ruts
Ellen Van Steen
Sven Verbeeck
Henk Willems

PHOTOGRAPHY

Andrea Bartoluccio
Peter Bennetts
Jessica Boutsen
Chris Bradley
Studio#pointu by Philip Braem
BuzziSpace Studio
Bob Coscarelli
Siegfried Demyttenaere
Cathérine Duval
Jens Ellensohn
Liam Frederick
Ben Gancsos
King George
Dada Goldberg
Amit Goshier
Toon Grobet
Leon Hargreaves
Kristina Hrabětová
Andrea Janssen
Philipp Jester
Tom Kurek
Grey Limited
Andrea Liverani
Bryan Regan Photography
Jasper Sanidad
Bernard Schramm
Olivier Strobbe
Christine Strub
Karsten Thormaehlen
Steve Tsai
Alexandre Van Battel
Simon Van Ranst
Frederic Verduyssen
Jean-Mark Wullschleger

CONTACT

BuzziSpace HQ

Groeningenlei 141
2550 Antwerp - Kontich
Belgium
info@buzzi.space
+32 3 846 10 00

Office | Manufacturing The Netherlands

Industrieweg 7a
5531 AD Bladel
The Netherlands
manufacture@buzzi.space
+31 497 387 478

Office USA

1200 Redding Drive
High Point, NC 27260
USA
us@buzzi.space
+1 336 821 3150

Sh'Office Chicago

222 Merchandise Mart Plaza Suite 10-111
Chicago, IL 60651
USA
us@buzzi.space
+1 336 821 3150

Sh'Office New York

45 West 21st Street - 3rd floor
NY 10010
USA
us@buzzi.space
+1 336 821 3150

